

# John Dee

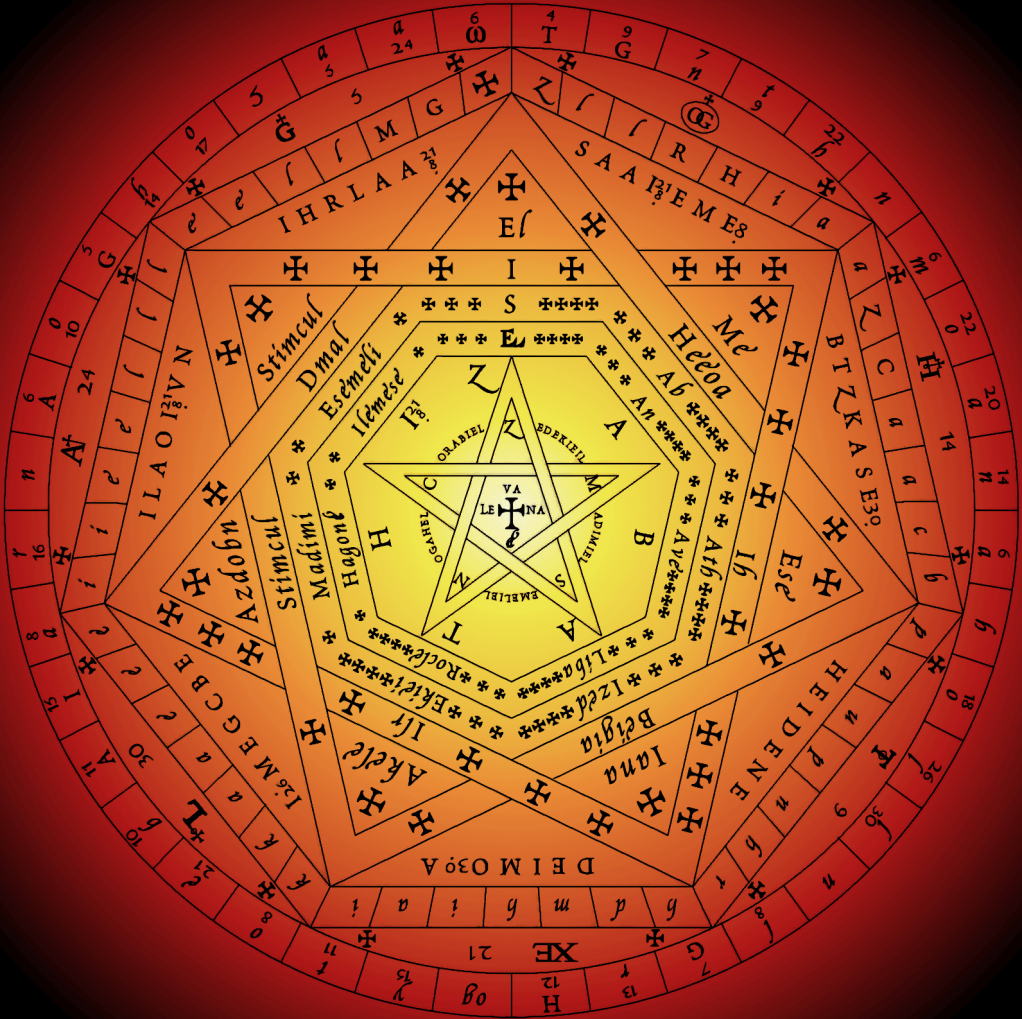

# Collected Works



The Collected Works of

JOHN DEE



HERITAGE



## Index

|                                      |     |
|--------------------------------------|-----|
| The Hieroglyphic Monad.....          | 1   |
| Compendium Heptarchiae Mysticae..... | 49  |
| Mysteriorum Liber Primus.....        | 87  |
| Mysteriorum Liber Secundus.....      | 109 |
| Mysteriorum Liber Tertius.....       | 139 |
| The Rosie Crucian Secrets.....       | 165 |
| The Enochian Calls or Keys.....      | 299 |
| Tuba Veneris.....                    | 311 |



The  
Hieroglyphic  
Monad

John Dee, London,

to

MAXIMILIAN,  
by God's Grace  
Most Wise Emperor  
of  
Rome, Bohemia, and Hungary



## THEOREM I

It is by the straight line and the circle that the first and most simple example and representation of all things may be demonstrated, whether such things be either non-existent or merely hidden under Nature's veils.

## THEOREM II

Neither the circle without the line, nor the line without the point, can be artificially produced. It is, therefore, by virtue of the point and the Monad that all things commence to emerge in principle. That which is affected at the periphery, however large it may be, cannot in any way lack the support of the central point.



## THEOREM III

Therefore, the central point which we see in the centre of the hieroglyphic Monad produces the Earth, round which the Sun, the Moon, and the other planets follow their respective paths. The Sun has the supreme dignity, and we represent him by a circle having a visible centre.

## The Hieroglyphic Monad

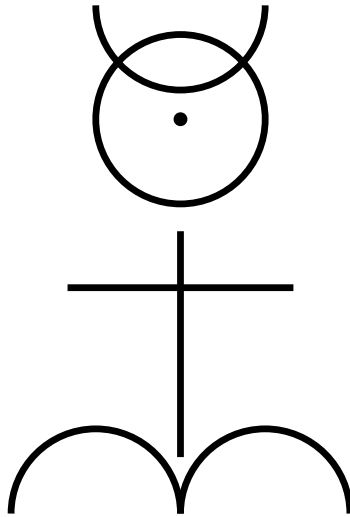

### THEOREM IV

Although the semicircle of the Moon is placed above the circle of the Sun and would appear to be superior, nevertheless we know that the Sun is ruler and King. We see that the Moon in her shape and her proximity rivals the Sun with her grandeur, which is apparent to ordinary men, yet the face, or a semi-sphere of the Moon, always reflects the light of the Sun. It desires so much to be impregnated with solar rays and to be transformed into Sun that at times it disappears completely from the skies and some days after reappears, and we have represented her by the figure of the Horns (Cornucopia).

### THEOREM V

And truly I give the completion of the idea of the solar circle by adding a semicircle for the Moon, for the morning and the evening were the first day, and it

was therefore in the first (day) that the Light of the Philosophers was made (or produced).

### THEOREM VI

We see here that the Sun and the Moon are supported upon the right-angled Cross. This Cross may signify very profoundly, and for sufficient reasons in our hieroglyph, either the Ternary or the Quaternary. The Ternary is made by the two straight lines having a copulative centre.

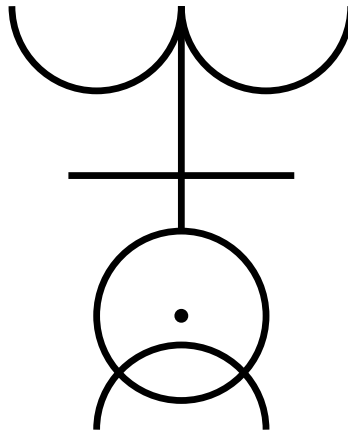

The Quaternary is produced by the four straight lines enclosing four right angles. Either of these elements, the lines or the right angles, repeated twice, therefore, afford us in the most secret manner the Octad, which I do not believe was known to our predecessors, the Magi, and which you should study with great attention. The threefold magic of the first Fathers and the wise men consisted in Body, Soul and Spirit. Therefore, we have here the first manifested Septenary, that is to say, two straight lines with a common point which make three, and the four lines which converge to form the central point in separating the first two.

## THEOREM VII

The Elements being far from their accustomed places, the homogeneous parts are dislocated, and this a man learns by experiment, for it is along the straight lines that they return naturally and effectively to these same places. Therefore, it will not be absurd to represent the mystery of the four Elements, in which it is possible to resolve each one into elementary form, by four straight lines running in four contrary directions from one common and indivisible point. Here you will notice particularly that the geometricians teach that a line is produced by the displacement of a point: we give notice that it must be the same here, and for a similar reason, because our elementary lines are produced by a continual cascade of droplets as a flux in the mechanism of our magic.

## THEOREM VIII

Besides, the kabbalistic extension of the Quaternary according to the common formula of notation (because we say one, two, three, and four) is an abridged or reduced form of the Decad. This is because Pythagoras was in the habit of saying:  $1+2+3+4$  make 10. It is not by chance that the right-angled Cross—that is to say, the twenty-first letter of the Roman alphabet, which was considered as being formed by four straight lines, was taken by the most ancient of the Roman Philosophers to represent the Decad.

Further, they have defined the place where the Ternary conducts its force into the Septenary.

## THEOREM IX

We see that all this accords perfectly with the Sun and Moon of our Monad, because, by the magic of the four Elements, an exact separation upon their original lines must be made; following which the circulatory conjunction within the solar complement through the peripheries of these same lines is performed, because however long a given line may be, it is possible to describe a circle passing through its extremes, following the laws of the geometricians. Therefore, we cannot deny how useful the Sun and the Moon are to our Monad, in conjunction with the decadal proportion of the Cross.

## THEOREM X

The following figure of the zodiacal sign Aries, in use amongst the astronomers, is the same for all the world (a sort of erection both cutting and pointed), and it is understood that it indicates the origin of the fiery triplicity in that part of the sky. Therefore, we have added the astronomical sign Aries to signify that in the practice of this Monad the use of fire is required.



We finish the brief hieroglyphic consideration of our Monad, which we would sum up in one only hieroglyphic context:

The Sun and the Moon of this Monad desire that the Elements in which the tenth proportion will

flower, shall be separated, and this is done by the application of Fire.

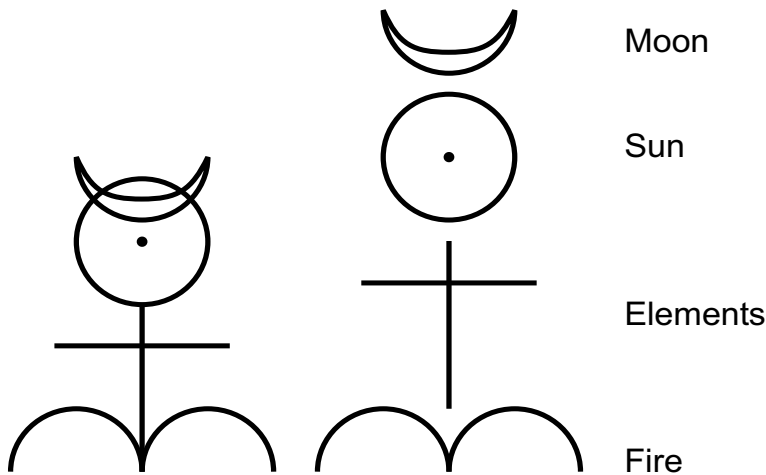

### THEOREM XI

The mystical sign of the Ram, composed of two semicircles connected by one common point, is very justly attributed to the place of the equinoctial nycthemeron, because the period of twenty-four hours divided by means of the equinox denotes most secret proportions.

This I have said in respect of the Earth.

### THEOREM XII

The very ancient wise men and Magi have transmitted to us five hieroglyphical signs of the planets, all of which are composed out of the signs used for the Moon and the Sun, together with the sign of the Elements and the hieroglyphical sign of Aries, the Ram, which will become apparent to those who examine these figures:

Each one of these signs will not be difficult to explain according to the hieroglyphical manner in

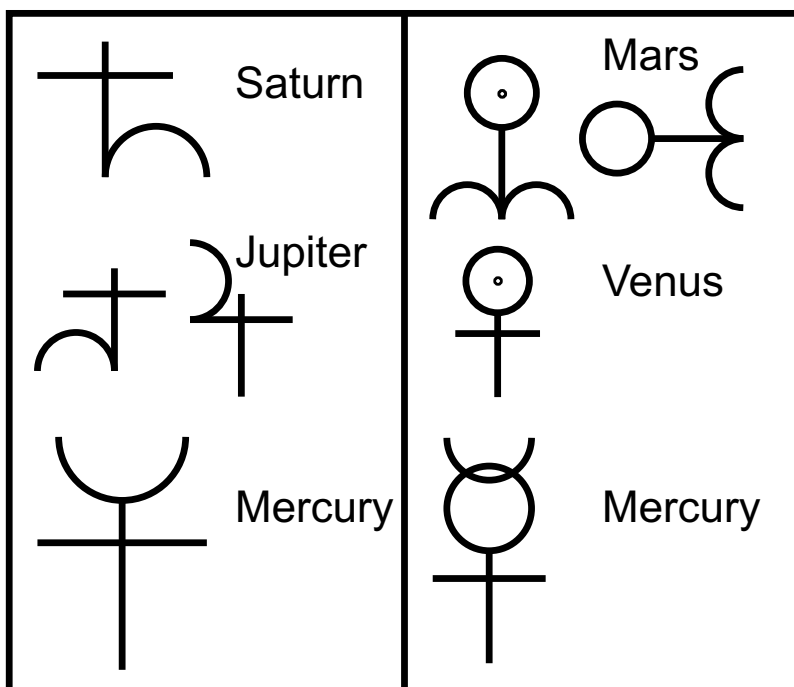

view of our fundamental principles, already posited. To begin with, we will speak in paraphrases of those which possess the characteristics of the Moon: following that, of those which possess a solar character. When our lunar nature, by the science of the Elements, had accomplished the first revolution round our Earth, then it was called, mystically, Saturn. Afterwards, at the following revolution, it was named

Jupiter, and holds a very secret figure. Then the Moon, developed by yet a third journey, was represented very obscurely again by this figure which it was their custom to call Mercury. You see how this is Lunar. That it must be conducted through a fourth revolution will not be contrary to our most secret design,

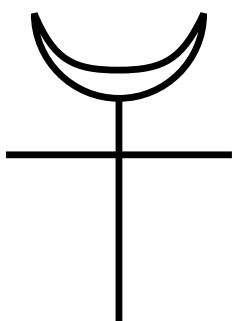

whatever certain sages may say. In this manner the pure magical spirit, by its spiritual virtue, will perform the work of the albification at the place of the Moon; to us alone and as it were in the middle of a natural day he will speak hieroglyphically without words, introducing and imprinting these four geogonic figures in the pure Earth very simply prepared by us:

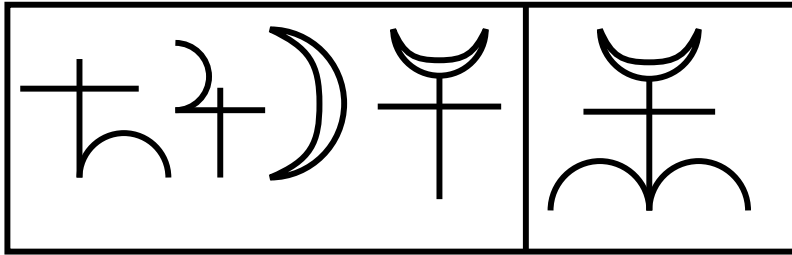

this last figure being in the middle of all the others.

### THEOREM XIII

Now regard the mystical character of Mars! Is it not formed from the hieroglyphs of the Sun and Aries, the magistry of the Elements partly intervening? And that of Venus - I wish to know is it not produced from that of the Sun and the Elements according to the best exponents? Therefore, the planets look towards the solar periphery and the work of revivification.

In the progression we will notice this other Mercury will appear who is truly the twin brother of the first: for by the complete Lunar and Solar magic of the Elements, the Hieroglyph of this Messenger speaks to us very distinctly, and we should examine it carefully and listen to what it says. And (by the Will of God) it is

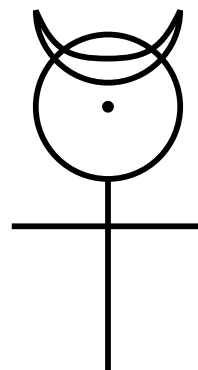

the Mercury of the Philosophers, the greatly celebrated microcosm and ADAM. Therefore, some of the most expert were inclined to place him in a position of, and give him a rank equal to, the Sun himself. This we cannot perform in the present epoch unless we add to this coraline crystal work a certain SOUL separated from the body by the pyrognomic art. It is very difficult to accomplish this and very perilous because of the fire and the sulphur which the breath contains within it. But certainly this Soul can perform marvellous things. For example, join it by indissoluble ties to the disc of the Moon (or at least of Mercury) by Lucifer and Fire. In the third place, it is necessary that we should show (in order to demonstrate our Septenary number) that it is the Sun of Philosophers itself. You will observe the exactitude as well as the clarity with which this anatomy of our Hieroglyphic Monad corresponds to what is signified in the arcana of these two theorems.

#### THEOREM XIV

It is therefore clearly confirmed that the whole magistry depends upon the Sun and the Moon. Thrice Greatest Hermes has repeatedly told us this in affirming that the Sun is its father and the Moon is its mother: and we know truly that the red earth (terra lemnia) is nourished by the rays of the Moon and the Sun which exercise a singular influence upon it.

#### THEOREM XV

We suggest, therefore, that Philosophers should consider the action of the Sun and the Moon upon the Earth. They will notice that when the light of the Sun

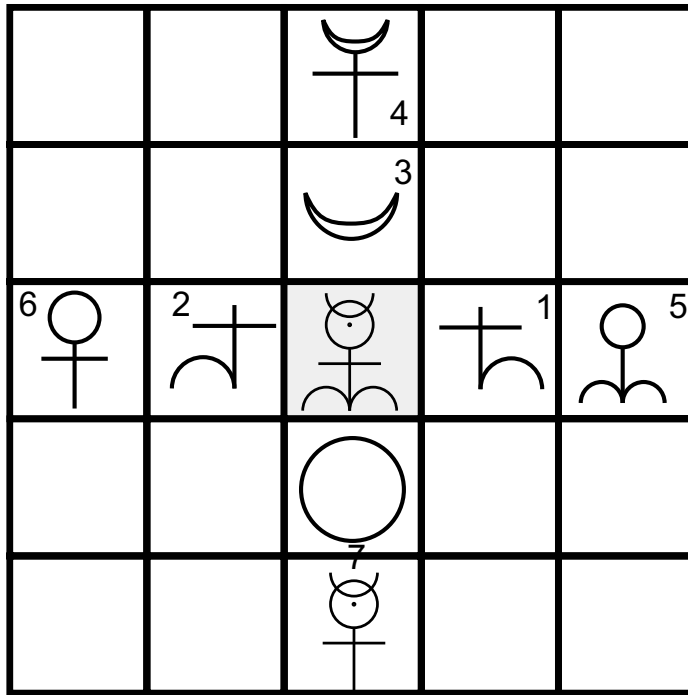

The Principles of the Inferior Astronomy, shown in the Anatomy of our Monad.

enters Aries, then the Moon, when she enters the next sign, that is to say Taurus, receives a new dignity in the light and is exalted in that sign in respect of her natural virtues. The Ancients explained this proximity of the luminaries – the most remarkable of all – by a certain mystic sign under the name of the Bull. It is very certain that it is this exaltation of the Moon to which in their treatises the astronomers from the most ancient times bear witness. This mystery can be understood only by those who have become the Absolute Pontiffs of the Mysteries. For the same reason they have said that Taurus is the house of Venus – that is to say, of conjugal love, chaste and prolific, for

nature rejoices in nature, as the great Ostones concealed in his most secret mysteries. These exaltations are acquired by the Sun, because he himself, after having undergone many eclipses of his light, received the force of Mars, and is said to be exalted in this same house of Mars which is our Ram (Aries).

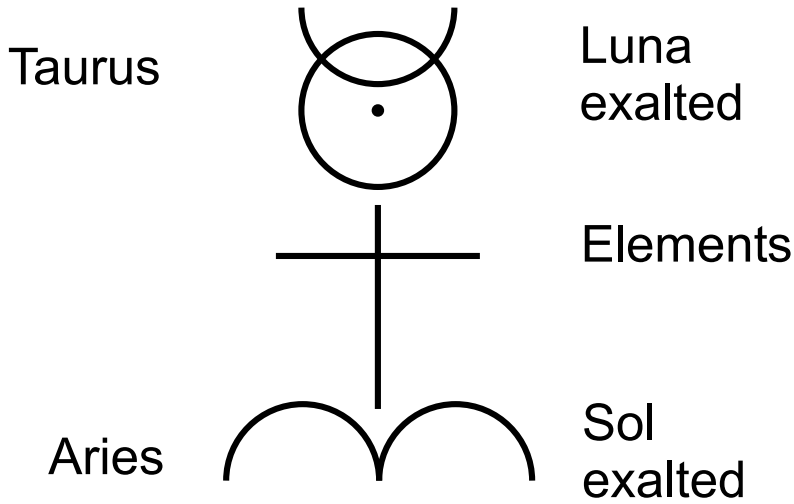

This most secret mystery is clearly and perfectly shown in our Monad by the hieroglyphic figure of Taurus, which is here represented, and by that of Mars, which we have indicated in Theorem XII and Theorem XIII by the Sun joined to a straight line towards the sign of Aries.

In this theory another kabbalistic analysis of our Monad offers itself, because the true and ingenious explanation is this: the exaltations of the Moon and of the Sun are made by means of the science of the Elements.

Note. – There are two things which should be particularly observed: first, that the hieroglyphic figure of Taurus is the same as the diphthong of the Greeks, which was always used in terminating the singular

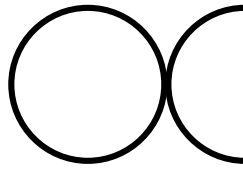

gender; secondly, that by a simple transposition of place we show the letter alpha twice, by a circle and a half-circle, being simply tangents which touch one another as shown.

### THEOREM XVI

We must now, in view of our subject, philosophise for a short time upon the Cross. Our Cross may be formed of two straight lines (as we have said) which are equal one to the other – that is to say, we cannot separate the lines except we do it by parting them so that we get equal lengths. But in the mystic distribution of the components of our Cross, we wish to use parts which are both equal and unequal. These parts show that a virtue is hidden under the power of the division of the Equilateral Cross into two parts, because they are of equal grandeur. In general, the Cross must be composed of equal right angles, since the nature of justice demands the perfect equality of the lines used in the decussation. In accordance with this justice, we propose to examine with care that which follows concerning the Equilateral Cross (which is the twenty-first letter of the Latin alphabet).

If, through the common point where the opposite angles meet in our Rectilineal, Rectangular, and Equilateral Cross, we imagine a straight line dividing it into two parts, then on either side of the line thus traversed we find the parts are perfectly equal and similar.

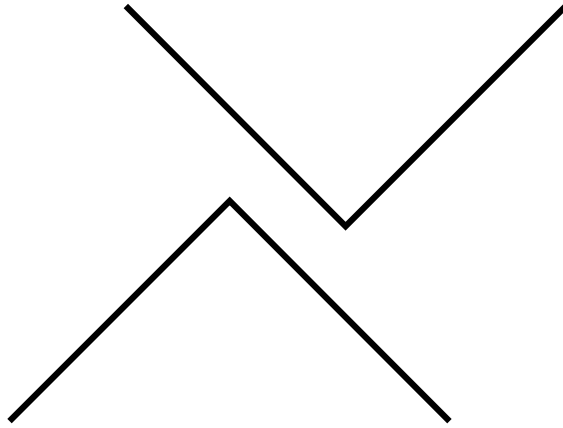

And these parts are similar in shape to that letter of the Romans which is regarded as the fifth of the vowels, and which was frequently used by the most ancient Latin Philosophers to represent the number five. This, I conceive, was not done by them without good reason, because it is in fact the exact half of our Decad. Of these parts of the figure thus duplicated by the hypothetical division of the Cross, we must conclude it to be reasonable that each part represents the quinary, although one is upright and the other reversed in imitation of the multiplication of the square root which comes in here in a marvellous way as the circular number, that is to say, the quinary, from which we find the number twenty-five is produced (because this letter is the twentieth of the alphabet and the fifth of the vowels).

We will now consider another aspect of this same Equilateral Cross – that which follows is based upon the position shown in our Monadic Cross. Let us suppose a similar division of the Cross into two parts be made as in the drawing. Now we see the germinating shape of another letter of the Latin alphabet – the one

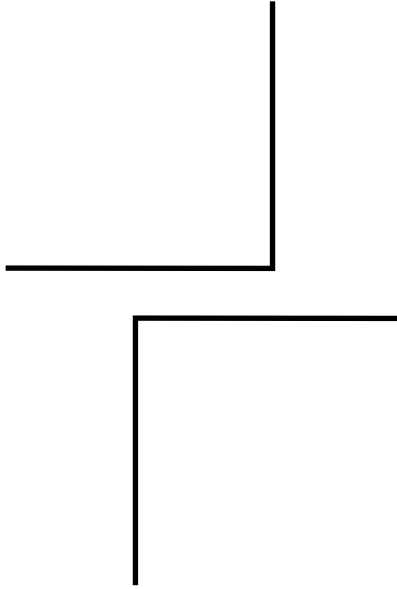

upright, the other reversed and opposite. This letter is used (after the ancient custom of the Latins) to represent the number fifty. From this, it seems to me, we establish our Decad of the Cross, for this is placed at the summit of all the mysteries, and it follows that this Cross is the hieroglyphic sign of perfection. Therefore, enclosed within the quinary force is the power of the Decad, out of which comes the number fifty as its own product.

Oh, my God, how profound are these mysteries! and the name EL is given to this letter! And for this very reason, we see that it responds to the decadal virtue of the Cross, because, starting from the first letter of the alphabet, L is the tenth letter, and counting backwards from the letter X, we find that it falls into the tenth place, and since we show that there are two parts of the Cross, and considering now their numerical virtue, it is quite clear how the number one hundred is produced. And if by the law of squares these

two parts be multiplied together, they give a product of 2500. This square compared with the square of the first circular number, and applied to it, gives a difference of one hundred, which is the Cross itself explained by the square of its Decad, and is recognised as one hundred. Therefore, as this is contained within the figure of the Cross, it also represents unity. By the study of these theories of the Cross, the most dignified of all, we are thereby induced to utilise this progression, viz. one-ten-one hundred, and this is the decadal proportion of the Cross as it appears to us.

### THEOREM XVII

After a due study of the sixth theorem it is logical to proceed to a consideration of the four right angles in our Cross, to each one of which, as we have shown in the preceding theorem, we attribute the significance of the quinary according to the first position in which they are placed, and in transposing them to a new position, the same theorem shows that they become hieroglyphic signs of the number fifty. It is quite evident that the Cross is vulgarly used to indicate the number ten, and further, it is the twenty-first letter, following the order of the Latin alphabet, and it is for this reason that the sages amongst the Mecubales designated the number twenty-one by this same letter. In fact, we can give a very simple consideration to this sign to find out what other qualitative and quantitative virtues it possesses. From all these facts we see that we may safely conclude, by the best kabbalistic computation, that our Cross, by a marvellous metamorphosis, may signify for the Initiates two hundred and fifty-two. Thus: four times five, four times fifty, ten,

twenty-one and one, which added together make two hundred and fifty-two. We can extract this number by two other methods as we have already shown: we recommend to the Kabbalists who have not yet made experiments to produce it, not only to study it in its conciseness, but also to form a judgment worthy of philosophers in regard to the various permutations and ingenious productions which arise from the magistry of this number. And I will not hide from you a further memorable mystagogy: consider that our Cross, containing so many ideas, conceals two further letters if we examine carefully their numerical virtues after a certain manner, so that, by a parallel method following their verbal force with this same Cross, we recognise with supreme admiration that it is from here that LIGHT is derived (LUX), the final word of the magistry, by the union and conjunction of the Ternary within the unity of the Word.

### THEOREM XVIII

From our Theorems XII and XIII it may be inferred that celestial astronomy is the source and guide of the inferior astronomy. Before we raise our eyes to heaven, kabbalistically illuminated by the contemplation of these mysteries, we should perceive very exactly the construction of our Monad as it is shown to us not only in the LIGHT but also in life and nature, for it discloses explicitly, by its inner movement, the most secret mysteries of this physical analysis. We have contemplated the heavenly and divine functions of this celestial Messenger, and we now apply this co-ordination to the figure of the egg. It is well known that all astrologers teach that the form of

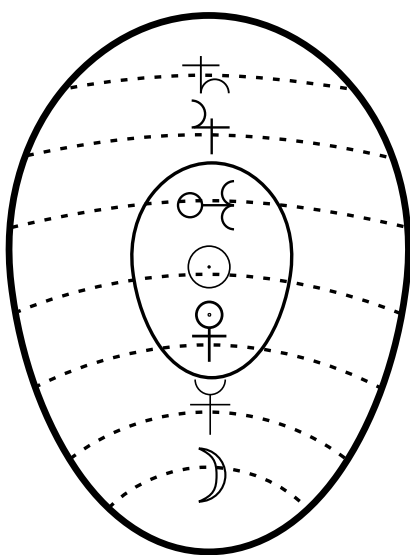

the orbit traversed by a planet is circular, and because the wise should understand by a hint, it is thus that we interpret it in the hieroglyph, shown, which conforms in every detail with all that has gone before. Here you will note that the miserable alchemists must learn to recognise their numerous errors and to understand what is the water of the white of egg, what is the oil of the yoke of egg, and what we mean by calcined egg-shells. These inexpert impostors must learn in their despair to understand what are meant by these and many other similar expressions. Here we have shown almost all the proportions which correspond to Nature herself. This is the same Eagle's Egg which the scarab formerly broke because of the injury which the cruelty and violence of this bird caused to timid and primitive man, for this bird pursued some of them who were running to the cavern where the scarab dwelt, to implore his aid. The scarab wondered in what manner he alone could revenge such insolence,

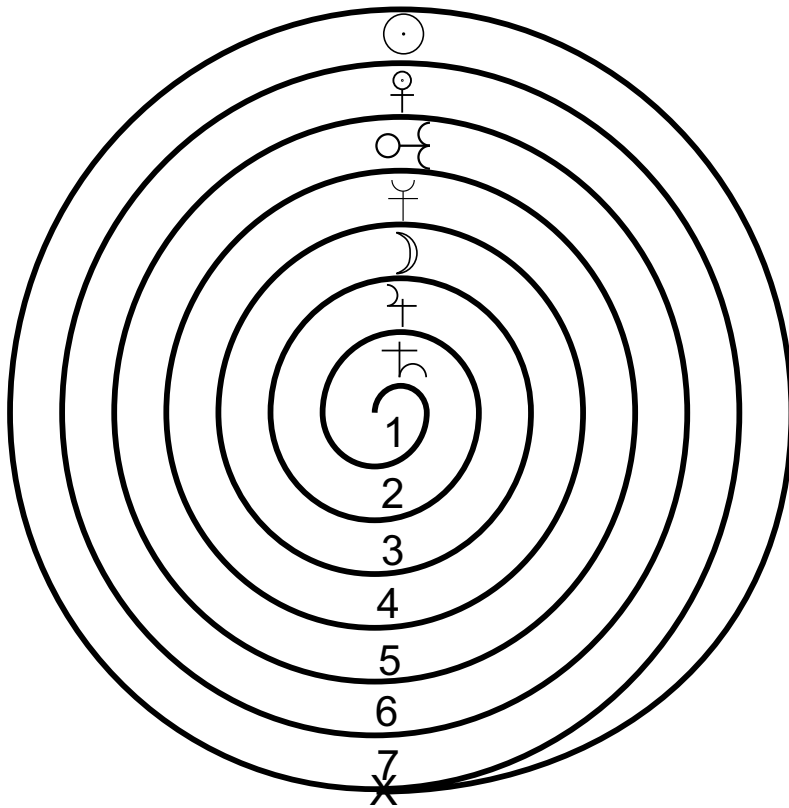

and, being of an ardent character, prepared to accomplish his purpose by constancy and determination, for he was short of neither power nor intelligence. The scarab pursued the eagle resolutely and made use of this very subtle trick: he let fall his ordure in the bosom of Jupiter where the egg was deposited, with the result that the God in getting rid of it threw the egg to the ground, where it was broken. The scarab by this method would have completely exterminated the whole family of eagles from the Earth had not Jupiter, in order to avoid such a calamity, resolved that, during that part of the year when the eagles watch over their eggs, no scarab should come flying near them. There-

fore, I counsel those who are ill-treated by the cruelty of this bird, that they learn the very useful art from these solar insects (*Heliocantharis*) who live concealed and hidden for very long periods of time. By these indications and signs, for which they should be very thankful, they themselves will be able to take vengeance on their enemy. And I affirm (O King!) that it is not Aesop but Oedipus who prompts me, for he presented these things to worthy souls, and ventured for the first time to speak of these supreme mysteries of Nature. I know perfectly well that there have been certain men who, by the art of the scarab, have dissolved the eagle's egg and its shell with pure albumen and have formed thereby a mixture of all; afterwards they have reduced this mixture to a yellow liquid, by a notable process, viz. by a ceaseless circulation just as the scarabs roll their balls of earth. By this means the great metamorphosis of the egg was accomplished; the albumen was absorbed during a great many revolutions round the heliocentric orbits, and was enveloped in this same yellow liquid. The hieroglyphic figure shown here, of this art, will not displease those who are familiar with Nature.

We read that during the early centuries, this art was much celebrated amongst the most serious and ancient Philosophers, as being certain and useful. Anaxagoras performed the magistry and extracted therefrom an excellent medicine, as you may read in his book.

He who devotes himself sincerely to these mysteries will see clearly that nothing is able to exist without the virtue of our hieroglyphic Monad.

## THEOREM XIX

The Sun and the Moon shed their corporeal forces upon the bodies of the inferior Elements, much more so than all the other planets. It is this fact which shows, in effect, that in the pyrognomic analysis all metals lose the aqueous humour of the Moon as well as the igneous liquor of the Sun, by which all corporeal, terrestrial, and mortal things are sustained.

## THEOREM XX

We have shown sufficiently that for very good reasons the Elements are represented in our Hieroglyph by the straight lines, therefore we give a very exact speculation concerning the point which we place in the centre of our Cross. This point cannot by any means be abstracted from our Ternary. Should anyone who is ignorant of this divine learning, say that in this position of our Binary the point can be absent, we reply, he may suppose it to be absent, but that which remains without it will certainly not be our Binary; for the Quaternary is immediately manifested, because by removing the point we discontinue the unity of the lines. Now, our adversary may suppose that by this argument we have reconstructed our Binary; that in fact our Binary and our Quaternary are one and the same thing, according to this consideration, which is manifestly impossible. The point must of necessity be present, because with the Binary it constitutes our Ternary, and there is nothing that can be substituted in its place. Meanwhile he cannot divide the hypostatic property of our Binary without nullifying an integral part of it. Thus it is demonstrated that it must

not be divided. All the parts of a line are lines. This is a point, and this confirms our hypothesis. Therefore, the point does not form part of our Binary and yet it forms part of the integral form of the Binary. It follows that we must take notice of all that is hidden within this hypostatic form and understand that there is nothing superfluous in the linear dimension of our Binary. But because we see that these dimensions are common to both lines, they are considered to receive a certain secret image from this Binary. By this we demonstrate here that the Quaternary is concealed within the Ternary. O God, pardon me if I have sinned against Thy Majesty in revealing such a great mystery in my writings which all may read, but I believe that only those who are truly worthy will understand.

We therefore continue to expound the Quaternary of our Cross as we have indicated. Seek diligently to discover whether the point may be removed from the position in which we first find it. The mathematicians teach that it may be displaced quite simply. At the moment when it is separated the Quaternary remains, and it becomes much more clear and distinct to the eyes of all.

This is not a part of its substantial proportions, but only the confused and superfluous point which is rejected and removed.

O Omnipotent Divine Majesty, how we Mortals are constrained to confess what great Wisdom and what ineffable mysteries reside in the Law which Thou hast made! Through all these points and these letters the most sublime secrets, and terrestrial arcane mysteries, as well as the multiple revelations of this unique point, now placed in the Light and examined

by me, can be faithfully demonstrated and explained. This point is not superfluous within the Divine Trinity, yet when considered, on the other hand, within the Kingdom of the four Elements it is black, therefore corruptible and watery. O thrice and four times happy, the man who attains this (almost copulative) point in the Ternary, and rejects and removes that sombre and superfluous part of the Quaternary, the source of vague shadows. Thus after some effort we obtain the white vestments brilliant as the snow.

Oh, Maximilian, May God, through this mystagogy, make you or some other scion of the House of Austria the most powerful of all when the time comes for me to remain tranquil in Christ, in order that the honour of His redoubtable name may be restored within the abominable and intolerable shadows hovering above the Earth. And now for fear that I myself should say too much I shall immediately return to the burden of my task, and because I have already terminated my discourse for those whose gaze is centred within the heart, it is now necessary to translate my words for those whose heart is centred within their eyes. Here, therefore, we can represent in some measure in the figure of the Cross that which we have already said. Two equal lines are equally and inequally crossed through the point of necessity which you see in A. The four straight lines, as in B, produce a sort of vacuum where they are withdrawn from the central point, which was their common condition, in which state they were not prejudicial, the one to the other. This is the path by which our Monad, progressing through the Binary and the Ternary into the purified Quaternary, is reconstituted within itself, united in

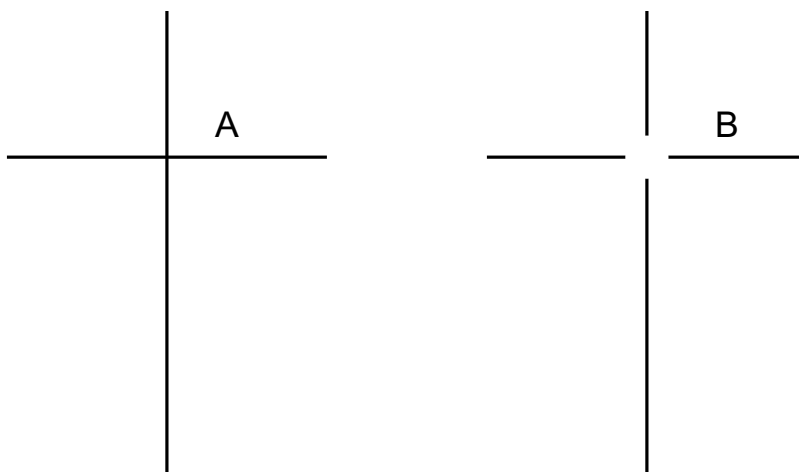

equal proportions, and which now shows that the whole is equal to its combined parts, for during the time that this takes place our Monad will not admit of other units or numbers, because it is self-sufficient, and exactly so, within itself; absolute in all numbers in the amplitude of which it is diffused, not only magically but also by a somewhat vulgar process employed by the artist, which produces great results in dignity and power within this selfsame Monad, which is resolved into its own first matter; whilst that which is foreign to its nature and to its natural hereditary proportions is segregated with the greatest care and diligence and rejected for ever amongst the impurities.

## THEOREM XXI

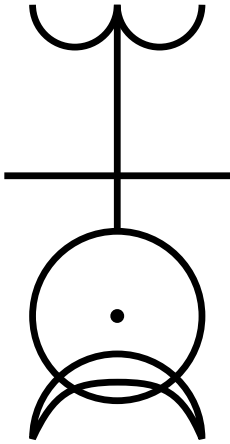

If that which is hidden within the profundities of our Monad be brought to light, or, on the contrary, if those primary parts which are exterior in our Monad are enclosed in the centre, you will see the extent to which the philosophical transformation can be produced. We will now expound to you another local commutation of our mystical Monad, using those parts from the hieroglyphic characters of the superior planets which are immediately

offered to us. Each one of the other planets for this purpose is in turn elevated to a position which was frequently assigned to them by Plato, therefore, if they are conveniently taken in this position and at this point in Aries, Saturn and Jupiter are in conjunction. By descending, the Cross represents Venus and Mercury, followed by the Sun himself with the Moon at the bottom. This will be refuted in other circles; meantime, as we have no wish to hide the philosophical treasure of our Monad, we have taken a resolution to give a reason by which the position of the Monad is by this manner displaced. Yet see! listen to these other great secrets which I know and will disclose to assist you as touching this position, which I can explain in few words. We distribute our Monad, now looked at from a different aspect, and analysed in a different manner, as is seen at B, D, C. In this new Ternary the

figures C and D are known to all men, but the figure designated B is not easy of comprehension.

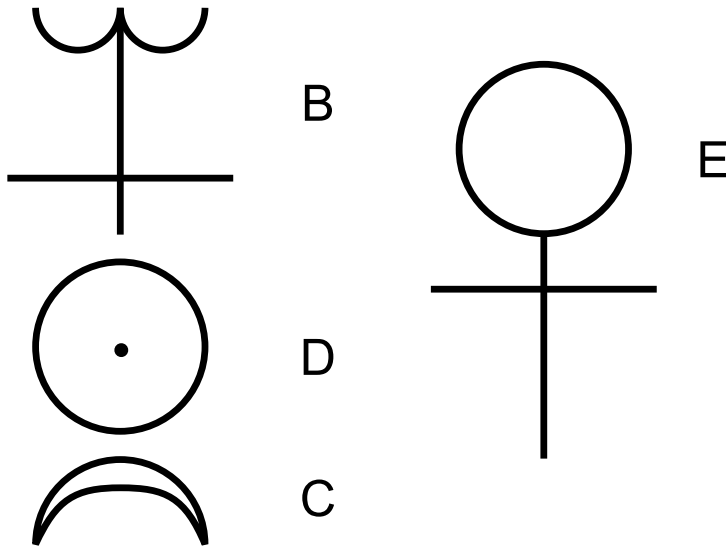

It is necessary to give careful consideration to the known forms D and C, which show that the essences are separated and distinct from the figure B: also we see that the Horns of the figure C are turned downwards towards the Earth. That part of D which illumines C is also towards the Earth, that is to say, downwards, in the centre of which the solitary visible point alone is truly the Earth: finally these two figures D and C turned towards the lower end give a hieroglyphic indication of the Earth. Therefore, the Earth is made to represent, hieroglyphically, stability and fixation. I leave you to judge from this what is meant by C and D: from which you may take notice of a great secret. All the qualities which we have in the first place ascribed to the Sun and the Moon can here be given a perfect and very necessary interpretation, these two stars up to now having been placed in the superior

position with the horns of the Moon raised on high; but we have already spoken of this.

We will now examine, according to the fundamentals of our hieroglyphic Art, the nature of this third figure B. First, we carry to the Crown the double crescent of the Moon which is our Aries, turned round in a mystical manner. Then follows the hieroglyphic sign of the Elements, which is attached to it. As to why we use the double Moon, it may be explained that it is according to the matter, which requires a double quantity of the Moon. We speak of those grades of which in their experiments the Philosophers could find no more than four, amongst all created substances, that is to say, to be, to live, to feel and to comprehend (*esse, vivere, sentire et intelligere*). In saying that the first two of these Elements are found here, we say that they are called *argent vive (luna existens, viva)*, all life being subject to movement, there being six principles of movement. The Cross which is attached implies that in this artifice the Elements are requisite. We have told you many times that in our theory the hieroglyph of the Moon is like a semicircle, and on the contrary the complete circle signifies the Sun, whereas here we have two semicircles separated, but touching at a common point; if these are combined, as they can be by a certain art, the product can represent the circular plenitude of the Sun. From all those things which we have considered, the result is that we can summarise, and in hieroglyphic form, offer the following:

*Argent vive*, which must be developed by the magistry of the Elements, possesses the power of the solar force through the unification of its two semicircles combined by a secret art.

The circle, of which we have spoken and which we designate in the figure by the letter E, is thus accomplished and formed. You will recollect, we have said that the solar degree is not delivered to us ready to our hand by Nature, but that it is artificial and not produced by Nature, it being available to us in its first aspect in accordance with its proper nature (as in B) in two parts separated and dissolved, and not solidly united in the solar body. In fact, the semi-diameter of these half-circles is not equal to the semi-diameter of D and C, but much smaller. Everyone can see this from the manner in which we have drawn them in the diagram, from which it is clear that this same B has not as great an amplitude as D and C. The proportions in the figure confirm this, being by this means transformed into a circle from B into E. Therefore, there appears before our eyes the sign of Venus alone. We have already demonstrated by these hieroglyphical syllogisms that from B we cannot obtain the true D, and that the true C is not and cannot be completely within the nature of B; therefore, this of itself is not able to become the true "Argent Vive." You may already doubt the subject of this life and of this movement, whether it is possible, in fact, to possess it naturally or not. However, as we have already explained to the wise, all those things which are said about B, in a similar manner will be at least analogical, and all that which we have briefly taught concerning C and D can be very well applied, by analogy, to this same B accompanied by its Elements.

Indeed, that which we have attached to the nature of Aries, should exactly fit the case, because it carries this figure B, although reversed, at its summit, and

that which is attached to the figure B, is the mystical figure of the Elements. Therefore, we see by this anatomy that from the body of our Monad alone, separated in this manner by our Art, this new Ternary is formed.

This we cannot doubt, for the reason that the members which composed it reassemble and form amongst themselves of their own free will a monadic union and sympathy which is absolute. By this means we discover amongst these members a force which is both magnetic and active.

Finally I think it well to note here, by way of recreation, that this same B shows very clearly the same proportions in the malformed and rustic letter in that it carries visible points towards the top and at the front and that these letters are three in number, otherwise they number six, summarising three times three: they are crude and malformed, unstable and inconstant, made in such a manner as to appear formed of a series of half-circles. But the method of making these letters more stable and firm is in the hands of the literary experts. I have here placed before your eyes an infinitude of mysteries: I introduce a game but to interrupt a theory. Meanwhile I do not understand the efforts of certain people who rise up against me. Our Monad being reconstituted in its first mystical position and each one of its parts being ordered by Art, I advise and exhort them to search with zeal for that fire of Aries in the first triplicity, which is our equinoctial fire and which is the cause whereby our Sun may be elevated above his vulgar quality. Many other excellent things should also be studied in happy and wise meditations.

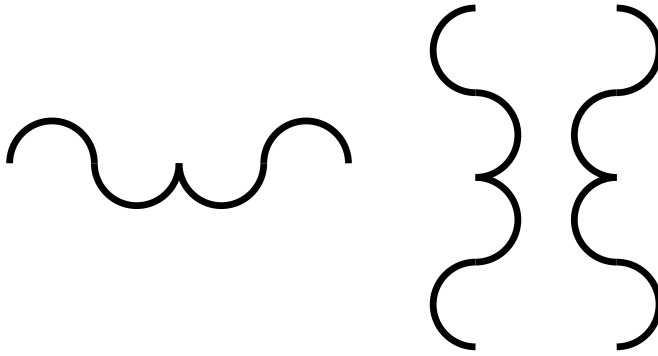

We now pass on to another subject; we wish to point the way, not only in a friendly but also in a faithful manner, to those other secrets upon which we must insist, before we lapse into silence and which, as we have said, comprise a most remarkable infinitude of other mysteries.

### THEOREM XXII

It will be readily understood that the mysteries of our Monad cannot be extracted unless one is drawn towards the pharmacy of this same Monad, and that these mysteries must not be revealed to any but the Initiates. I offer here for the contemplation of your Serene Highness, the vessels of the Sacred Art which are truly and completely kabbalistic. All those lines which unite the diverse parts of our Monad are most wisely separated; we give to each one of them a special letter, in order to distinguish them one from another as you will see in the diagram.

We inform you that in  $\alpha$  is found a certain artificial vessel, formed of A and B with the line M. The exterior diameter is common to both A and B, and this is not different, as we see, from this the first letter of the

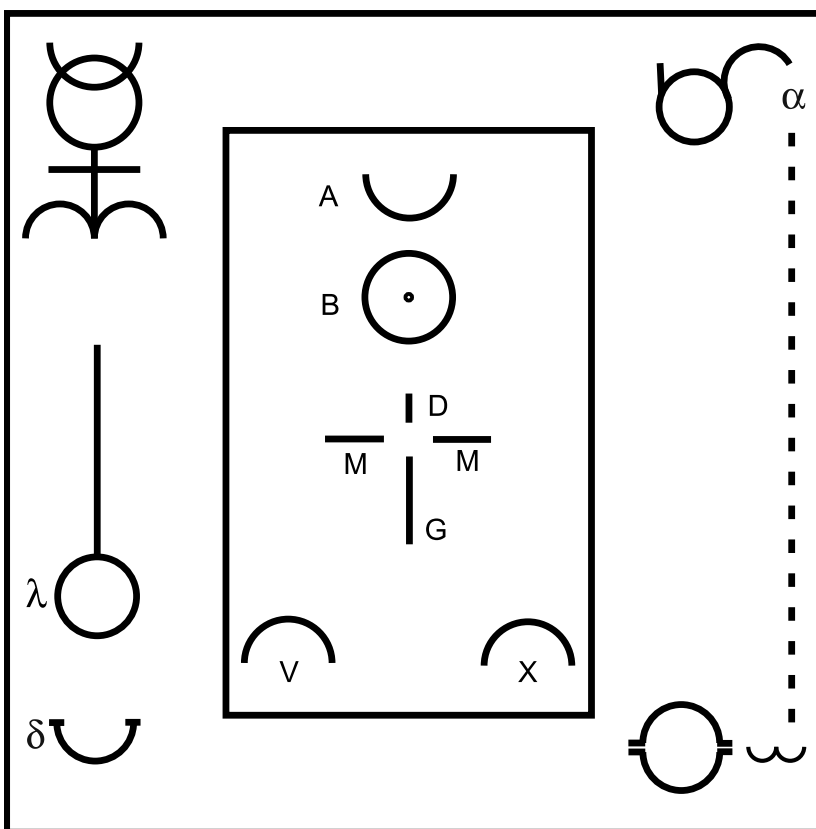

Greek alphabet, except by a single transposition of the parts.

We teach the true mystical sympathy first by the line, the circle, and the semicircle, and, as we have formerly said, this symmetry can only be formed of the circle and the semicircle, which are always joined for the same mystical purpose.

It follows that  $\lambda$  and  $\delta$  are in themselves the shapes of other vessels. That is to say,  $\lambda$  is made of glass and  $\delta$  of earth (earthenware or clay). In the second place,  $\lambda$  and  $\delta$  may remind us of the Pestle and Mortar, which must be made of suitable substance, in which artificial unperforated pearls, lamels of crystal and beryl,

chrysolite, precious rubies, carbuncles and other rare artificial stones may be ground to powder.

Lastly, that which is indicated by the letter  $\omega$  is a small vessel containing the mysteries, which is never far from this last letter of the Greek alphabet now restored to its primitive mystagogy, and which is made by a single transposition of its component parts, consisting of two half-circles of equal size. Concerning the vulgar objects and necessities which are required in addition to the vessels, and the materials out of which they should be fashioned, it would be useless that we should treat of it here. Meanwhile a must be considered as if searching for the occasion to perform its function by a very secret and rapid spiral circulation and an incorruptible salt by which the first principle of all things is preserved, or better, that the substance which floats within the vitriol after its dissolution, shows the apprentice a primordial but very transitory specimen of our work, and if he is attentive, a very subtle and most effective way to prepare the work will be revealed to him.

Within  $\lambda$ , the glass vessel, during the exercise of its particular function, all air must be excluded or it will be extremely prejudicial. The corollary of  $\omega$  is the agreeable man, ready, active, and well disposed at all times. Who, then, is not now able to procure the sweet and salutary fruits of this Science, which, I say, spring from the mystery of these two letters?

Some of those who would draw us away from our Garden of the Hesperides, and would make us view this a little closer as in a mirror, say that it is established that it is not formed from anything but our Monad.

But the straight line which appears in Alpha is homologous with that which, in the separation of the final analysis of our Cross, is already designated by the letter M. One may discover by these means from where the others are produced. See the scheme outlined in the table on page 33.

In these few words, I know that I give not only the principles but the demonstration to those who can see in them how to fortify the igneous vigour and the celestial origin, so that they may lend a willing ear to the great Democritus, certain that it is not mythical dogma but mystic and secret, according to which it is the medicine of the soul, the liberator from all suffering, and is prepared for those who wish for it and as he has taught; it is to be sought for in the Voice of the Creator of the Universe, so that men, inspired by God, and engendered anew, learn through the perfect disquisition of the mystical languages.

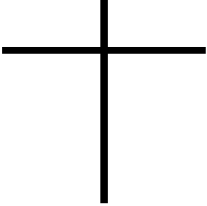
|   |   |  |
|---|---|--|
|  |  |  |
| Existing before the Elements  | The Elements (Chaos)  | After the Formation of the Elements  |
| Mortal Adam, male & female  | Consummation of the Genealogy of Elements   | Immortal Adam  |
| The Mortifying Self   | CROSS   | The Vivifying Self   |
| Wrapped in Shadows  | CROSS   | Manifestation  |
| Born in a stable  | Sacrificed on the Cross   | King of All ubiquitous   |
| Self-conceived by own influence   | Death and Burial  | Reborn from its own Virtue   |
| Power in the Seed   | IHVH Decadal Virtue   | Triumph in Glory   |
| Creation of HYLE  | Purification of the Elements  | Transformation   |
| Earthly Marriage  | Martyrdom on the CROSS  | Divine Marriage  |
| Beginning   | Middle  | End  |

## THEOREM XXIII

We now present in diagrammatic form the proportions already observed by us in the hieroglyphic construction of our Monad, which must be observed by those who wish to engrave them upon their seals or their rings, or to utilise them in some other manner. In the name of Jesus Christ crucified upon the Cross, I say the Spirit writes these things rapidly through me; I hope, and I believe, I am merely the quill which traces these characters. The Spirit draws us now towards our Cross of the Elements, with all the following measures which are also to be obtained by a reasoning process according to the subject-matter which it is proposed to discuss. Everything which exists under the heaven of the Moon contains the principle of its own generation within itself and is formed from the coagulation of the four Elements, unless it be the primary substance itself, and this in several ways not known to the vulgar, there being nothing in the created world in which the Elements are in equal proportion or in equal force. But by means of our Art, they can be restored to equality in certain respects, as the wise well know; therefore, in our Cross, we make the parts equal and unequal.

Another reason is that we can proclaim either similitude, or diversity, or unity, or plurality in affirming the secret properties of the equilateral Cross, as we have said before.

If we were to expound all the reasons which we know, for the proportions established in this way, or if we were to demonstrate the causes by another method which we have not done, although we have done so

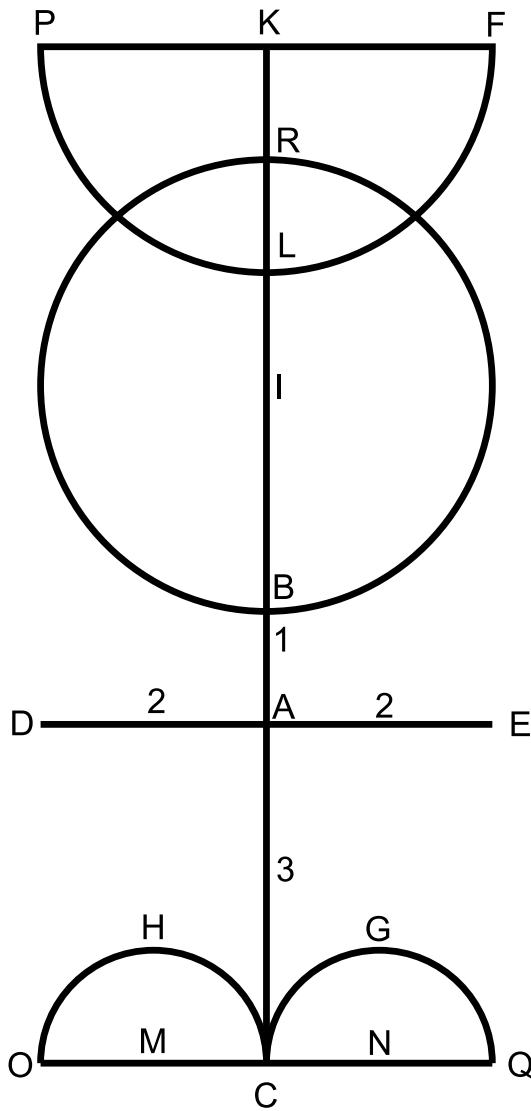

sufficiently for the Sages, we should transcend the limits of obscurity which we have prescribed, not without reason, for our discourse.

Take any point, as *A* for example, draw a straight line through it in both directions, as *CAK*. Divide the line *CK* at *A* by a line at right angles, which we will call *DAE*. Now select a point anywhere on the line

AK, let it be B, and one obtains the primary measurement of AB, which will be the common measure of our work. Take three times the length of AB and mark off the central line from A to C, which will be AC. Now take twice the distance between AB and mark it off on the line DAE at E and again at D, in such a way that the distance between D and E is four times the distance between A and B. Thus is formed our Cross of four Elements, that is to say, the Quaternary formed by the lines AB, AC, AD, AE. Now on the line BK take a distance equal to AD up the central line to I. With this point I as a centre, and IB as the radius, describe a circle which cuts the line AK at R: from the point R towards K mark a distance equal to AB, let it be RK. From the point K draw a line at right angles to the central line on both sides, forming an angle on either side of AK, which will be PFK. From the point K measure in the direction of F a distance equal to AD, which will be KF: now with K as centre and KF as radius describe a half-circle FLP, so that FKP is the diameter. Finally, at point C draw a line at right angles to AC sufficiently long in both directions to form OCQ. Now on the line CO we measure from C a distance equal to AB, which is CM, and with M as a centre and MC as a radius we describe a semicircle CHO. And in the same manner on CQ, from the point C we measure a distance equal to AB which is CN, and from the centre N, with CN as radius, we trace a semicircle CGQ, of which CNQ is the diameter. We now affirm, from this, that all the requisite measurements are found explained and described in our Monad.

It would be well to notice, you who know the distances of our mechanism, that the whole of the line CK is composed of nine parts, of which one is our fundamental, and which in another fashion is able to contribute towards the perfection of our work: then, again, all the diameters and semi-diameters must be designated here by suppositional lines hidden or obscured, as the geometricians say. It is not necessary to leave any centre visible, the exception being the solar centre, which is here marked by the letter I, to which it is unnecessary to add any letter. Meanwhile those who are adept at our mechanism can add something to the solar periphery, by way of ornament and not by virtue of any mystical necessity: for this reason it has not been formerly considered by us. This something is a boundary ring, necessarily a line parallel to the original periphery. The distance between these parallels may be fixed at a quarter or a fifth part of the distance AB. One may also give to the crescent of the Moon a form which this planet frequently assumes in the sky, after her conjunction with the Sun—that is to say, in the form of the Horns, which you will obtain if from the point K in the direction of R you measure the distance just mentioned, i.e. the fourth or fifth part of the line AB, and if from the point thereby obtained, as a centre, you trace with the original lunar radius the second part of the lunar crescent, which joins the extremities at both ends of the first semicircle. You may perform a similar operation in respect of the positions M and N when erecting the perpendicular at each one of these centre points; we can use the sixth part of AB or a little less, from which point, as the

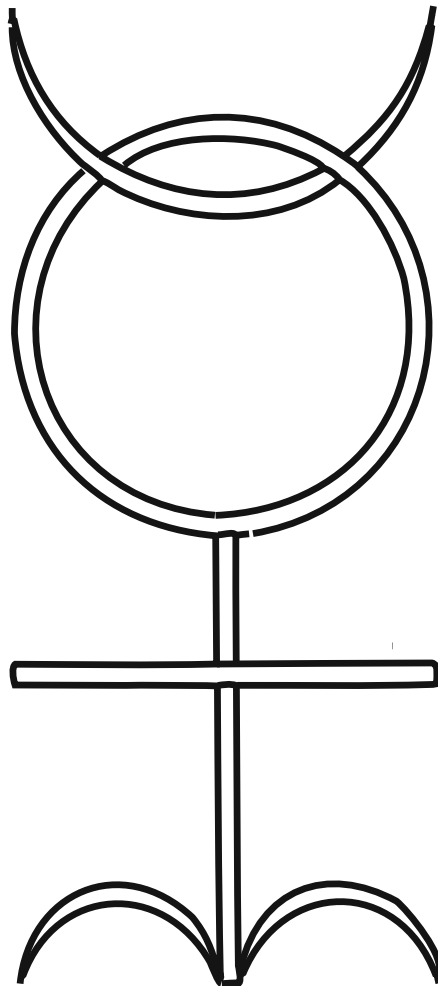

centre, we describe two other semicircles, using the radius of the two first, MC and NC.

Lastly, the parallels may be traced at each side of the two lines of our Cross, each side at a distance from the centre line of one-eighth to one-tenth part of the distance AB, in such a way that our Cross be in this manner formed into four superficial lines where the width is the fourth or the fifth part of this same line AB.

I have wished in some way to sketch these ornaments in the figure which each one may reproduce according to his own fancy. It is a condition, however, that you do not commit any fault, however small, against the mystical symmetry for fear of introducing by your negligence a new discipline into these hieroglyphic measurements; for it is very necessary that during the succeeding progression in time they must be neither disturbed nor destroyed. This is much more profound than we are able to indicate, even if we wished to do so, in this small book, for we teach Truth, the daughter of Time, God willing.

We will now expound methodically certain things which you may find on your way by practising the proportions of our Monad. Then we will show by many examples the existence of four lines corresponding to the four lines of our Cross, and which in this consideration we are not able simply to announce, because of the proportions and the particular and mystical results which are produced in another fashion, from the Quaternary of these same lines. And thirdly, we will show that there exist within Nature certain useful functions determined by God by means of numbers, which we have happily obtained and which are explained either in this theorem, or in others, contained in this little book.

Finally, we will insert other things in an opportune place which, if they are conveniently understood, will produce fruits most abundantly.

We now abruptly conclude.

## Our Canon of Transposition (Metathesis)

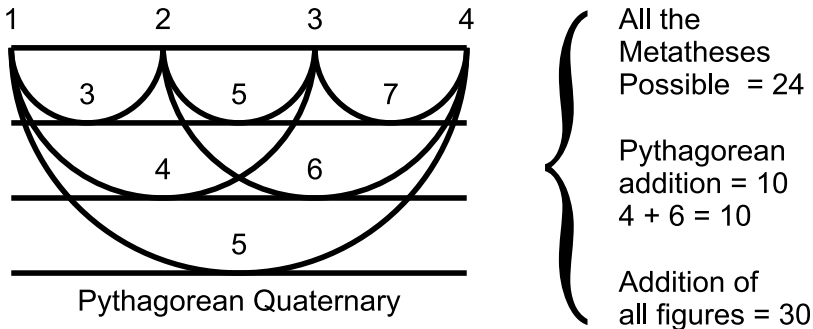

Take the same proportion which is shown in numbers when written in the natural order, after the first Monad, then from the first to the last make a continuous multiplication – that is to say, the first by the second, the product of these two by the third, and this product by the fourth, and so on until the last; the final product determines all the Metatheses possible, in respect of the proportion in space, and for the same reason in proportion to diverse objects as you wish.

I tell thee, O King, this operation will be useful unto thee in many circumstances, whether in the study of Nature or in the affairs of the government of men; for it is that which I am accustomed to use with the greatest of pleasure in the Tziruph or Themura of the Hebrews.

I know that many other powerful numbers may be produced out of our Quaternary, by virtue of arithmetic and the power of numbers. Yet he who does not understand that a very great obscurity has by this method been illuminated by those numbers which I have drawn out which have nature and distinction

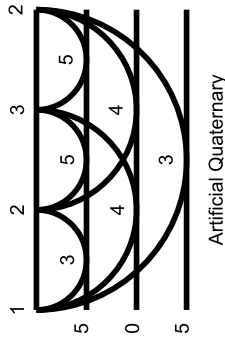

The continuous multiplication gives 12

Simple addition gives  $\left\{ \begin{matrix} 8 \\ 7 \end{matrix} \right\} \left\{ \begin{matrix} 1 \\ 4 \end{matrix} \right\} \left\{ \begin{matrix} 4 \\ 3 \end{matrix} \right\}$

The sum of all numbers

24

equal to every possible Metathesis of the Quaternary. It determines the physical purity and the sovereign excellence of the Gold of 24 Carats considered from the point of view of Physical Existence on Earth.

Our Numbers possess such dignity that to violate their Laws is a Sin against the wisdom of nature. They can teach us the greatest Mysteries, & we must examine them both as units & in their proportions to find their mutual combinations.

which are

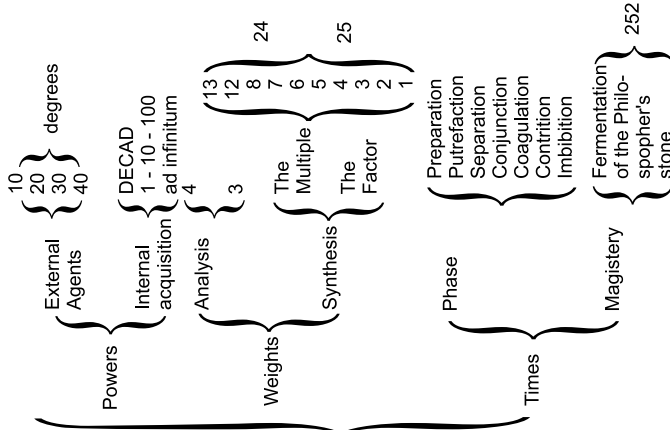

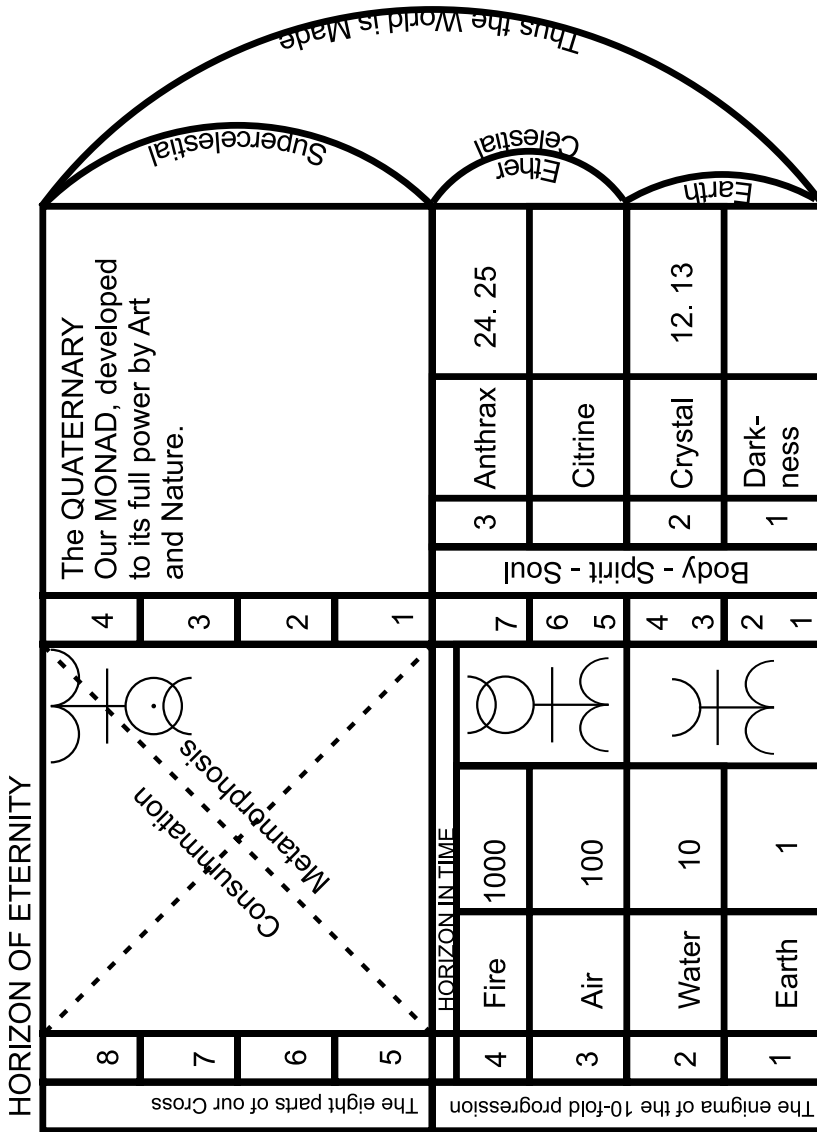

amongst such a multitude, will not be able to estimate their meaning, which is obscure and not to the point. How many will find in our numbers the authority which we have promised for the weight of the Elements; for the statements regarding measurements of time; and for the certainty of proportions which may

be assigned to the powers and forces of things ? All this you should study in the two preceding diagrams.

Many things may be deduced from the diagrams which, it is preferable, should be studied silently rather than divulged openly in words. Meantime, let us inform you of one thing, amongst many others, disclosed now for the first time by us, in respect of this new Art; to wit, we have here established a rational cause by virtue of which the Quaternary with the Decad, in a certain manner, terminate the numerical series. We affirm that this cause is not exactly that which was described by the Masters who have preceded us, but just as we have stated it here. This Monad has been integrally and physically restored to itself – that is to say, it is truly the Monad Unitissima,

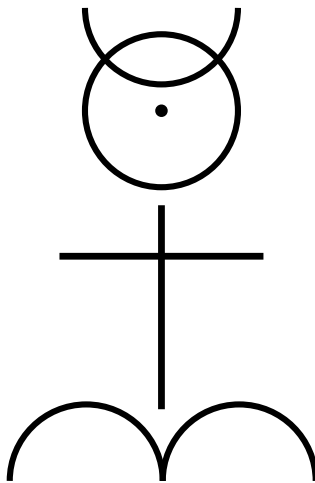

the proved unity of the images; and it is not within the power of Nature, neither can we by any art promote in it any movement or any progression whatsoever, unless it be by four super-celestial cycles or revolutions, and from this Monad is engendered that which we wish to note as the manner and course of its eminence; and for this reason, that there is not in the elemental world,

nor in the celestial or super-celestial worlds, any created power or influence which cannot be absolutely favoured and enriched by it.

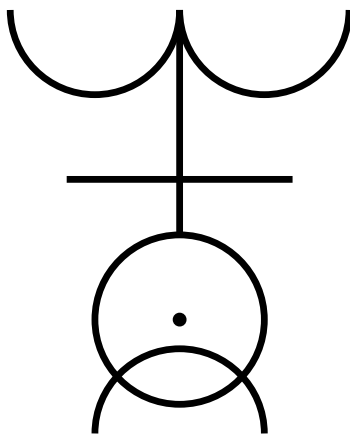

It was because of the true effect of this that four illustrious men, friends of Philosophy, were upon an occasion together in the great work. One day they were astonished by a great miracle in this thing, and forthwith dedicated themselves from that day forward to sing praises to God and to preach the thrice Mighty because He had given them so much wisdom and power and so great an Empire over all other creatures.

#### THEOREM XXIV

Just as we commenced the first theorem of this little book with the point, the straight line, and the circle, and have extended it from the Monadic point to the extreme linear efflux of the Elements in a circle, almost analogous to the equinoctial which makes one revolution in 24 hours, so now at last we consummate and terminate the metamorphosis and the metathesis of all possible contents of the Quaternary defined by the number 24 by our present twenty-fourth theorem, to the honour and Glory of Him, as witnesseth John

the Archpraesul of the Divine Mysteries, in the fourth and last part of the fourth chapter of the Apocalypse, who is seated on His Throne, around and in front of which the four animals, each with six wings, chant night and day without repose: “Holy, Holy, Holy is the Lord God Omnipotent, who was, is and is to come,” the same as the 24 ancient ones in the 24 seats placed in the circle, adore Him and prostrate themselves, having cast their Crowns of gold to earth, saying: “Worthy art Thou, O God, to receive Glory, Honour, and Virtue, because Thou hast created all things, and out of Thy Will they have been created.”

Amen.

Says the fourth letter.



He to whom God has given the will and the ability to know in this way the Divine mystery through the eternal monuments of literature and to finish with great tranquillity this work on the 25th January, having commenced it on the 13th of the same month.

In the year 1564 at Antwerp.

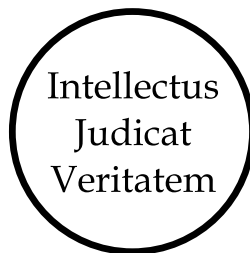

## CONTRACTUS AD PUNCTUM

Here the vulgar eye will see nothing but Obscurity and will despair considerably.



# Compendium Heptarchiæ Mysticæ

of Dr. John Dee

## Compendium Heptarchiæ Mysticæ; Diuinis ipsius Creationionis stabilitæ legibus Diuinis.

### Cap. 1.

#### Of the Title, and generall contents of this boke, some nedefull {Testimonies}

Δ {Sapi}entia ædificavit {sib}i  
domum: excidit {co}lumnas  
Septem. Prouerb. 9. {"Wisdom  
has built her house, she has set up  
her seven pillars." Pr.9.}

Beware of wauering: Blot out suspition of vs. for we are gods Creatures,  
that haue Raigned, do raigne, and shall raigne for euer. All our Mysteries  
shalbe known vnto you. &c. Behold, these things and their mysteries  
shalbe known vnto you, reserving the secrets of him that raigneth for  
euer. [the voyce of a Multitude answered, singing, Whose name, is great  
for euer]

{Anno} 1582. Novemb. 16.  
{B}ralges, the last of 7 Princis  
{co}ncluding the first {bo}ke  
with his words. {Sl.3188, pp. 80}

Open your eyes, and you shall see from the highest to the lowest. The  
peace of God be vpon you.



King Carmara, straight way  
sayd as followeth.

Venite, gradatim repetamus opera Dei, &c. [Δ Lib<sup>o</sup> 1<sup>o</sup> Principes solu-  
loquebã {tur} ... secundo Reges, proxime (?).]



King Carmara, Nouemb.  
17 {Sl.3188, pp. 81}

Vnus est Deus, et vnum est opus nrm.

[Very many cam vpon the convex superficies of the Transparent globe  
and sayd] Parati sumus servire Deo nostro.

Hagonel

This work shall haue relation to tyme present, and present vse. To  
Mysteries far exceeding it: And finally, to a purpose and Intent, Wherby  
the Maiestie and Name of God, shall, and may, and, of force must  
appare; with the Apparition of his wonders, and mervayles yet unhard  
of. Dixi.



Camara, Novemb: 19,  
{Sl.3188, pp. 92}

Δ -- Note As Vriel and Michael at the begynning of this Art, were present  
and gaue Authoritie to Carmara to order the whole: so, at the Conclusion  
they appered againe, and Raphaël with them: and Michael concluded the  
^second boke with these words: ¶Mercifull is our God, and glorious is his

Michael, Novemb. 19.

Name: which Chuseth his Creatures, according to his owne secret Iudgment and good pleasure. This Arte is the first part of a Threhold Arte, ioyning man, (with the knowledg of the 1. World, the 2. Gouernment of his Creatures, and the 3. Sight of his Maiestie) Vnto him, (ô I say, vnto him) which is Strength, Medicine, and Mercy, to those that feare him. Amen.

Thow hast a work of Three proportions in Esse, of Seuen in forme: which is (of it self) diuided by a number Septenarie. Of the Cowrse, estate, and detemination of things above, things next, and things below: which of it self is pure, perfect, and without blemish. &c. King Carmara, Nouemb. 21. in Appendix to the second boke.

Ô God, how easy is this first understanding? Thow hast byn told perfectly, playnely, and absolutely, not onely the Condition, dignitie, and estate of All things that God hath framed: But also withall, thow wart deliuered, the most perfect forme and vse of them. &c. Carmara, Nouemb. 21.

Euen as God is iust, his iudgments true, his mercyes unspeak {able,} so are we the True messagers of God: and our words are true in his Mercy, for euer. Glory, (ô Glory) be to thé, ô most High God. King Carmara, die 17 Nouemb. {Sl.3188, pp. 85}

{Several additional paragraphs appear in HM, Sl. 3191.}

Δ -- Amen.

He that standeth in the myddst of the Globe signifieth NATURE: whereuppon in the first point, is the use and practise of this work: That is to say, as concerning the first part, for it is sayde:

The boke conteyneth three kinds of knowledges.

Uriel, May 5, 1583. {Sl. 3188, pp 180}

- The knowledge of god truely
- The number & doing of his Angells perfectly
- The begynning and ending of Nature Substantially.

---

## Cap. 2

### **Δ Of John Dee his principall, and (in manner) peculiar Interest, to exercise the Doctrine of the boke Heptarchicall.**

Vltima est hæc ætas vram, quæ tibi revelata erit.

{Anno 1582 Uriel, Nouemb.} 15

The Mysteries of God haue a tyme: and behold, thow <sup>Δ</sup> art provyded for that tyme.

Michael

The Sonnes of men <sup>Δ</sup> light, and theyr Sonnes are subiect unto my commandment: This is a Mys {terie:} I haue spoken of it. Note it thorowghly: they are my Servants. By them Thow <sup>Δ</sup> shalt work mervayles.

Hagonel, {No}vemb. 16.

There are kings fals and uniuert, whose powre as I haue augmented <sup>Δ</sup> subuerted and destroyed, So shall Thow.Δ.

Hagonel, {No}vemb. 16.

The second Assembly were the Governours of the Erth, whose glory, (if

..dem, eodem, tempore.

they be good) the weapons we haue towght thé<sup>Δ</sup>, will augment, and consequently, (yf they be evyll,) pervert.

I am Bornogo. This is my Seale, this my true Character. What thou<sup>Δ</sup> desyrest in me, shalbe fullfilled. Glory to God.

Bornogo, {No}vemb. 16.

Behold, Behold, lo Behold my mighty powre consisteth in thys. Lerne wisdom by my words. This is wrowght for thy<sup>Δ</sup> erudition, what I instruct {hm: entrust} thé from God. Loke unto thy charge truely: Thou art yet dead. Thou shalt be revyved. But oh, blesse god truely. The blessing that God giveth me, I will bestow uppon thé, by permission {hm: "omission"}. Ô how mighty is our god, which walked on the waters, which sealed me with his name. Whose Glory is withoute ende. Thou hast written me, but yet dost not know me. Use me in the name of God: I shall at the tyme appoynted be ready. I will manifest the works of the Seas: and the miracles of the Deape, shall be known.

{B}efafes, {eo}dem die

Behold, thou desyrest, and art syck with desyre: I am the disposer though not the composer of Gods Medicines. Thou desyrest to be cumforted ~~in~~ thy labors and strengthened in thy labors: I mynister <sup>unto thé</sup> the strength of God. What I say is not of my self: neyther that which is said to me, is of them selves, but it is sayd of him which liueth for euer. These Mysteries hath God lastly, and of his great Mercyes graunted unto thee. I haue answered thy dowing mynde. Thou shalt be gluttred, yea filled, yea thou shalt swell and be puffed up with the perfect knowledge of Gods Mysteries in his mercies.

Carmara, die 17. {No}uemb.

Abuse them not. Be faithfull, Use Mercy. God shall enriche thé: Banish wrath: yt was the first\*, and is the greatest commaundment. I rayng by him: and live by him, which rayngneth and liueth for euer.

{\* A}nnael gaue me ..e as ... appears Anno 1581.

I haue shewed thé perfectly: Behold I teach thé agayn: O how mercifull is God that revealeth so great Secrets to flesh and blud. Thou hast 42 letters. Thy Tables last, conteyn so many &c.

{C}armara. {di}e 17 Novemb.

Whan thou wilt work for any thing apperteyning unto the estate of a good King: Thou must first call uppon him, which is theyr prince. Secondly the ministers of his powre ar six &c.

{C}armara eodem tempore.

In owtward sense, my words are true: I speak now of the use of one of the first, that I spak of, or manifested yesterday. Sayd I not, and shewed I not, which had the government of Princes? for as it is a Mysterie to a farder matter, so is it a purpose to a present use. Yf it rule worldly princis, how much more shall it work with the Princis of Creation? Thou desyrest use. I teach use. And yet the Art is to the farder understanding [168f] of all sciences, that are past, present, or yet to come.

{eodem} tempore.

Frute hath farder vertue, then onely in the eating: Gold his {farder} condition, property and quality, then in melting, or common use. Kings there are in Nature, with Nature, and above Nature. Thow {art} Dignified. &c.

Last of all thy Ryng, which was appointed thé with the Lamyne comprehending the forme\* of thy own name. Which is to be made in pf{ect} gold: as is affore sayde.

{vi}de A<sup>o</sup> ... {Ca}rmara: {eo}dem tempore.

Thou shalt be cumforted. But respect the world to come: Whereunto thow art provyded, and for what ende: and that, in what tyme. Serve god truely,

Serve him justly. Great care is to be had, with those that meddle with princis affayres: Much more consideration, with whome thou shalt meddle, or use any practise. But God hath shadowed thé from destruction. \*E.K.  
He preserveth his faithful, and shaddoweth the iust, w<sup>th</sup> a sheld of honor.  
None shall enter into the knowledg of thes mysteries with thé, but this worker\* &c.

Finally God doth enriche thé with knowledg: and of thy self hath given the understanding of these worldly vanities. He is mercifull: And we his good Creatures, neyther haue, do, nor will forget thé. God doth bless you both: whose mercy, goodnes and grace, I pronownc and utter uppon you. I haue sayd.

Dee, Dee, Dee, At length, but not to late.

[Δ as concerning these Mysteries atteyning &.]

King Bobogel, Novemb. 19.

Lo thus thou seest the Glory of Gods creatures: whom thou mayst use, with the consideration of the day, theyr King, theyr prince and his character: The King and Prince govern for the hole day: the rest according to the six parts of the day. Use them to the glory of God prayse and honor of him, which Created them, to the laude and prayse of his Maiestie. King Carmara, Novemb. 20.  
Write this reverently. Note it with submission. What I speak hath not byn revealed, no not in these last tymes of the second last world &c.

Thou shalt work marvaylous marvaylously by my workmanship in the Highest.

King Bynepor, {di}e 20.  
{N}ovemb.

Unto my Prince (my Subiect) are deliuered the keys of the Mysteries of the earth. All these are Angels, that govern under him: &c. Use them, They are, and shalbe at thy commanndement.

King Bnaspol. die 20. Novemb.

By me thou shalt cast out the powr of all wycked Spirits.

By me thou shalt know the doings and practises of evyll men: and more then may be spoken, or uttred to man.

King Bnaspen, die 20. Novemb.

Ô quanta est ho[mi]nis Infirmitas et Corruptio, qui Angelis, idq̄ suis bonis, fidem autem Deo, vix habet? O[mn]ia Mundana fæces; Mundi corruptiones in se habent. Deus nr, Deus nr, Deus (inquam) ille nr, Verus cum veris suis Angelis, eiq̄ servientibus, semper verus est Pete quae vis.

Dixi et quod dixi Obumbratum est veritate, Justitia, et perfectione

Ecce -- Δ -- holding up the meat rod

King Carmara, Novemb. 21

Hic -- Δ pointing to the ende of the rod

Per hoc, pointing to the Middle of it.

Et a mensuræ fine, nos nostramq̄ mensurabis potestatem. Age (inquam) Quid vis? &c.

Obscurum enim Nihil est, quod per illum<sup>EK:</sup>, recepisti<sup>Δ</sup>. Age

One thing is yet wanting, a mete receptacle &c. There is yet wanting a

King Carmara, Novemb. 21.

stone. &c.

One there is most excellent, hid in the Secret of the depth &c. In the uttermost part of the Roman possession. &c. Lo the mighty hand of God, is uppon thé &c.

Thow shalt prevayle with it, with kings and with all Creatures of the world: whose beautie (in vertue) shall be more worth then the kingdomes of the earth &c. Go toward it and take it up &c. Kepe it sincerely: Let no mortall hand touch it but thy own.

[168v] Thy Character must haue the names of the five Angels (written in the myddst of Sigillum Æmeth) graven uppon the other side, in a circle. In the myddst wherof must the stone be, which was allso browght. Wherein Thow shalt at all tymes behold (priuately to thy self) the state of Gods peop{le,} through the whole earth.

Go and thow shalt receyue. Tary and you shall receyue. Slepe and you shall see: But watch and yo<sup>r</sup> eyes shalbe fully opened. One thing which is the grownd and Element of thy desyre, is allready perfited &c. Out of Seuen Thow hast byn instructed, of the lesser part most perfectly.

All those before spoken of, are Subiect to thy Call. &c.

Of friendship, at any tyme, thow mayst see them, and know what thow wylt.

Euery one (to be short) shall at all tymes and seasons, shew thé Direction in any thing &c.

One thing I answer thé, for all Officis: Thow hast in subiection all Officis: Use them when it please thé: and as thy Instruction hath byn.

The Lord sayeth, I haue hardened the hart of one of you: yea I haue harden{ed} him, as the flynt: and burnt him together with the ashes of a Cedar. To the Intent, he may be proued Just in my work: and great in the strength of my glory: Neyther shall his mynde consent to the wyckednes of Iniquitie. For from Iniquitie, I haue Chosen him to be a first Earthly wytnes of my dignitie.

{HM includes several more paragraphs, and omits the following concluding paragraph.}

Δ Soli Deo Omnipotenti omnis honor et Gloria. Amen.

### Cap. 3: <sup>^</sup>Some remembrances **Of the necessary furniture** <sup>^</sup>and Circumstances necessary in **for the exercise** **Heptarchicall.**

First cast thy ey unto the generall prince, Governor, or Angel, that is Principal in this world. Than place my name, whome thow hast allready.

Than the Name of him, that was shewed thé yesterday, [w<sup>th</sup> the short cote.] Then his powre, with the rest of his six perfect ministers.

... {corner of leaf torn; HM has Anno 1583 May 5} ???=  
...?? Car=  
... ?? caue (?)  
{B}aligon.

Raphael A<sup>o</sup> 1583. Martij 23.

Raphael, Marty 26. Anno 1583. {HM lists the date as March 23, however, per Sl. 3188, 'All those...' and 'Euery one...' were March 26. The third quote is no longer extant in Sl.3188, but HM lists the date elsewhere as March 15.}

Uriel, A<sup>o</sup> 1583  
Aprilis 23:

Was it not Annael:  
w<sup>th</sup> whome I  
had the preface to  
this new exercise  
{t}estimony (?):

With these thow shalt work to a good ende. All the rest thow mayst use vide sup. pagina, to gods Glory. for every one of them shall minister to thy Necessities. ..., libra prima.

Moreover when thow workest, thy fete must be placed upon these Tables, which thow seest wrytten last: comprehending 42 letters and names. But with this consideration, that the first Character, which is the first of the 7, in thy former boke be placed upon the top of the Table, which thow wast, and art & shalt be commaunded to haue and use.

King Carmara  
in the presence  
of Michael  
A° 1582.  
{No}vemb.17.

Last of all the Ring, which was appointed thé, with the lamyne Comprehending the forme of thy own name. which is to be made in perfect gold: as is affore sayd.

Euen as god is Just ~~hast~~ his Judgments true, his mercies unsp{akable}  
So are we the True Messengers of God and our words are true in his mercy for euer. Glory ô glory be to thé ô most high God.

Lo, thus thow seest the glory of gods Creatures: whome thow mayst use, with the Consideration of the day, theyr King, theyr Prince and his King Chara{cter.} The King and Prince govern for the whole day. The rest {C}armara. according to the six parts of the day. Use them to the glory, prayse & ??? Novemb. 20. honor of him, which Created them, to the laude and praise of his Maiestie.

[169r]

The Characters of the kings are in the Globe: and {of the Princis,} in King Carmara, Novemb. 21. the Heptagonon.

The sonns of light <sup>Δ light</sup>, and theyr Sonns, are Subiect unto my Cōmaund{ement.} This is a Mysterie, I haue spoken of it. Note it throughly. They {are} my Servants. By them thow shalt work Hagonel. mervayles. My time {is} yet to come. The Operation of the Erth is Novemb. 16. Subiect to my powre. And I am the first of the Twelue. My Seale is A° 1582. called Barees. And here it is.

In his Name = Carmara, with my name, by my Character, & the rest of my Ministers are these things brought to pass. Prince Hagonel.

1. These that lye here are witches, enchanters, Deceyvers, Blasphemers. And finally all they that use Nature with Abuse: and dishonor him which rayngneth for euer.
2. The Second Assembly wer the Governors of the Erth, whose Glory, if they be good, the weapons which we haue ~~towght~~ towght thé, will augment And consequently, (yf they be euyll,) will pervert.
3. The Third Assembly, are those which tast of Gods Mysteries, and dr{ink} of the Juyce of Nature: whos myndes are diuided: Some with eyes loking toward heven: The rest to the Center of the erth.

Vbi non gloria, nec Bonitas, nec bonum est. It is wrowght, I say, it is wrowght (for thy understanding) by the Seven of the Seven, which were the Sonns of Sempiternitie: whose names thow hast written and

recorded to Gods glory.

Mark this: All Spirits enhabiting within the Earth, where theyr habitation is of force, not of Will, (Except the midest of my self which I know not) are Subject to the powre hereof [pointing to his seale] with this you shall govern: With this you shall unlok: with this, (in his name, who raineth) you shall discouer ~~your~~ her entrayles.

Whan thou wilt work <sup>^for</sup> any thing apperteyning unto the estate of a good king, Thow must first call upon him which is theyr Prince. Secondly the ministers of his powre are Six: whose names conteyn 7 letters apece: as thy Tables do manifest: by whom in generally, or by any one of them, in particularitie, Thow shalt work for any intent or purpose. As concerning the letters particularly, They do concerne the Names of 42. which 42, in generally or one of them do and can work the destruction, hindrance or annoyance of the estate, condition, or degree, as well for body as government, of any wycked or yll liuing Prince. &c.

Venito BOBOGEL, Rex et Princeps Nobilitatis: Venito cum ministris: Venito (inquam): Venito cum Satellitibus tuis, munitus.  
[Δ This I note for a form of calling]

Veni Princeps, 7 principum, qui sunt Aquarum principes: Ego sunt Rex potens et mirabilis in Aquis: cuius potestas est aquarum visceribus.

Venito, Veni (inquam) Adesto. Veni Rex. O Rex, Rex, Rex Aquarum. Venito Venito (inquam). Magna est tua, Maior autem mea potestas.

Vitam dedit Deus omnibus Creationis. Venite, Veni Ignis, Veni Vita Mortalium (inquam) Venite. Adestum Regnat Deus. O venite. Nam unus ille regnat, et est vita viuientium.

Venite, ubi, nulla quies, sed stridor dentium

{[In space between paragraphs:} Behold euey one of these Princis hathe his peculier Table.

Venite vos, qui sub mea estis potestate

Thy Character must haue the names of the five Angels written (in the myddst of Sigillum Æmeth) graven uppon the other syde in a circle. In the mydst wherof, must the Stone be, which was allso browght: wherein thou shalt at all tymes, behold (priuatly, to thy self) the state of Gods People, through the whole earth.

[169v]

The 4 fete of the Table, must haue 4 hollow things of Swete wood wh{ereuppon} they may stand: Within the hollownes wherof, thy Seales may be kept unpr{ished.} One month is all for the use therof.

The sylk must be of diuers cullors: the most changeable that can be got{ten.} For who is hable to behold the glory of the seat of God.

Δ -- The Character or Lamyne for me, was Noted (Nouemb. 17 A<sup>o</sup> 1582) that it shold conteyne some token of my name: And, now, in this, accownted the True Character of Dignification, I perceyue no peculier mark or letters of my name.

Prince Butmono said this; but the office is ascribed under king Bnaspol to Prince Blisdon: The Mystery therof I know not yet.

King Carmara. Novemb. 17

1582  
King  
Carmara  
die 17. Novemb.

King Babalel to his prince: Novemb. 17.

Ki{ng} Carmara eodem tempor.

{K}ing Carmara  
eodem tempore.

{K}ing Car. eodem tempore.

Carm. Novemb. 2.

Carmara.

Uriel  
1583. Maÿ. 5.

{Uriel, 1583,} May 5.

The cullor was shewed red and greene interchangeably. Nouemb. 21. A<sup>o</sup> 1582

Uriel - 1583. Maÿ. 5.

The forme in euery corner, considereth thy Name. Δ you meane, there to be a certayn shaddow of Delta Δ -- Uriel - Well.

Δ - What is the use of the 7 Tables, (like armes) and from what grownd are they framed, or deriued?

Uriel - They are the ensignes of the Creation: wherewithall they were created by God: known onely by their acquayntance, and the manner of theyr doings.

Δ - haue I rightly applyed the dayes to the kings -- Uriel - The dayes are rightly applyed to the kings. &c.

Δ - The characters and words annexed to the Kings names in the utter Circumference of the great Circle or Globe: How are they to be used?

Uriel - They are to be paynted upon swete wood, & so to be held in thy hand as thow shaltt haue cause to use them.

-----  
Sigillum Æmeth is to be set in the myddle of the Table.

II, Aprilis 28, 1583.

-----  
Grace, mercy and peace be unto the liuely branches of his flourishing kingdome and strong art thow in thy glory, which dost unknütt the Secret parts of thy liuely workmanship: and that, before the weak understanding of man. Herein is thy powre & Magnificence opened unto man. And why? bycause thy Diuinitie and secret power, is here shut up in numero Ternario et Quaternario. A q<sup>o</sup> principium, et fundamentum omne huius est tui sanctissimi ~~maximi~~ (?) operis. For yf thow (O God) be wunderfull & incomprehensible in thyne owne substance, it must nedes follow, that thy works, are likewise incomprehensible.

But Lo, they shall now beleue, bycause they see: which heretof{ore} could skarsly beleue. Strong is the Influence of thy Supercelestiall powre: and mighty is the force of that arme, which overcommeth all things. Let all powre (therefore) rest in thé. Amen.

Leave oute the Bees of the seven names of the 7 kings, and 7 Princis. and place them in a Table diuided by 12 and 7. the 7 spaces, being uppermost: and therein write in the upper lyne, the let{ters} of the king, ~~with~~ with the letters of his prince following, next after his name: and so of the Six other, and theyr princis. And read them on the right hand, from the upper part to the lowest. and thow shalt finde, then, the Composition of this Table. Therin they are all comprehended, sauing certayn letters, which are not to be put-in here: By reason that the Kings, and Princis do spring from God: and not God from the Kings and Princis: Which Excellency is comprehended and is allso manifest, in that Third and fowrth Number. {in marg: Number}

Rownd about the sides [of this square <sup>^Table</sup>] is euery letter of the 14 na{mes,} [170r] of the 7 kings and princis.

Hereafter shall you perceyue that the Glory of this Table {surmownteth} the Glory of the Sonne. All things els that appertayne unto it, {are} already prescribed by your former Instruction.

God is the begynning of all things, but not after one soft: Nor to euery One alike. But it is Three manner of works with his Name. IL. Aprilis 29.

- The One in respect of Dignification 1
- The Second in respect of Conciliation
- The Third in respect of an ende and determined Operati{on.}

Now, (Syr,) to what ende wold you wear your Character? &c.  
Δ At our first dealings to gither it was answered by a Spirituall Creature, (whome we toke to be Uriel,) Sigillum hoc in auro sculpendum, ad defensionem Corporis omni loco, tempore et occasione, et in pectus gestandum.

II - But how do I teach? The Character is an Instrument appliable Onely to dignification. But there is no Dignification (Syr) but that which doth procede, and hath his perfect composition Centrally, in the Square number of 3 and 4. The Center wherof shall be equal to the greatest. Hereby you may gather, Not onely to what ende, the Blessed Character (wherewith thow shalt be dignified) is prepared: but also the Nature of all other Characters.

To the Second - Δ - Conciliation you meane.

II - The Table is an Instrument of Conciliation. And so are the other 7 Characters, which you call by the name of Tables: Squared out into the 2 forme of Armes: which are proper to euery King and Prince according to theyr order.

Now to the last - Δ - As concerning the ende and determined Operation

IL - It consisteth onely consisteth in the mercy of God, and the Characters of these bokes. &c. 3

Set down the Kings and theyr Princis in a Table as thow knowest them: with theyr letters backward: excepting theyr Bees, frō the right hand to the left. Let Bobogel be first, and Bornogo is his prince. &c.

**Note.** IL

and so on the backside of my Character or golden square Table, and ???feth all the names of the 7 kings and theyr 7 Princis: the generall little <sup>^B</sup> B, absented from e?ho?? ?????mentally (?) allwayes conteyned (?) to be pies???d to ech name: as well as in the great table.

{Δ - Note, he}re, it may appere that Butmono is Prince to Bynepor, and Blisdon prince to King Bnaspol.

De Sigillo Æmeth; alr, vocato Sigillo Dei.

Michael - I will shew thé ?????, in the mighty hand and strength of God, what his Mysteries are: The true Circle of his æternitie: comprehending all vertue: The whole and Sacred Trinitie:

Michael, 1582, Martÿ 19.

Oh holy be he: Oh holy be he: Oh holy be he.

Uriel answered, Amen.

Mich - Now, what wilt thou? Δ - I wold full fayne procede according to the matter in hand.

Mich - Diuide this owtward Circle into 40 equall partes: whose greatest numbers are 4. See thou do it presently - Δ - I did so diuiding it first into 4, and then every of them, into 10.

[170v]

He called one by name Semiel.

One cam in and kneled down: and great fyre came out of his mowth. Michael sayd: To him are the Mysteries of these Tables known. Michael sayd, Semiel, (agayn) and by and by he<sup>Michael</sup> sayd, O God thou hast sayd, and thou liuest for euer. &c. ~~Do not think here to speak to him:~~ Semiel stode up, and flaming fyre cam out of his mowth, and than he saide, as followeth.

Sem - Mighty lord, what woldst thou with the Tables?

Mich - It is the will of God Thow fatch them hither.

Sem - I am his Tables. Behold these are his tables: Lo where they are.

Δ - There cam-in 40 white Creatures, all in white silk long robes, and they like Children. And all they falling on theyr knees, sayd:

Thow onely art holy among the Highest, O God thy Name be blessed for euer.

Δ Michael stode up out of his Chayre, and by and by all his legs, semed to be like two great pillers of brass: and he as high as half way to heven: And by & by his sworde was all on fyre: & he stroke or drew his sword over all these 40 <sup>theyr</sup> heds. The erth quaked: And the 40 fell down. And Michael called Semiel with a Thundring voyce & sayd, Declare the Mysteries of the Liuing God, Our God, of One that Liueth for euer.

Sem - I am ready.

Δ - Michael stroke ouer them with his sword: and they all fell down (& Uriel ~~ap~~ also) on his knees. And commonly at the striking with the sword, flaming fyre, (like lightening) did flash with all.

Michael - Note. here is a Myserie.

Δ - Then stept furth one of the 40 from the rest: & opened his breast,



which was covered with sylk and there appeared a great all of gold.

Mich - Note the number. Δ over the T, stode the Number of 4, on this



fashion

Δ - The 40, ~~erred~~ all cryed: Yt liueth and Multipliyeth for euer: blessed be his name.

Δ - That creature did shut up his bosome, and vanished away like a fyre.

Michael - Place that in the first place. It is the Name of the Lord.

Δ - Then there semed a great clap of Thunder to be &e-

Δ - And so furth. the whole second boke is nothing els but the Myseries most Mervaylous of Sigillum Dei, otherwise called Sigillum Æmeth. wherof here I did here but leave some ?????y {HM reads: admonishment}, &c.

Note also, the Third boke was chiefly of the 7 ensignes of Creation. &c. mentioned in this Chapter of in the ^?????? of orations (?).

---

[171r]

## Caput 4.

**Some Notice of peculier formes, wherein the Kings, Princis, and Ministers Heptarchicall appeared.**

### King CARMARA

Appeared as a man, very well proportioned: in a long purple Robe, and

with a Triple Crowne of Gold on his hed.

At his first comming in, he had 7 <sup>like</sup> men waighting on him: which afterwarde declared them selves to be 7 princis under the 7 Heptarchicall Kings.

Uriel deliuered to him, at his first appearing, (which he kept still in his hand) a rod, or straight little rownd staf of gold diuided into three distinctions: whereof two were dark, or blak, and the Third, bright red.

**Note.**

At the first, Uriel pluckt a thing from under the <sup>Covenant</sup> Table: and it grew Rownd, Bigger & bigger, (of fyrie Cullour) bigger then all the world: and <sup>he</sup> sayd to me <sup>Δ</sup> Vltima est hæc ætas vestra quæ tibi revelata erit. Then cam swarming into the stone, Thowsand yea Innumerable people, Uriel sayd, Est in mundo, et ~~cum~~ incipiet cum illo alter Mundus. and he bad, Note the forme of the thing seen. Note the cullour. The forme of the thing seen was a Globe Transparent fyre within which the people seemed to stand, Towers and Castells. &c. did appere therein, likewise. This Globe did king CARMARA seeme to go uppon, & to measure it: and there appeared a very riche chayre to be set: allmost at the top of the Convexitie of the sayd Globe. wherein he sat down.

Uriel

**Prince HAGONEL**

Note. All the 7 Princis, seemed to <sup>be</sup> men, and to haue red robes, but this Prince, his Robe, was shorter then the others. They had all Cerclets of  <sup>above</sup> on theyr heds, he had a rownd Ring with a prik in the myddle which he affirmed to be his seale. The name therof he sayde to be



Barees, and that it is

The Sonns of light <sup>men</sup> and theyr Sonns, are Subiect unto his commaundement. They are his Servants. Their Apparition appereth, the first 7 ~~like little boyes~~ yong men, the other 7 like little boys. [loke on the other side]

Ministers  
Filij Lucis  
Filij filiorum lucis  
???erte (?) filiam (?)

**Note**

King Carmara, did first Call the Princis <sup>7</sup> before him: and they stode three on one side of him, and three on the other: But this Prince Hagonel, he toke, and set him in the myddle before him, as he sat in the Chayre, on the Convexity of the Transparent fyrie Globe. And after ward he called but five kings: for he him self, supplied two places of Kings, governing on Monday, and fryday. Blumaza he dyd not ones

speak of: I know, not yet, the Mystery therof.

{blank page}

[172r]

Rex -- BLVMAZA  
---

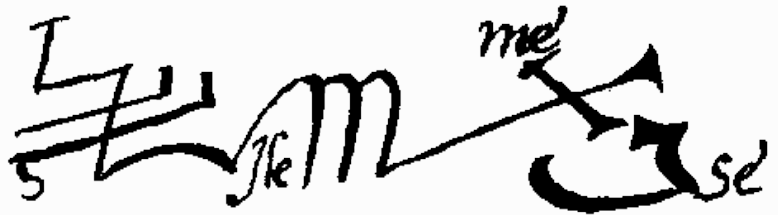

Princeps Bralges ---  
--



Sapientia ædificauit sibi  
Domum: excidit  
Columnas  
Septem. Prouerb. 9.

### Die Lunæ {Monday}

|   |   |   |   |   |   |   |
|---|---|---|---|---|---|---|
| O | E | S | N | G | L | E |
| A | V | Z | N | I | L | N |
| Y | L | L | M | A | F | S |
| N | R | S | O | G | O | O |
| N | R | R | C | P | R | N |
| L | A | B | D | G | R | E |

{**Note:** The ms. has F with a dot under it in the second square of the first row, with an E (also with a dot under it) above it. The circle is from HM; that in CMH is blank. -JHP}

CARMARA Rex

Hagonel



Princ{eps}

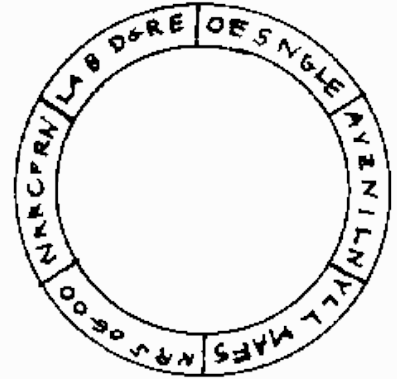

Shewed onely in square

Die Dominica. {Sunday}

|   |   |   |   |   |   |   |
|---|---|---|---|---|---|---|
| L | E | E | N | A | R | B |
| L | N | A | N | A | E | B |
| R | O | E | M | N | A | B |
| L | E | A | O | R | I | B |
| N | E | I | C | I | A | B |
| A | O | I | D | I | A | B |

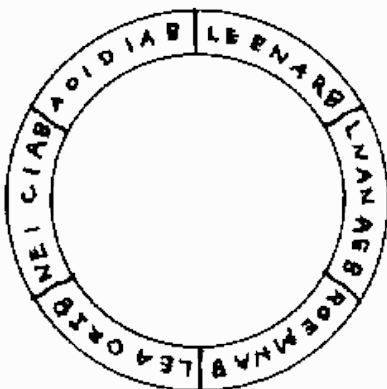

BOBOGEL

Rex

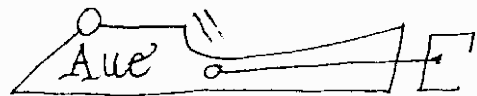

BORNOGO

Princeps



both square and rownd

### Die Martis. {Tuesday}

|   |   |   |   |   |   |   |
|---|---|---|---|---|---|---|
| E | I | L | O | M | F | O |
| N | E | O | T | P | T | A |
| S | A | G | A | C | I | Y |
| O | N | E | D | P | O | N |
| N | O | O | N | M | A | N |
| E | T | E | V | L | G | L |

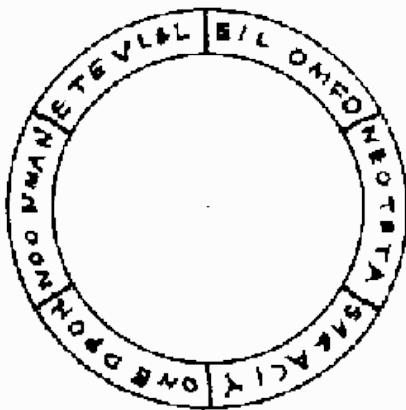

BABALEL

Rex

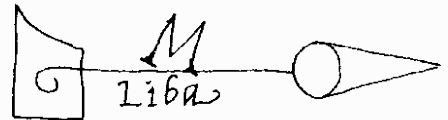

BEFATES

Princeps

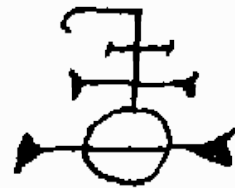

Onely shewed in square

[172v]

Die Jouis. {Thursday}

BYNEPOR

Rex

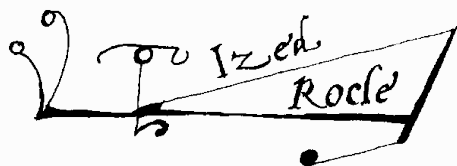

BVTMONO

Princeps

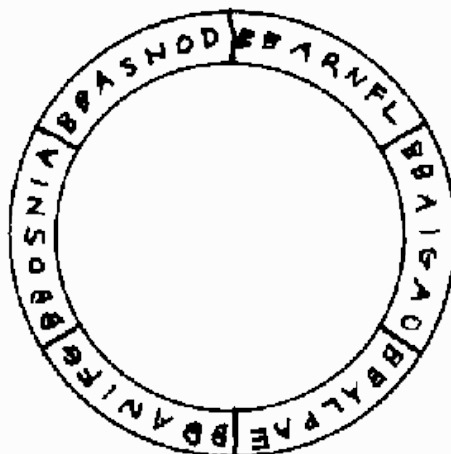

|   |   |   |   |   |   |   |
|---|---|---|---|---|---|---|
| B | B | A | R | N | F | L |
| B | B | A | I | G | A | O |
| B | B | A | L | P | A | E |
| B | B | A | N | I | F | G |
| B | B | O | S | N | I | A |
| B | B | A | S | N | O | D |

Shewed onely in square.

fol. 3. l:

Behold, this is my Seale. &c.

All spirits inhabiting within the earth, (where their habitation is of force, not of will) are subject to the powr hereof. With this you shall govern, with this you shall unlok: With this (in his name who rayneth) you shall discover her entrayles. &c.

Die Mercurÿ {Wednesday}

BNASPOL

Rex

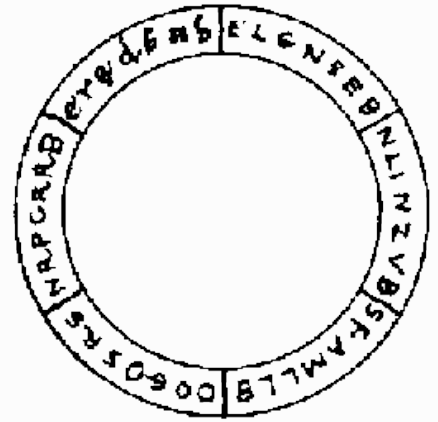
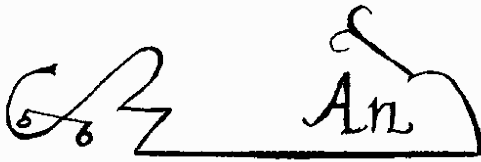

BLISDON

Princeps



|   |   |   |   |   |   |   |
|---|---|---|---|---|---|---|
| E | L | G | N | S | E | B |
| N | L | I | N | Z | V | B |
| S | F | A | M | L | L | B |
| O | O | G | O | S | R | S |
| N | R | P | C | R | R | B |
| e | r | g | d | b | a | b |

Shewed onely in circle  
{sic}.

**Die Sabati. {Saturday}**

BNAPSEN

Rex

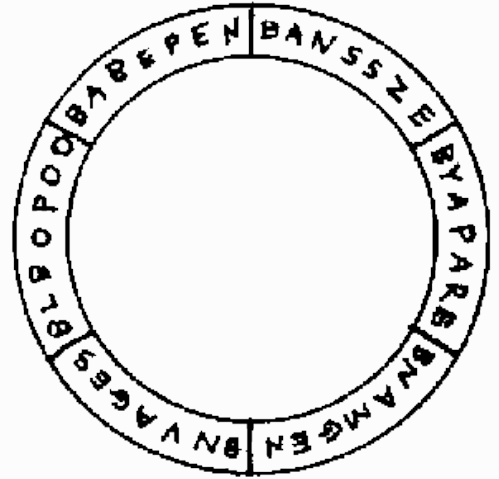

BRORGES:

Princeps



|   |   |   |   |   |   |   |
|---|---|---|---|---|---|---|
| B | A | N | S | S | Z | E |
| B | Y | A | P | A | R | E |
| B | N | A | M | G | E | N |
| B | N | V | A | G | E | S |
| B | L | B | O | P | O | O |
| B | A | B | E | P | E | N |

Shewed onely in Circle.

[173r]

**Die veneris {Friday}**

|   |   |   |   |   |   |   |
|---|---|---|---|---|---|---|
| A | O | A | Y | N | N | L |
| L | B | B | N | A | A | V |
| I | O | A | E | S | P | M |
| G | G | L | P | P | S | A |
| O | E | E | O | O | E | Z |
| N | L | L | R | L | N | A |

Shewed onely in Circle.

BALIGON,

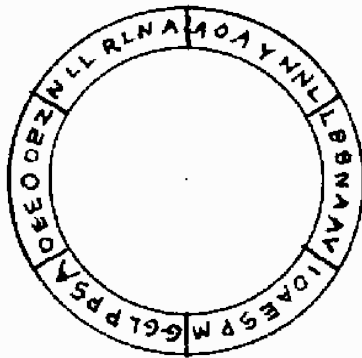

Rex

aliter CARMARA:  
vel MARMARA



BAGENOL

P{rinceps}

| Filij lucis | Filij filiorum |
|-------------|----------------|
| I           | Et E ♀         |
| Ih          | An -- ♀        |
| Ilr         | Aue -- ♂       |
| Dmal        | Liba -- ♀      |
| Heeoa       | Rocle -- ♀     |
| Beigia      | Hagonel -- ♀   |
| Stimcul     | Ilemese -- ♀   |

Potestas Carmara, Marmara, siue upsius Baligon regnat in filiæ (?) -- Rex --  
CARMARA

lib<sup>o</sup> 4<sup>o</sup>. fol 2

The Sonnes of men, and theyr Sonns, are subject unto my commaundement. They are my Servants -- Princeps - Minister



-- Hagon {el}  
primus et {quartus}

This Prince calleth all the People of the earth: and then he commaundeth of three sorts:

1. Kings - Δ Conside {r ..} seameth to ... with Bobogel his office &c.
2. Noble men:
3. Philosophers -- Princes of Nature

I am Primus et Quartus Hagonel.

Here is his Name (pointing to  = Carmara) &c.

Notwithstanding, I am his Minister.

And pointing to Carmara, he sayd. In his name with my name, by my Character, and the rest of my Minis {ters} are these things browght to pas.

It is wrought, by the 7 of the 7, which were the Sonnes Sempiternitie, whose names thow hast written and recorded to Gods Glory:

[173v]

## Bobogel Sunday

-- The distributing, giving, and bestowing of Wisdome and Science: The teaching of true Philosophie, true understanding of all lerning, grownded uppon wisdome: with the excellencies in Nature: and of many other great Mysteries, mervaylously avaylable, and necessarie to the advancing of the Glory of our GOD, and Creator. Therefore, In the Name, &c.

Gloria Patri &c.

## Prince Bornogo Sunday

-- The Altering of the Corruption of Nature, into perfection: The knowledg of Metalls. and generally the Princely Ministring to the right Noble and Mighty King BOBOGEL in his government of Distributing, giving and bestowing of Wisdome, science, True Philosophie, and True Understanding, and of other very many his peculiar Royall Propreties. Therefore, In the Name, &c.

Pater noster &c.

Raphaël. A<sup>o</sup> 158  
{sic}

[174r]

## Rex Carmara Die lunæ Monday

-- Who, <sup>^</sup>in this {Heptarch} icall Doctrine receyuedst at blessed Uriel his hand, the golden rod of government & the Chayre of dignity,; and ~~the~~ ~~Fr~~ didst appeare first to us. Triple Crown in a long purple robe. Who saydst to me at Mortlake, I minister the strength of God unto thé.

Likewise thow saydst, These Mysteries hath God, {lastly,} and of his great mercyes, graunted unto thé.

Thow shalt be gluttoned, y<sup>{ea}</sup> filled: yea thow sha<sup>{llt}</sup> swell, and be puffed up, with the perfect knowledg of Gods Mysteries in his mercies.

And saydst, this Art is to the farder understanding of all sciences, that are past, present or yet to come.

And immediatly didst say unto me: Kings there are, in Nature, wyth Nature, and about Nature. Thow art Dignified.

And <sup>^saydst</sup> concerning the use of these Tables, This is but the first step. Neyther shalt thou practise them in vayne. † ~~Therefore~~, &c.

{in marg:}+ And sayd thus: Generally, of God his mercyes and graces on me decreed, and bestowed: Whatsoever thou shalt speak, do, or work, shalbe profitable and acceptable: And the Ende, shall be good.

## Prince HAGONEL Monday

To whose Commaundement the Sonnes of men and theyr Sonnes ar subiect: and are thy Servants. To whose powre the Operation of the Earth is subiect. Who art the first of the twelue: and whose seale is called Barees, and this it is ☉ At whose Commaundement are the Kings, Noble men, and Princes of Nature. Who art Primus et Quartus Hagonel. Who, by the seuen of the seven (which are the Sonns of Sempiternitie) dost work mervayles amongst the people of the Earth: and hast sayd to me, That I also, by the same thy servants, shold work mervayles. O Noble Hagonel who arte the Minister to the Triple Crowned King Carmara: and Notwithstanding art Prince over these 42 Angels whose names and characters ~~de~~ here are here presented.

Therefore &c.

[174v]

## Rex Blumaza

{One third of the page is blank.}

## Princeps Bralges

-- Who saydst <sup>^to us</sup> The Creatures liuing in thy Dominion, are subiect to thy powre: whose subiects are invisible: and which <sup>^to my seer</sup> appeared like little smokes, with out any forme, Whose seale of gouernment is this: Who saydst, Beholde, I



am come, I will teache thé, Names without Numbers: The Creatures subiect unto me, shall be known unto you, Therefore, In &c.

[175r]

Rex

{in top marg: pronunc...are (?)}

Baligon  
fryday

The shew-stone

Who canst distribute and bestow at pleasure, {all that} what{-so-euer} can be wrought in aereall actions: who hast the government of thy self perfectly: as a mysterie known unto thy self. Who ~~hast answered thé~~ didst aduertise me of this stone and holy receptacle both nedefull to be had, and also didst direct me to the taking of it up, being presently and in a few mynutes of tyme, browght to my sight ^{in marg: frō the uttermost part of the Roman possession, being had ther in the secret of the depth} ~~handing, & possessings (?)~~, as to this day it appereth. Who didst say then unto me, Thow shalt prevaile with it, with Kings and with all Creatures of the world. whose beauty (in vertue) shall be more worth, then the Kingdomes of the earth. for the which purposes here rehersed, <sup>and other,</sup> ~~to be~~ partely, now to be used and enioyed, & <sup>partely</sup> hereafter more abundantly (as the Lord god of hoasts shall dispose) And allso bycause thow <sup>thy self</sup> art governour of thes 42 thy mighty, ¶ faithfull & obedient Ministers: Therefore, In &c.

Rex

Bnapsen  
Saterdag.

-- ~~The government of all enchanters Coniurers, witches and wicked spirits hated of God, and included for euer in outward darknes~~ : Who hast sayd to me, That by thé I shall cast oute the powre of all wicked spirits: And that by thé I shall or may know the doings and practises of euyll men, and more then may be spoken or uttred to man. Therefore &c.

Princeps  
Brorges

-- Who <sup>being the Prince, and chief Minister and governor under thy right Puissant King Bnapsen,</sup> didst appear to my seer in most terrible manner of firy flamyng streams, and saydst Noui Ianuam mortis et percussit gloria Dei Impiorum parietes.

Therefore &c.

[175v]

Rex

Babalel  
Tuesday  
♂

-- Who art King in Waters: Mighty and wunderfull in waters, whose powr is in the bowels of the waters: whose royall person with thy Noble prince <sup>Befafes</sup>, and his 42 Ministers, The Triple Crowned king Carmara bad me vse to the Glory prayse and honor of him which created you all, to the laude and prayse of his Maiestie.

Therefore, &c.

Princeps  
Befafes

-- Who art Prince of the seas: Thy powr is vppon the waters. Thow drownedst pharao: and hast destroyed the wycked. Thy name was known to Moyses, thow liuedst in Israël:

-- Who hast measured the waters: who wast with King Salamon, and allso long after that, with Scotus: but not known <sup>to him</sup> by thy true name: for he called thé Mares. And since thow wast with none: <sup>Except</sup> when <sup>thow</sup> preseruedst me (through the mercy of God) from the powr of the wycked and wast with me in extremities: Thow wast w<sup>th</sup> me throughly: who of the Ægyptians hast byn called Obelison, in respect of thy pleasant

deliuerance: And by that name to me knowne: and of me Noted in record, to be the Noble and Curteous Obelison. Whose Noble ministers 42, are of very great powre, dignitie, and Authoritie: As some in the measuring of the motions, of the waters, and saltnes of the seas, in giuing good success in Battayles, reducing ships, and all manner of vessels that flete uppon the seas: To some all the fishes and monsters of the seas, yea all that liueth therein, are well known: and generally are the distributors of Gods Judgments uppon the Waters that couer the earth. Some conduct waters through the earth: other do beautify Nature in her Composition. The rest are distributors and deliuerers of the Threasors and unknown substances of the Seas: Thow <sup>^O</sup> Noble Prince Befafes badst me use thé, in the name of God. Therefore &c.

[176r]

## Rex Bnaspol Wensday.

To whome the earth with her bowels, and secrets whatsoever, are deliuered: and hast sayd to me heretofore: What thow art, there I may know. Thow art great, but, (as thow truely didst confess,) he in whom thow art, is greater then thow: Therefore, In &c.

## Princeps Blisdon

-- Unto whome the keys of the Mysteries of the earth are deliuered: whose 42 ministers are Angels that govern under thé: All which, thy mighty king <sup>^Bnaspol</sup> bad me use: and affirmed that they are and shalbe at my commaundement: Therefore, In &c.

Il. 1583.  
Thursday  
Aprilis  
18.

Yf thow haue a parcell or part (out of euery place) of the erth, in any small quantity, thow mayst work by the Creatures, whose powr it is to work in such causes, which will bring it (neuer trust me) before you can tell twenty.

[176v]

## Rex Bynepor Thursday

-- Uppon the distribution and participation of whose exalted most especiall and glorified powre, resteth onely and dependeth the generall state and Condition of all things. Whose sanctification, glory and renowne, althowgh it had begynning, yet can it not, neyther shall haue ending. He that Measureth, sayd, and thow wast the ende of his workmanship. Thow art like him, and of him: yet not as partaking or adherent: but distinct in one degree. Whan he cam thow wast magnified by his comming: and art Sanctified, world without ende.

Vita Suprema  
Vita Superior  
Vita Infima tuis sunt  
mensurata manibus.

Notwithstanding, Thow art not of thy self: Neyther is thy powr thyne owne: Magnified be his name. Thow art in all: And all hath some being by thé: yet

thy powr is nothing in respect of his powr, which hath sent thé.

New worlds. Perhaps a new period doth begynn, as I haue set down in the Volume of famous and rich Discoveries.

♃ after ♀  
great period.

Thow begynnest new worlds <sup>Δ</sup>, new people, New Kings, and New knowledg of a New government. And hast sayd to me, Thow shalt work Mervaylous, Mervaylously, by my workmanship, in the Highest. Therefore, In the Name, &c.

## Princeps Butmono

-- Who art life and breath in liuing Creatures: All things liue by thé, the Image of One excepted. All the kindes of ~~the~~ beasts of the earth dost thou endue with life. Thy seale is theyr glory. Of God thou art sanctified. and thou reioysest. The liuing, the ende, and begynning of all beasts thou knowest. and by sufferance thou dispoest them, untill thy Vyoll be runne.

Therefore, &c.

[177r] [177r is blank]

[177v]

### The seven Kings

1. Carmara <sup>^as a man very well proportioned</sup> in a long purple robe. W<sup>th</sup> a Triple crown on his hed.
  2. Bobogel - in a black veluet coat, and his hose close with veluet upperstoks: overlayd with gold lace: With a velvet hat-cap, with a black feather in it. with a cape on one of his sholders: his purse hanging at his neck: & so put under his gyrdell <sup>^at which hong a gylt rapier.</sup> his beard long he had plinufles & pynsions.
- {illegible marg note.}
- He sayd, I wear these robes, not in respect of my self, but of my government.

The ministers cam w<sup>th</sup> ~~him~~ <sup>Bob.</sup> 42, all trymmed after the manner of Nobility now a dayes, w<sup>th</sup> gilt rapers. 7 of them were apparayled like Bobogel, sagely & gravely: all the rest ar ruffyn like. The last 7 do seme to be ~~men~~ both men & women: for ~~before~~ in the forepart they seme to be attyred lik women <sup>^with fardingales</sup>, & in the bak part like men.

3. Babalel - As though he wer a king with a crown <sup>^of Gold</sup> on his hed his apparayle, a long robe whitish. his left arme <sup>^sleve</sup> was very white. & his right arme ~~black~~ sleve, was black. he seamed to stand upon water, his name was written in his forhed: Babalel.

The forme 7 of his 42 <sup>Ministers</sup> haue Cerclets on theyr heds.

<sup>Δ</sup> for king Babalel he first called Befafes, <sup>Θ</sup> <sup>Veni</sup> Princeps in principum, qui sunt aquarum Principes &c. & of these seven the letters seme betwene theyr fete.

4. Bynepor - The ministers 42 like ghostes or smokes without all forme having every one of

5. them a little glittering spark of fyre in the midst of them: and every spark a letter in it.  
Bnaspoll {sic} - With a red Robe & a Crowne on his hed.
- The Ministers semed to haue letters in the palmes of theyr hands. Standing about a little hill of clay. and behinde this a far did stand an Innumerable Company of ugly people.
6. Bnapsen - a king with a crown on his hed.  
Carmara called saying (?)  
Venite, ubi nulla quies, sed stridor dentium.  
{"Come here, where there is no peace, but only the gnashing of teeth." MLQ, Book 4, Nov. 20, 1582}
- The Ministers <sup>men</sup> 42 tossed the Table rownd Table (which they hold) all in fire flaming. & held in theyr {hands}.
7. Baligon - Idem quae Carmara w<sup>th</sup> his triple Crown & long purple roabe.
- his 42 ministers, wer bright people: and besides them All the ayer swarmeth with creatures. Theyr letters were in theyr forheds: They stand in a Circle: They take the letters from theyr forheds & set them in a Circle.

[178r]



The form of the first apparitions Heptago{num} Prm (?)

- Carmara -- Cam first in, hauing 7 waightyng on him and they (as aff afterward appered) were the 7 prin{ces} but Carmara him self semed to be a man of good proportion, with a long purple ga{rment} robe and a triple ~~erowned~~ Crown (of gold) on his {hed.}
- The 7 Princes -- semed to be like men, & they had {red} garments ... {illegible. HM adds they had "cerclets of gold on theyr heds"}
- Hagonel The .1. -- his robe was shorter then <sup>of</sup> the others 6. fol. 14.b. he held a seale 
- Bornogo The .2. w<sup>th</sup> a <sup>gold</sup> coronet or rather a Cercllet about {his hed.}  
<sup>Babalel</sup> called Veni Princeps 7 principum, qui sunt aquarum pr{incipes.}
- Befafes The .3. -- He opened his bosom: and seamed leane: {and} seamed to haue feathers under his roabs. he had a golden girdle: & on it, written, Befafes.
- Butmono fol. 11 -- he had a cercllet of gold on his hed.



He had a long red robe, & a cerclet of gold on his hed.

{cp. HM description of the ministers under Babalel and Befafes} The 42 Ministers had theyr letters in theyr forheds, & they wer 6 rows of 7 in a row. But of the first 7 had the letters betwene theyr fete, {and} water seamed contynually to pass over these letters. At length the 42 diued into the water, & so went a {way.}

Blisdon --

In a Robe of many cullours: & on his hed a cerclet {of Gold.} Δ - Then his red garment, had many cullors in it {...}.

Brorges --

The <sup>6</sup> sixth - he putteth open his cloathes & red apparell and there did yssue mighty fyre out of his sides. most terrible, grysely, & unutterable to be beholden of mor{tal} eye, any tyme.

Bralges --

The .7. -- his Ministers appeared like little smokes, without any forme.

Δ - ... Bynepor  
{illegible note in  
margin}

{ He sayd, Beware of wavering: Blot out suspition {of} us: for we are Gods Creatures, that haue rayned, do ray{ne,} & shall raigne for euer. All our mysteries shalbe k{nown} to you.

Δ { Bagenol appered not, by that name. Perhaps Hagonel was Bagenol. H being put for B. and the letters true {...?}

{ As hath king also ... Carmara, or Marmara, with a greater??? from his proper name Baligon.

Note. Neyther Blumaza nor ~~Brorges~~ appered by name ..... {bottom line of page is damaged and unreadable.

[178v]

[178v is blank]

[179r]

{This page is bound sideways, such that the first line is against the left margin.}

{repetition of 173v}

**Bobogel --** The distributing, giving and bestowing of wisdome and Science: The teaching of True Philosophie, ~~and~~ true understanding, and of all lerning, grownded uppon Wisdome, with the excellencies in Nature, and of many other great Mysteries, mervaylously available and necessarie to the advancing of the Glory of our God, and Creator. Therefore in the Name &c.

**Sunday**

Gloria Patri &c.

# Prince Bornogo

The Altering of the Corruption of Nature, into perfection, The knowledg of Metalls, And generally The Princely Ministring to the right Noble and Mighty King BOBOGEL in his government of Distributing, giving and bestowing of Wisdome, science, True Philosophie, and True Understanding, and of other very many his peculiar Royall Propreties.

--

Therefore In the Name, &c.

Pater noster &c.

[179v]

{This page has only a double circumference circle in the middle of the page, and occupying about half the width of the page.}

[180r]

{This page is also sideways}

Rex Carmara fol. 4. Behold these things and their mysteries shall be known vnto you, reserving the secrets of him that raineth for euer.

--

Bralges -- All our mysteries shall be known unto you.

fol. 46.

Carm -- fol. 5:

[180v]

{This page is also sideways}

O F S N G L E

{blank circle}

[181r]

{This page is also sideways}

{Repetition of page 174r.}

Prince HAGONEL To whose Commaundement the Sonnes of men and theyr Sonnes are subiect: and are thy Servants. To whose powre the Operation of the Erth is subiect. Who art the first of the Twelue: and whose seale is called Barees, and this it is  At whose Commaundement ar the Kings, Noble men, and Princes of Nature. Who art Primus et Quartus Hagonel. Who, by the seven of the seven, which are the Sonns of Sempiternitie, dost ~~thy dost~~ <sup>work</sup> mervayles amongst the people of the earth, and hast sayd to me, that I <sup>also</sup> should by the same thy servants work Mervayles. <sup>Thou</sup> who arte the Minister to the great ~~king~~ Triple Crowned King Carmara: and Notwithstanding art Prince over these 42 Angels whose names & characters are <sup>also</sup> ~~layd under my~~ <sup>??st</sup> fete: as I was {rest is illegible}

[181v]

{This page is also sideways}

{Repetition of page 174r.}

Rex Carmara -- And saydst unto me, What soeuer thou shalt speak do or work shalbe profitable and acceptable: and the ende of it shall be good. &c.

\*A<sup>o</sup> 1582  
Novemb. 17. { Who saydst, to me at Mortlak\*, I minister thé strength of God unto thé.  
Likewise thou saydst, These Mysteries hath God lastly and of his great mercyes, graunted unto thé.  
Thou shalt be gluttid, yea filled, yea thou shalt swell, & be puffed up, with the perfect knowledg of Gods Mysteries in his Mercies.

And saydst, This Art is to the farder understanding of all sciences that are past present, or yet to come.

And immediatly didst say unto me ~~Thow art Dignified~~ Kings ther ar in Nature, with Nature and above Nature.

Thow art Dignified.

-- And as concerning the use of these Tables, This is but the first step: Neyther shalt thou practise them in wayne.

[182r]

{Compare with page 168v.}

Raphael  
A<sup>o</sup> 1583  
Martÿ 23. Go, and thou shalt receyue. Tary and you shall receyue. Slepe and you shall see: But watch and your eyes shall be fully opened. One thing which is the grownd and Element of thy desyre, is allready perfyted &c. Out of Seuē Thou hast byn instructed of the lesser part, most perfectly.

Martÿ 24  
A direction requisite. Euery Organ is voyd of qualitie, unleast a Meane be adiected.: So, is all that thou hast before, more wonderfull, then as yet, profitable, unleast thou be directed and led in unto the true use and Order of the same. &

Martÿ 26-- I haue byn thy Scholemaster, and director to the Sterne, to rule the reason thereof, with those, which can reach the Iudgment therof.

All those before spoken of are subiect to thy Call &c.

Off frendship, at any tyme thou mayst see them, and know what Thow wilt. &c.

Euery one, (to be short) shall at all tymes and seasons, shew thé Direction, in any thing.

[Δ - But they haue Chefe and speciall tymes]

Raphaël Peradventure Thow thinkest I am not in thy Marrow: yes I haue byn long in the highest part of thy body, and therefore am somewhat perswaded of thy meaning.

One thing I answer thé for all Officis  
Thow hast in subiection all Officis  
Use them when it pleas thé: and as thy Instruction hath byn.

Raph. 1583 Martyr 26. - Yt is determined, else wold I not: And may be undetermined, yf you break his commaundements.

Raph. 1583. Aprilis 3. - Cumfortable Instruction is a necessary Medicine.

Ur. -- Aprilis 23 - Sayth the Lord - I haue hardened the hart of One of you, yea, I haue hardened him as the flynt: and burnt him to gither with the ashes of a Cedar: to the intent, he may be proued just in my work, and great in the strength of my Glory. Neyther shall his mynde consent unto <sup>^the</sup> wyckednes of Iniquitie. For from Iniquitie I haue chosen him, to be a first earthely witnes of my Dignitye.

{In margin, sideway:}

Carm. Thow hast byn told perfectly, playnely and absolutely, not onely the condition, dignitie, & Novemb. 21 1582. estate of all things that God hath framed: But also withall, thow wart deliuered the most perfect forme and use of them.

II May 5. 1583. Thy Character must haue the names of ~~God~~ the five Angels (written in the middst of Sigillum Emeth) graven upon the other side in a Circle. In the middst wherof must the stone be: which was also browght: Wherein thow {shalt at all tymes Beholde, (privately to thy self) the State of Gods people, through the whole earth.}

II - 1583. April. Hereafter you shall perceyue that the glory of this Table, surmownteth the glory of the 28. after supper Sonne.

[182v]

|   | 1 | 2 | 3 | 4 | 5 | 6 | 7 |
|---|---|---|---|---|---|---|---|
| 1 | B | A | L | I | G | O | N |
| 2 | B | O | R | N | O | G | O |
| 3 | B | a | p | n | i | d | o |
| 4 | B | e | s | g | e | m | e |
| 5 | B | l | u | m | a | p | o |
| 6 | B | m | a | m | g | a | l |
| 7 | B | a | s | l | e | d | f |
| 8 | B | O | B | O | G | E | L |
| 9 | B | E | F | A | F | E | S |

10 B a s m e l o  
11 B e r n o l e  
12 B r a n g l o  
13 B r i s f l i  
14 B n a g o l e

---

15 B A B A L E L  
16 B V T M O N O  
17 B a z p a m a  
18 B l i n t o m  
19 B r a g i o p  
20 B e r m a l e  
21 B o n e f o n

---

22 B Y N E P O R  
23 B L I S D O N  
24 B a l c e o r  
25 B e l m a r a  
26 B e n p a g i  
27 B a r n a f a  
28 B m i l g e s

---

29 B N A S P O L  
30 B R O R G E S  
31 B a s p a l o  
32 B i n o d a b  
33 B a r i g e s  
34 B i n o f o n  
35 B a l d a g o

---

36 B N A P S E N  
37 B R A L G E S  
38 B o r m i l a  
39 B u s c n a b  
40 B m i n p o l  
41 B a r t i r o  
42 B l i i g a n

---

43 B L V M A Z A  
44 B A G E N O L  
45 B a b l i b o

46 B u s d u n a  
 47 B l i n g e f  
 48 B a r f o r t  
 49 B a m n o d e

1 2 3 4 5 6 7  
 [183r]

1588 / 30 / May

|    |     |     |     |     |     |     |     |     |     |     |     |     |
|----|-----|-----|-----|-----|-----|-----|-----|-----|-----|-----|-----|-----|
| 1  | 1   | 2   | 3   | 4   | 5   | 6   | 7   | 8   | 9   | 10  | 11  | 12  |
|    | d   | o   | n   | p   | a   | T   | d   | a   | n   | V   | a   | a   |
| 2  | 13  | 14  | 15  | 16  | 17  | 18  | 19  | 20  | 21  | 22  | 23  | 24  |
|    | o   | l   | o   | a   | G   | e   | o   | o   | b   | a   | u   | a   |
| 3  | 25  | 26  | 27  | 28  | 29  | 30  | 31  | 32  | 33  | 34  | 35  | 36  |
|    | O   | P   | a   | m   | n   | o   | V   | G   | m   | d   | n   | m   |
| 4  | 37  | 38  | 39  | 40  | 41  | 42  | 43  | 44  | 45  | 46  | 47  | 48  |
|    | a   | p   | l   | s   | T   | e   | d   | e   | c   | a   | o   | p   |
| 5  | 49  | 50  | 51  | 52  | 53  | 54  | 55  | 56  | 57  | 58  | 59  | 60  |
|    | s   | e   | m   | i   | o   | o   | n   | A   | m   | l   | o   | x   |
| 6  | 61  | 62  | 63  | 64  | 65  | 66  | 67  | 68  | 69  | 70  | 71  | 72  |
|    | V   | a   | r   | Gs  | St  | tl  | bL  | b   | r   | i   | a   | p   |
| 7  | 73  | 74  | 75  | 76  | 77  | 78  | 79  | 80  | 81  | 82  | 83  | 84  |
|    | o   | i   | P   | t   | e   | a   | a   | p   | D   | o   | c   | e   |
| 8  | 85  | 86  | 87  | 88  | 89  | 90  | 91  | 92  | 93  | 94  | 95  | 96  |
| 9  | 97  | 98  | 99  | 100 | 101 | 102 | 103 | 104 | 105 | 106 | 107 | 108 |
|    | p   | s   | n   | a   | C   | N   | r   | z   | i   | r   | z   | a   |
| 10 | 109 | 110 | 111 | 112 | 113 | 114 | 115 | 116 | 117 | 118 | 119 | 120 |
|    | S   | i   | o   | d   | a   | o   | i   | n   | r   | z   | f   | m   |
| 11 | 121 | 122 | 123 | 124 | 125 | 126 | 127 | 128 | 129 | 130 | 131 | 132 |
|    | d   | a   | l   | t   | t   | d   | n   | a   | d   | i   | r   | e   |
| 12 | 133 | 134 | 135 | 136 | 137 | 138 | 139 | 140 | 141 | 142 | 143 | 144 |
|    | d   | i   | x   | o   | m   | o   | n   | s   | i   | o   | s   | p   |
| 13 | 145 | 146 | 147 | 148 | 149 | 150 | 151 | 152 | 153 | 154 | 155 | 156 |

r g o a n n  C r a r

{There are arrows pointing 'psnacN...' to row 8, 'Siodao...' to row 9, etc. evidently indicating that letters be shifted up one row.}

D: Befafes, nunquam te deserens, docet, puerum breui moriturum, cum aliis tribus; nisi, pro tenus reddantur domino (qui in limine adest,) uota uestra.:

[183v]

[183v is blank]

[184r]

### Bonorum Angelorum Invitationes

Dicen..., tribus  
vicibus, ter,  
tribus vicibus,  
Ter: singulis  
diebus, Donec  
&c.  
..d est .. Tribus,  
singulis diebus.

Ô puyssant and right Noble King, (N,) and by what name els so-euer thow art called, or mayst truely and duely be called: To whose peculier gouernment, charge, disposition, and Kingly Office doth apperteyne, thé (N. &c.)

+ with thy  
Prince, and his  
Ministers and  
subiects, 42

In the Name of the King of Kings, the Lord of Hoasts, the Allmighty GOD, Creator of heaven and earth: and of all things visible and Invisible: Δ COME, now, and appear + to my perfect and Sensible eye Iudgment: in a godly, and frendly manner: to my cumfort, and help, for the auancing of the honor and Glory of our Almighty GOD, by my service: As much as by thy wisdome, and powre, in thy propre\* Kingly office, and government, I may be holpen, and enhabled unto: Amen.

Δ (ô  
ri{ght}  
Nobl{e  
King}  
N.)

\* AR

COME, Ô right Noble King, (N.) I say, COME. Amen.

Gloria Patri, &c.

^+ to be  
aduanced, by my  
faithfull service,  
% (ô O Noble  
Prince, N.)

Ô Noble Prince, (N.) and by what name els, so-euer, thow art called, or mayst truely and duely be called: To whose peculier government, charge, disposition, Office, and Princely Dignitie, doth apperteyne thé, (N, &c.) In the Name of Allmighty God, the King of Kings, and for his honor and glorie ^+, I require thé % to COME presently, and to shew thy self, to my perfect and sensible ey Iudgment, with thy Ministers, seruants and Subiects; to my cumfort, and help, in wisdome, and powre; according to the propertie, of thy Noble Office: COME, ô Noble Prince, (N) I say COME. Amen.

HAG

Pater noster, &c.

[184v]

## SONDAYE:

King  
BOBOGEL

The distributing, giving, and bestowing, of Wisdome and Science: The teaching of true Philosophie, true understanding of all lerning, grownded uppon wisdome, with the Excellencies in Nature, and of many other great Mysteries, mervaylously avaylable, and necessarie to the aduancing of the Glory of our GOD, and Creator. Therefore, In the Name &c.

And saydst to me, (in respect of these Mysteries atteyning), Dee Dee, Dee, At length: But Not to late:

Therefore, In the Name, &c.

Gloria Patri &c.

Prince  
BORNOGO

^ of all lerning  
grownded uppon  
wisdom.

+ And saydst to me  
What Thow desyrest in  
me, shalbe fullfyllid.

[185r]

{Cp. 174r}

The altering of the Corruption of Nature, into perfection: The knowledg of Metalls: and generally the Princely Ministring to the right Noble, and Mighty King BOBOGEL in his gouernment of Distributing, giving and bestowing of Wisdome, science, True Philosophie, and true understanding, ^, and of other very many his peculiar Royall Propreties +. Therefore, In the Name, &c.

Pater noster &c.

## MONDAYE.

King  
CARMARA

-- Who, in this Heptarchicall Doctrine, at blessed Uriel his hand, didst receyue the golden rod of government, and measuring: and the Chayre of Dignity, and Doctrine, and didst appeare first to us, adorned with a Triple Diademe, in a long purple robe: who saydst to me, at Mortlake, I Minister the Strength of God, unto thé.

Likewise thow saydst, These Mysteries hath God lastly and of his great mercies graunted unto thé.

Thow shalt be glutted, yea filled, yea thow shalt swell, and be puffed up, with the perfect knowledg of Gods Mysteries in his mercies.

And saydst, this Art is to the farder understanding of all sciences, that are past, present or yet to come.

And immediately didst say unto me, Kings there are, in Nature, Wyth Nature, and about Nature: Thow art Dignified.

And saidst concerning the use of these Tables, This is but the first step: Neyther shallt thow practise them in vayne.

And sayd thus, Generally, of Gods mercies and graces, on me decreed, and bestowed,

What so euer thou shalt speak, do, or work, shalbe profitable, and acceptable; And the Ende shalbe good:

Therefore, In the Name, &c.

Gloria Patri &c.

**Prince HAGONEL** To whose Commaundement, the Sonnes of men<sup>light</sup>, and their Sonns, are subiect: and are thy Servants. To whose powre, the Operation of the Earth, is subiect. Who art the first of the Twelue; and whose seale is called Barees, and this ☉ it is. At whose commaundement, are the kings, Noble men, and Princis of Nature. Who art Primus, et Quartus Hagonel: Who, by the seuen of the seven, (which are the Sonns of Sempiternitie) dost work mervayles, amongst the people of the eEarth: and hast sayd to me, that I allso, By the same, thy servants, shold work mervayles. Ô Noble Hagonel, who art Minister to the Triple Crowned King CARMARA: and Notwithstanding, art Prince over these 42 Angels: whose Names, and characters, are here presented:

Therefore, In the Name, &c.

Pater noster &c

| <b>Filij lucis</b> | <b>Filij filiorum</b> |
|--------------------|-----------------------|
| I                  | IL.                   |
| Ih                 | An                    |
| Ilr                | Aue                   |
| Dmal               | Liba                  |
| Heeoa              | Rocle                 |
| Beigia             | Hagonel               |
| Stimcul            | Ilemese               |
| In sigillo Æmeth.  |                       |

[185v]

{Cp. 174v}

King  
BLVMAZA

**Prince BRALGES.** -- Who saydst, the Creatures liuing in thy Dominion, are subiect to thy powre: whose subiects are invisible: and which (to my seer) appeared, like little smokes, with out any

forme, Whose seale of gouernment, is this:



Who saydst, Beholde, I am come,

I will teach thé, Names without Numbers. The Creatures subiect unto me, shall be known unto you. Therefore, In the Name, &c.

Pater noster, &c.

[186r]

{Cp. 175v}

**King** -- Who art King in Waters: Mighty and wunderfull in waters: whose Powre is in the bowells of  
**BABALEL** the waters: whose Royall person, with thy Noble Prince BEFAFES, and his 42 Ministers, The Triple Crowned King CARMARA, bad me vse, to the glory, prayse, and honor, of him, which created you all, to the laude and prayse of his Maiestie.

Therefore, In the Name, &c.

**Prince** -- Who art Prince of the seas: Thy powre is vppon the waters: Thow drownedst Pharao: and  
**BEFAFES** hast destroyed the wycked: Thy Name was known to Moyses: Thow liuedst in Israël: Who hast measured the waters: who wast with King Salomon: and also, long after that, with Scotus: but not known to him by thy true name: for he called thé MARES. And since thow wast with none: Except, when thow preservedst me (through the mercy of God,) from the powr of the wicked: and wast with me, in extremities: Thow wast with me throwghly: who of the Ægyptians hast byn called OBELISON, in respect of thy pleasant deliuerance: And by that Name, to me, knowne: and of me Noted in record, to be the Noble and Curteous OBELISON. Whose Noble Ministers 42, are of very great powre, dignitie, and Authoritie: As some in the measuring of the motions of the waters, and saltnes of the seas: in giving good success in Battayles: reducing ships, and all manner of vessells, that fletee vppon the seas: To some, all the fishes, and monsters of the seas, ~~are well known;~~ yea all, that liueth therein, are well known: and generally are the Distributers of Gods Judgments vppon the Waters that couer the earth: Some conduct waters, through the earth: Other do beawtify Nature in her Composition: The rest are distributers and deliuerers of the Threasors, and unknown substances of the Seas: Thow Ô Noble Prince BEFAFES, badst me use thé, In the Name of God. Therefore, In the Name &c.

[186v]

{Cp. 176r}

### WEDDENSDAYE:

**King** -- To whome, the Earth, with her bowells, and secrets whatsoever, are deliuered: and hast sayd to me, heretofore, What thow art, There I may know. Thow art great, but, (as thow truely

BNASPOL didst confess,) He in whome thou art, is greater then thou. Therefore, In the Name, &c.

Prince -- Unto whome, the keys of the Mysteries of the Earth are deliuered: whose 42 Ministers, are  
BLISDON Angels, that govern under thé. All which, thy mighty King BNASPOL bad me use: and affirmed, that they are, and shall be at my Commaundement. Therefore In the Name, &c.

[187r]

{cp. 176v}

### THVRSDAYE:

King -- Upon the distribution and participation of whose exalted most especiall and glorified  
BYNEPOR powre, resteth onely and dependeth the generall state and condition of all things: Whose sanctification glory and renowne, allthough it had begynning, yet can it not, neyther shall haue ending. He that Measureth, sayd, And thou wast the Ende of his workmanship: Thou art like him, and of him: yet, not as partaking, or adherent, but distinct in one degree. When he cam thou wast Magnified by his comming: and art Sanctified, world without ende. Vita Suprema, Vita Superior, Vita Infima, tuis sunt mensurata manibus: Notwithstanding, thou art not of thy self: Neyther is thy powre thine owne: Magnified be his Name. Thou art in all: And all hath some being by thé: yet thy powr is nothing in respect of his powre, which hath sent thé: Thou begynnest New worlds, new people, New Kings, and New knowledg, of a new government: ~~Therefore, In the Name, &c.~~ And hast sayd, to me, Thou shalt work Mervaylous Mervaylously, by my workmanship, in the Highest.

Therefore, In the Name, &c.

Prince -- Who art life and breath in liuing Creatures: All things liue by thé, the Image of One  
BVTMONO excepted; All the kindes of beasts of the earth, dost thou endue with life. Thy seale is their glory. Of God, thou art sanctified: and thou reioycest. The liuing, the ende, and begynning of all beasts, thou knowest, and by sufferance, thou disposest them: untill thy Vyoll be ronne. Therefore, In the Name. &c.

[187v]

{cp. 175r}

### FRIDAYE:

King -- Who canst distribute, and bestow at pleasure, all, and whatsoever can be wrowght in  
BALIGON aereall actions. Who hast the government of thy self perfectly, as a mysterie known unto thy self. Who didst aduertise me of this stone, and holy Receptacle: both nedefull to be had, and allso, didst direct me, to the taking of it up: being presently, and in a few mynutes of tyme, browght to my sight, (from the secret of the depth, where it was hyd, in

the uttermost part of the Roman possession): Which stone thou warnedst me that No mortall hand, but my own, should touch: and saydst unto me: Thou shalt prevayle with it, with Kings and with all Creatures of the world: whose beauty (in vertue) shalbe more worth then the Kingdomes of the erth. For the which purposes, here rehersed, and other, partely now to be practised and enioyed, and partely hereafter, more abundantly, (As the Lord God of hoasts shall dispose) And allso, Bycause, thou thy self art Governour of these 42 thy mighty, faithfull and obedient Ministers: Therefore, In the Name, &c.

A° 1583 Maÿ 5  
Blessed Uriel  
sayd to me A  
Meridie hora 4  
1/2 At Mortlake

Thy Character must haue the names of the fiue Angels (written in the mydst of Sigillum Æmeth) graven vpon the other side in a circle. In the mydst whereof, must the stone be, (which was allso browght). Wherein, Thou shalt, at all tymes, behold (priuately to thy self) the state of Gods people, through the whole Earth.

The stone and  
holy Receptacle.

Prince  
BAGENOL

[188r]

## SATERDAYE

King -- Who hast sayd to me, That by thé I shall cast oute the powre of all wycked spirits: And that  
BNAPSEN by thé I shall, or may know the doings and practises of euyll men: And more then may be spoken or uttred to man: Therefore In the Name: &c.

Prince -- Who, being the Prince, chief Minister, and Gouvernor under thy right puyssant King  
BRORGES: BNAPSEN, didst, (to my seer) appear, in most terrible manner, of fyrie flamyng streams: and saydst, Noui Ianuam mortis. Et percussit gloria Dei Impiorum parietes.

Therefore In the Name, &c.

{finis}



*Anno 1581 : 1582*

*Mysteriórum  
Liber Primus*

*Mortlaci*

+ 1 +



*Præter alias meas extemporaneas preces, et ejaculationes  
ad Deum vehementiores: Hæc una, maxime  
usitata fuit*

*Oratio mea Matutina, Vespertinaque: pro Sapientia.*

*In nomine Dei Patris, Dei Filii, Dei Spiritus Sancti  
Amen.*

*Omnipotens, Sempiterna, vere, et vive Deus, in adjutorium meum  
intende: Domine Dominantium, Rex Regum, Jeovah  
Zebaoth, ad adjuvandum me festina:*

*Gloria Deo, Patri, Filio, et spiritui Sancto: Sicut erat in  
principio, et nunc, et semper et in sæcula sæculorum: Amen.*

*Recte sapere, et intelligere doceto me, (ô rerum omnium Creator,) Nam  
Sapientia tua, totum est, quod volo: Da verbum tuum in ore meo,  
(ô rerum omnium Creator,) et sapientiam tuam in corde meo fige.*

*O Domine Jesu Christe (qui sapientia vera es, æterni et Omnipotentis  
tui Patris) humilimè tuam oro Divinam Majestatem, expeditum  
mihi ut mittere digneris, alicuius pii, sapientis expertique, Philosophi  
auxilium, ad illa plenissimè intelligenda perficiendaque, quæ maximi  
valoris erunt ad tuam laudem et gloriam amplificandam: Et si  
Mortalis nullus iam in terris vivat, qui ad hoc munus aptus sit: vel  
qui ex æterna tua providentia, ad istud mihi præstandum beneficium  
assignatus fuerit: Tunc equidem humilime, ardentissimè et constan-  
tissimè a tua Divina Majestate requiro, ut ad me de cælis mittere  
digneris bonos tuos Spirituales Ministros, Angelosque, videlicet Mi-  
chaëlem, Gabrielem, Raphaëlem ac Urielem: et (ex Divino tuo  
favore) quoscunque, alios, veros, fidelesque tuos Angelos, qui me plene  
et perfecte informant et instruant, in cognitione, intelligentiaque  
vera et exacta, Arcanorum et Magnalium tuorum (Creaturas omnes  
tuas, illarumque naturas, proprietates, et optimos usus, concernentium)  
et nobis Mortalibus scitu necessariorum; ad tui nominis laudem,  
honorem, et gloriam; et ad solidam meam, aliorumque (per me,) plurimorum  
tuorum fidelium consolationem: et ad Inimicorum tuorum confusionem,  
et subversionem. Amen. Fiat Jeovah Zebaoth: Fiat Adonay,  
fiat Elohim. O beata, et superbenedicta Omnipotens  
Trinitas, Concedas mihi (Joanni Dee) petitionem  
hanc, modo tali, qui tibi maximè placebit.  
Amen.*



*Ab anno 1579. hoc ferè modo: Latinè, vel Anglicè; (ast circa annum 1569  
alio et peculiari, particulari modo: interdum pro Raphaële, interdum  
pro Michaële) ad Deum preces fundere: mihi gratissimum fuit:  
Mirabilem in me faciat Deus Misericordiam suum.*

*Amen.*





# John Dee his Note



*Angelus sive In-*  
*telligentia, nunc*  
*toti Mundo prae-*  
*dominens —*

*4. Angeli praesidentes*  
*4. Cardinibus Caeli:*  
*ut Agrippa notat,*  
*in scala Quater-*  
*narii —*

*Etymologiae —*

**MichaelGabrielRaphaelUrie**

∞

*Fortitudo Dei*

*Prevaescentia —*  
*sive praepotentia —*  
*sive Fortitudo } Dei*  
*pravaescens } —*

*Medicina Dei*

*Lux Dei*

**1**

*Etymologia:*  
*Gratiosa } Dei*  
*Afflicta } —*  
*Misericore*

## ANNAEL

⚡⚡ et ⚡⚡

*Anna, et Annah, obsecrantis, et confitentis particula est.*  
*hac ratione, non absurdè innuere videtur,*  
*Orantem et confitentem Deum.*



...] *icensia*  
...] *rique*

*Ad Deum Omnipotentem Protestatio fidelis:  
ad perpetuam rei memoriam Anno 1582.*

O God Almighty, thou knowest, & art my director, and witness herein, That I have from my youth up, desired & prayed unto thee for pure & sound wisdom and understanding of some of thy truths natural and artificial: such, as by which, thy wisdom, goodness & power bestowed in the frame of the word might be brought, in some bountifull measure under the Talent of my capacity, to thy honor & glory, & the benefit of thy Servants, my brethren & Sisters, in, & by thy Christ our Saviour. And for as much as, many yeeres, in many places, far & nere, in many books, & sundry languages, I have sought, & studied; and with sundry men conferred, and with my owne reasonable discourse labored, whereby to fynde or get some ynckling, glyms, or beame of such the forsaid radical truths: But, (to be brief) after all my forsaid endeavor I could fynde no other way, to such true wisdom atteyning, but by thy extraordinary gift: and by no vulgar schole doctrine, or humane Invention. And, Seeing, I have read in thy books, & records, how Enoch enjoyed thy favor and conversation, with Moyses thou wast familiar: And also that to Abraham, Isaac, and Jacob, Josua, Gedeon, Esdras, Daniel, Tobias, and sundry other, thy good Angels were sent, by thy disposition, to instruct them, informe them, help them, yea in worldly and domesticall affaires, yea and sometimes to satisfy theyr desires, doubts & questions of thy Secrets. And furthermore Considering, the Shewstone, which the high preists did use, by thy owne ordering: wherein they had lights and Judgments in theyr great doubts: and considering also that thou (O God) didst not refuse to instruct thy prophets, (then, called Seers) to give true answers to common people of things æconomicall, as Samuel, for Saul seeking for his fathers asses being gon astray: and of other things vulgar true predictions, whereby to wyn credyt unto thy waightier affaires: And thinking with my self, the lack of thy wisdom; to me, to be of more importance, then the value of an Asse or two, could be to Cis, (Saul his father): And remembring what good counsaile thy Apostle James giveth, saying, *Si quis autem vestram indiget sapientia, postulet a Deo, &c.* And that Salomon the wise, did so, even immediately by thy self, attayne to his wonderfull wisdom. Therefore, Seeing I was sufficiently thought and confirmed, that this wisdom could not be come by at mans hand or by humane power, but onely from the (ô God) mediately or immediately) And having allwayes a great regarde & care to beware of the filthy abuse of such as willingly and wetingly, did invoke & consult (in diverse sorts) Spirituall creatures of the damned sort: angels of darknes, forgers & patrons of lies & untruthes: I did fly unto thee by hartly prayer, full oft, & in sundry manners: sometymes crying unto thee, *Mittas lucem tuam et veritatem tuam, que me ducant &c.* sometymes *Recte Sapere et Intelligere doceto me, Nam sapientia tua totum est quod volo: &c.* sometymes, *Da verbum tuum in ore meo, et sapientiam*

*tuam in corde meo fige &c.* And having perceyved by some slight experiens with two diverse persons, that thow hadst a speciall care to give me thy light, and truth, by thy holy and true ministers Angelicall and Spirituall: and at length, hearing of one, (a master of Arts and a preacher of thy word admitted) accownted as a good Seer and skryer of Spirituall apparitions, in Christalline receptacle, or in open ayre, by his practise procured: and trusting to frame him, by my earnest & faithfull prayers unto the (my God) to some my help in my forsayd Studies: tyll, thow (o heavenly father) woldest by thy unsearchable proveydence, send me some apter man or means thereto. Thereuppon trying him and using him, I fownd great diversity betwene his private usuall manner, and intente of practice, and my pure, sincere, devowte, & faithfull prayer unto the onely. And therefore often & fervently I exhorted him to the good; and reproved both him, and his ministers, with my no small danger, but that thow (in manner unherd of) didst pitch thy holy tente to my defence, and cumfert, in conflict most terrible: as thow best knowest o God, and I willed him thereuppon to preach thy mercyes, & the verity of the kingly prophet his testimony, *Castra metatur Angelus Domini, in Circuitu timentium eum.* And out of Roger Bachon his boke written *De mirabili potestate Artis et Naturæ*, (where he writeth against the wycked Divil callers) I noted unto him this sentence, *Facilius (sine comparatione a \*Deo impetrandum foret, vel a bonis spiritibus, quicquid homini utile reputare &c.* Which my cownsayle he promised me to follow, as thow art witnes, o our true & almighty God. And as thy good spirituall creatures neyther had delight in the man, neyther wold so playnely & preistly give me theyr answers or informations by him, that he might be hable to perceyve the pith therof. So was he at length very unwilling to here him self rebuked for his nawghtynes, and to be barred from the Mysteries of thy truthes understanding; which were the onely things that I desyred, through thy grace, o our most mercifull God. Therefore, as well for a Memoriall answerable to the premisses, as for the better warrant of my Such exercises to be made accownt of, hereafter: (leaving all unto thy infinite mercies, and unsearchable providence,) I have thought it not impertinent, to note downe, even in this place one of the last Actions, which I had with the forsayd preacher: When I made earnest & faythfull petition unto the (o the true and Almighty God) for sending, unto my cumfert & erudition, (yf it were thy blessed will,) thy holy, & mighty Angel Annael: of whome and of all the Hierarchies heavenly all prayse honor & thanks, be rendred unto thy divine majestie: now & ever & worlde without ende. *Amen. Amen. Amen.*

\* Numquid non est Deus in Israël, ut eatis ad consulendum Beelzebub, deum Accaron: Reg 4. cap.1.



Anno 1581 Decembris 22. Mane

Mortlak

Δ – After my fervent prayers made to God, for his mercifull cumfort and instruction, throwgh the ministry of his holy and myghty Angel, named Anael, (yf it wer his divine pleasure) I willed, the skryer, (named Saul) to loke into my great Chrystaline Globe, yf God had sent his holy Angel Anael, or no:

### AÑAËL

Δ Note:  
An illuding intruder, even at the first, putting him self, as an angel of light. Take hede allwayes of undue secu= ritie.:

And Saul loking into my forsayd stone, (or Chrystall Globe) for to espie Anael, he saw there <sup>Δ</sup> one, which answered to that name. But being earnestly requested of me to tell the Truthe yf he were Anael, An other did appere very bewtifull, with apparell yellow, glittering, like gold: and his hed had beames like ster beams, blasing, and spredding from it; his eyes fyrie. He wrote in the stone very much in hebrue letters, and the letters seamed all transparent gold: which, Saul was not able eyther presently to reade, that I might write after his voyce, neyther to imitate the letters in short tyme.

A bright star, did go up and down by him.

There appeared allso a white\* dog, with a long hed.

And many other visions appeared, with this second: The first being voyded quite away. Thereuppon I sayd, as followeth,

Δ – *In nomine Jesu Christi, Quis tu es?* — He answered to Saul his hearing.  
AN – *Potestas omnis, in me sita est.*

Δ – *Quæ?*  
AN – *Bona, et mala.*

Δ – Then appeared in the stone, these two letters **M.G.**  
I then axing him some questions, *de Thesauro abscondito*:  
He answered,

AN – *Ne perturbes: Nam hæ sunt Nugæ.*  
And withall appeared many dedd mens skulls,  
on his left hand.

He sayd to me,

AN – *Ubi est potestas tua?*  
Δ – *Cur quæris de potestate aliqua mea?*  
AN – *Cur? Signifi, non mihi placet.*

Δ – I, thereuppon, set by him, the stone in the frame:  
and sayd,

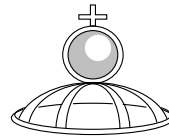

Δ – *An bonus aliquis Angelus, assignatus est huic speculo?*

AN – *Etiam.*

Δ – *Quis?*

AN – **מִיכָאֵל** – he answered, by the shew of these letters in the stone.

Δ – *Bonus ne ille Angelus, de quo in scripturis fit mentio?*

AN – *Maximè.*

Δ – *Fieri ne potest, quod ego eundem videam, et cum illo agam?*

AN – *Ita.* and therewith appeared this character —



Δ – *Quid per hoc, significare velis?*

AN – *Alterius Angeli character est.*

Δ – *Cur hîc, et nunc ostendis?*

AN – *Causam ob magnam.* – Make an ende: It shalbe declared, but not by me.

Δ – By whome then?

Prayer  
Fasting

AN – By him that is assigned to the stone: but not, tyll after the feast. And then thow must prepare thyself, to prayer and fasting.

In the Name of God, be secret: and in all thy doings praying, tyll thow hast thy desyre: which shall not be far of.

After Newyeres tyde, Deale, but not on the Sabaoth day.

Pray contynually.

When it shall pleas god, to stir the up, Then procede. In the brightest day, when the Sonne shyneth: In the morning, fasting, begynne to pray.

In the Sonne Set the stone.

Deale both kneeling, and sitting. I have done for this tyme.

My name is ANNAEL.

I will speak ones more to the: and than fare well: for thow shalt not have me any more.

### Be not to hasty in wrath.

Δ – Is this, that, you ment to speak?

AN – I: Do good to all men. God hath sufficient for the, and for all men.  
Fare well.

Δ – *Gloria patri et filio et spiritui sancto. Sicut erat in principio,  
et nunc et semper: et in sæcula sæculorum.*

*Amen.*

Δ – Remember, that diverse other particulars, mowght have byn Noted of this dayes

Action: but these may suffice: And yet it is not to be forgotten, that as he sayd his name was Annael (with a dubble n) so he allso confessed him self to be the same Annaël which is *prepositus orbis veneris*: and allso Chief governor Generall of this period, as I have Noted in my boke of Famous and rich Discoveries.



Consider and }  
Remember.: } That this Note, of the Action, (had with holy ANNAEL),  
is, of prince Befafes, (otherwise called Obelison) accounted  
as the Prolog of my first boke of mysticall exercises  
*Anno 1582. Novembris 20. — Vide post.*



At Mortlak

*In nomine Jesu CHRISTI. Amen.*

Anno 1582. Martii die. 10. hora 11 $\frac{1}{4}$  Ante Meridiem. Saturday

△  
Note: he had two dayes before made the like demaunde and request unto me: but he went away unsatisfied, for his comming was to entrap me, yf I had had any dealing with



wicked spirits as he confessed often tymes after: and that he was set on, &c.

△ – One Mr. Edward Talbot cam\* to my howse, and he being willing and desyrous to see or shew some thing in spirituall practise, wold have had me to have done some thing therein. And I truely excused myself therein: as not in the, vulgarly accownted Magik, neyther studied, or exercised: But confessed my self, long tyme to have byn desyrous to have help in my philosophical studies through the Cumpany and information of the blessed Angels of God. And there=uppon, I browght furth to him, my stone in the frame, (which was given me of a frende) and I sayd unto him, that I was credibly informed, that to it (after a sort) were answerable *Aliqui Angeli boni*: And also that I was ones willed by a Skryer, to call for the good Angel Anchor, to appere in that stone to my owne sight. And therefore I desyred him to call him: and (yf he wold) Anachor and Anilos likewise, accownted good Angels, for I was not prepared thereunto. *℣c.* He than settled him self to the Action: and on his knees att my desk (setting the stone before him) fell to prayer and entreaty *℣c.* In the mean space, I, in my Oratory did pray, and make motion to god, and his good Creatures for the furduring of this Action. And within one quarter of an howre (or less) he had sight of one in the stone. but he still expected for two more: deeming this to be one of the three (namely Anchor Anachor Anilos). But I then cam to him, to the stone: And after some thanks to God, and Wellcome to the good Creature, used; I required to know his name. And he spake plainly, (to the hearing of E.T.) that his name is URIEL.

△ – Are you one of them (sayd I, John Dee) that are answerable, (uppon due observations performed) to this stone?

URIEL – I am.

△ – Are there any more besyde you?

UR – Michaël and Raphaël. But, *Michaël est princeps in operibus nostris.*

△ – ys my boke, of Soyga, of any excellency?

UR – *Liber ille, erat Adæ in Paradiso revelatus, per Angelos Dei bonos.*

△ – Will you give me any instructions, how I may read those Tables of Soyga?

UR – I can – But *solus Michaël illius libri est interpretator.*

△ – I was told, that after I could read that boke, I shold live but two yeres and a half.

UR – Thow shallt live an Hundred and od yeres.

△ – What may I, or must I do, to have the sight, and presence, of Michael, that blessed angel?

UR – *Præsentialas nostras postulate et invocate, sinceritate et humilitate. Et Anchor, Anachor, et Anilos, non sunt in hunc Lapidem Invocandi.*

△ – Oh, my Great and long desyre hath byn to be hable to read those Tables of Soyga.

UR – *Hæc maximè respiciunt Michaëlem. Michaël est Angelus, qui illuminat gressus tuos. Et hæc revelantur in virtute et veritate non vi.*

△ – Is there any speciall tyme, or howre to be observed, to deale for the enjoying of Michael?

UR – *Omnis hora, est hora nobis.*

△ – After this, there appered <sup>△</sup> in the stone a strange seale, or characterismus of this fashion ensuing:

△:  
An illuding spirit straight way intruded him self, and this character: as may appere *Libri Quinti Appendice* where the character is described exactly.

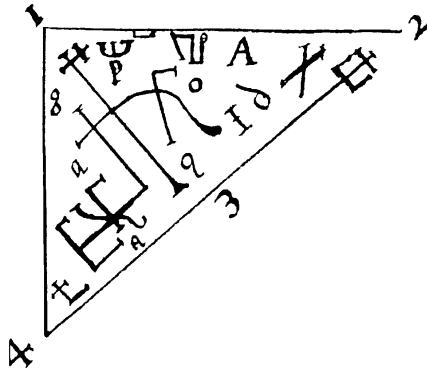

\* This was not True Uriel: as may appere A<sup>o</sup> 1583: May 5.

- Δ – What is the intente, or use of this?  
 \*UR – *Sigillum hoc in auro sculpendum, ad defensionem corporis, omni loco, tempore et occasione: et in pectus gestandum.*  
 Δ – So we ceased, with thanks to god: and I mused much uppon this Action: and layd all up in mynde, and writing.  
 Δ – *Soli Deo Honor omnis, et gloria.*  
*Amen.*



The same Saterday after none. *Hora. 5.*

- Δ – After that Mr. E.T. had called Uriel, and I was come to the stone and had used a short speche of thanks giving to God: I then required some instruction for the purpose of Soysa.  
 UR – Peace. you must use Michaël.  
 Δ – I know no meanes or order to use in the invocating of Michaël.  
 UR – He is to be invocated by certayn of the psalmes of David, and prayers. The which psalmes, are nothing els, but a means unto the seat and Majesty of God: whereby you gather with your selves due powre, to apply your natures to the holy Angels. I mean the psalmes, commonly called the Seven psalmes. You must use pleasant savours: with hand and hart: whereby you shall allure him and wynn him (thorowgh Gods favour) to atteyn unto the thing, you have long sowght for. There must be Conjunction of myndes in prayer, betwyxt you two, to God Contynually.  
 Yt is the wyll of God, that you shold, jointly, have the knowledge of his Angells to\_gither.  
 You had atteyned unto the sight of Michaël, but for the imperfection of Saul.  
 Be of good Cumfort.  
 Δ – The chayre cam into the stone againe: and I axed what it ment.  
 UR – This is a seat of perfection: from the which, things shall be shewed unto the, which thow hast long desyred.  
 Δ – Then was there a square Table browght into the stone: and I demanded, what that Table betokened.  
 UR – A Mysterie, not yet to be known. These two, shall remayn in the stone, to the sight of all undefyled creatures.

Note.  
 Δ in this time there appered in the stone, a riche chayre: and after a little while, it was out of sight.

\*Erronice,  
contra igno-  
rantiam meum  
vide post.

you must use a fowre square Table, two cubits square: Where uppon must be set *Sigillum Divinitatis Dei*, which is allready \*perfected in a boke of thyne: Blessed be God, in all his Mysteries, and Holy in all his works. This seal must not be loked on, without great reverence and devotion. This seale is to be made of perfect wax. I mean, wax, which is clean purified: we have no respect of cullours. This seal must be 9 ynches in diameter: The rowndnes must be 27 ynches, and somewhat more. The Thicknes of it, must be of an ynche and half a quarter, and a figure of a crosse, must be on the back<sub>side</sub> of it, made thus:

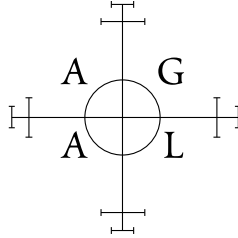

The Table is to be made of swete wood: and to be of two Cubits high with 4 feete: with 4 of the former seales under the 4 feet.

Δ – The fashion of the 4 feet, standing uppon the foresayd rownd seales, was shewed so as the uttermost circle conteyning the letters, did seme to be clean \*without the cumpas of the fete, equally rownd about the same fete. And these seales were shewed much lesser than the principall seal. Under the Table did seme to be layd red sylk, two yardes square. And over the seal, did seme likewise red sylk to lye fowrsquare: somewhat broader then the Table, hanging down with 4 knops or tassells at the 4 corners thereof.

Δ Note this point.

Uppon this uppermost red silk, did seme to be set the stone with the frame: right over, and uppon the principall seal: saving that the sayd Sylk was betwene the one and the other.

The Table was shewed to have on the fowre sides of it, \*Characters and names, these, that are here in a schedule annexed, in 4 diverse rowes.

\*Cave: quia  
angelus tenebra-  
rum se intrusit  
hic ut libri  
Quinti appendice  
apparabit.

UR – The Characters and Words on the sides of the Square Table, are to be written with yellow, made of perfect oyle, used in the church.

Δ – What oyle is that

UR – of That oyle shalbe opened unto you. The oyle, is perfect prayers: of other oyle I have no respect.

We sanctifie, bycause we are holy: and you sanctify bycause of your holines.

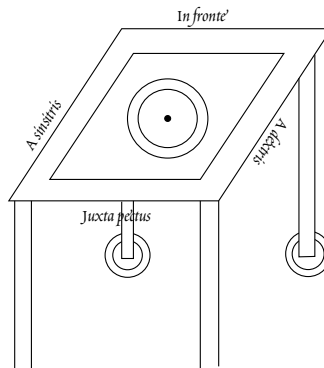

UR – There is a spirit, named Lundrumguffa using you who seketh your destruction, in the hatred of men, in the hurt of thy goods. Discharge him to morrow with Brymstone. He haunteth thy howse, and seketh the destruction of thy dowghter. His pretence was to have maymed the in thy sholder the last night, and long ago. Yf thou do not dischargd him to morrow, he will hurt, both thy wife and thy dowghter. He is here\* now.

Δ Note:  
\* So is it evident who went abowt to hinder the truth before in the character, and in the border of the Table, falsely cownterfeated &c as it also in the next action may appere.

Saul in danger of being carried away quick.

Give him a generall discharge from your familie and howse. He will seke Sauls death, who is accursed.

Δ – I know no means, or art to do this by. For I did burn in flame of Brymstone, Maherion his name and Character, whan I fownd Saul privilie dealing with him (which manner of wicked dealing I had oft forbydden him) and yet he cam after, and wold have carryed Saul away quick: as Robert Hilton, George, and other of my howse can testify.

UR – The cursed will come to the cursed.

Δ – I beseche you to discharge him: and to bynde him somewhere far of, as Raphael did (for Thobias sake) with the wycked spirit Asmodeus.

UR – But Thobias did his part. Art is vayne, in respect of God his powre. Brymstone is a mean.

Δ – Whan shall I do this?

UR – To morrow at the tyme of prayers.

Δ – *Gloria Patri et filio et Spiritui Sancto sicut, &c. Amen.*



1582 Martii 11

Sunday. a Meridie hora .3a. circiter.

Δ – Uriel being called by E.T. there appeared one, clothed with a long robe, of purple: all spanged with gold, and on his hed, a garland, or wreath of gold: his eyes sparkling: of whome I axed Whether the characters noted for the Table, wer perfect:

Δ\* Hereby may appere that this wycked spirit foysted in the shew of the fals characters and names before.

He answered,

They are perfect Δ\*: There is no question.

Δ – Are you Uriel.

Than presently cam in one, and threw the brave spirit down by the sholders: and bet him mightly with a whip: and toke all his robes, and apparell of him: and then he remayned all heary and owggly: and styll the spirit was beaten of him, who cam\_in after him. And that spirit, which so bet him, sayed to the hearing of my skryer, Lo, thus are the wycked skourged.

Δ – Are you Uriel, who speaketh that?

Uri – I am he. Write down and mark this: for it is

Note:  
Lundrum=  
guffa  
skourged  
spiritually.

worthy of the Noting.

This was thy persecutor Lundrumguffa. I browght him hither to let the see, how God hath punished thy enemy.

Lo, thus, hath God delt for the: Lo thus have I delt for the:

Thank God.

Δ – blessed be his holy name; and extolled, world with out ende.

E.T – he drew the wycked spirit away, by the leggs, and threw him into a great pitt, and washed his hands, as it were, with the sweat of his own hed: for he seamed to be all in a sweat.

Δ – Here uppon, my skryer saw Uriel go away: and he remayned out of sight a little while. Then he cam in agayn: and an other with him: and jointly these two said to gither, Glorifie God for ever. And than Uriel did stand behinde: and the other did set down in the chayre, with a sworde in his right hand: all his hed glystring like the sonne. The heare of his hed was long. He had wings: and all his lower parts seamed to be with feathers. He had a roab over his body: and a great light in his left hand. he sayd,

Michaël – We are blessed from the begynning: and blessed be the name of God for ever.

Δ – My skryer saw an innumerable Cumpany of Angels abowt him: And Uriel did lean on the square Table by.

He that sat in the chayre (whom we take to be Michaël) sayd Than,

— Go forward: God hath blessed the.

I will be thy Guyde.

Thow shalt attayne unto thy seching.

The World begynnes with thy doings.

Prayse God.

The Angels under my powre, shall be at thy commanndement.

Lo, I will do thus much for the.

Lo, God will do thus much for the.

Thow shalt see me: and I will be seen of the.

And I will direct thy living and conversation.

Those that sowght thy life, are vanished away.

Put up thy pen.

Δ – So he departed.

Δ – *Gloria, Laus, honor, virtus et Imperium*

*Deo immortalis, invisibili, et*

*Omnipotentis, in sæcula sæculorum.*

*Amen.*

Lundrum=  
guffa.



Martii 14. Wensday. mane circa horam 9a.

- Δ – Being desirous to procede in this matter, by consent, we bent our selves to the Action. And after that [E T] had called Uriel and saw him, I cam to the desk from my oratorie. There did contynually appeare, the chayre and the Table. I than being affrayde that any other shold come into the stone, in stead of Uriel, did earnestly require the spirituall creature appearing, to shew who he was, and what was his name: At length he answered, and sayde to the hearing of E.T., Uriel is my name, with diverse called \*Nariel.

\*Agrippa hath so,  
cap. 24, Lib. 3,  
Occultae Philosophiae

Stay.

- Δ – Then he went away, for a while: and cam agayn, and sayd thus,  
Ur – The strength of God, is allwayes with the.  
Dost thou know, what thou writest?  
Δ – In two senses, I may understand it: eyther that the good Angel ΔGabriel is allwayes with me, thowgh invisibly: or els, that the strength, and mighty hand of God, allwayes is my defense.  
Ur – *Fortitudo Dei, tecum semper est.*  
Δ – He went away agayn, and cam agayn, following or wayting uppon an other: and before that other, was a man having his hed all covered with blak. Then he that cam so in the middle, did sit down in the chayre, and spake this worde following:

Δ -potius erat di-  
cendus Michael:  
Namen, Gabriel est  
Praevalescentia  
Dei: et ita, forti-  
tudo quidem, sed  
altioris gradus.

Mi – Note

- Δ – This was Michael, with his sword in his right hand. Then cam Uriel to the man (having his hed all hyd, as it were in a blak hode) and toke of that blak hode: and then lifted up the Table cloth. He looked under it, and put it down againe: and lifted it up again. The man stode still before Michael. Then Michaël rose, and toke of all the mans clothes, and left him, as it were, onely in his shirt. Then Uriel toke a little rownd Tablet, as it were, of the bignes of a sixpence, having two letters in it, thus:  
and gave it to Michaël.  
Uriel lifted up the Table cloth:  
and, from thence, seamed to take appaiaile, and put on the man. It semed to be sylk: and very full of wrynckles, or plights. And the man kneeled, and held up his hands. Uriel toke like a lawrell bush, and set uppon the mans hed. And than the man kneeled before Michaël. Michaël toke the rownd thing, with the letters: and gave it the man to eat: and he did eat it.  
Ur – Lo, things are covered.  
Δ – Then he covered the Table and pluckt the cloth over it; down to the grownd, on every side. The man rose up: And Michaël dubbed him on the hed with his sworde. Then the man stode up.



Then the man turned his face toward E.T. the skryer: and the man did resemble me (John Dee) in cowntenance. And then he turned to Michaël agayn.

Michael wrote uppon the mans back, thus,

*ANGELVS TVÆ PROFESSIONIS.*

*vide Agrippam  
de Triplici hominis  
custode. Lib.3°.  
cap.22.*

Δ – Then E.T. asked me, yf there were such Angels of a mans Profession: and I answered yea; as in <sup>Δ</sup> Agrippa and other, is declared.

Mi – Leave your folly: Hold thy peace.

Have you not red, that they that cleave unto God, are made like unto him?

Δ – Yes, forsoth.

Mic – Thow camst hither to lern, and not to dispute.

*Laudate Dominum in operibus suis.*

Δ – The man kneled down, and so went out of sight.

Mi – He hath eaten strength against trubble: He hath eaten nothing: and in eating, he hath eaten all things. The name <sup>†</sup> NA, be prayسد in trubbles.

*† vide Reuclimm  
de Verbo Miri  
fico, de nomine  
NA.*

Δ – Now Michael thrust out his right arme, with the sword: and bad the skryer to loke. Then his sword did seame to cleave in two: and a great fyre, flamed out of it, vehemently. Then he toke a ring out of the flame of his sworde: and gave it, to Uriel: and sayd, thus:

Mic – The strength of God, is unspeakable. Praysd be god for ever and ever.

Δ – Then Uriel did make cursy unto him.

Mi – After this sort, must thy ring be: Note it.

Δ – Then he rose, or disapeared, out of the chayre, and by and by, cam agayn, and sayde, as followeth.

Mi – I will reveale the this ring: which was never revealed since the death of Salomon: with whom I was present. I was present with him in strength, and mercy.

Lo, this it is. This is it, wherewith all Miracles, and divine works and wonders were wrowght by Salomon: This is it, which I have revealed unto the. This is it, which Philosophie dreameth of. This is it, which the Angels skarse know. This is it, and blessed be his Name: yea, his Name be blessed for ever.

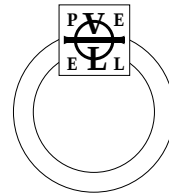

Δ – Then he layd the Ring down uppon the Table: and sayd, Note.

Δ – It shewed to be a Ring of Gold: with a seale graved in it: and had a rownd thing in the myddle of the seale and a thing like an V, through the top of the circle: and an L, in the bottome: and a barr  cleane through it: And had these fowre letters in it, P E L E.

*vide Reuclini  
librum de verbo  
mirifico de  
Nomine PELE.*

After that, he threw the ring on the borde, or Table: and it semed

to fall through the Table and then he sayde, thus,  
Mi – So shall it do, at thy commandment.

Without this, thou shalt do nothing.

The Use of the Ring.

Blessed be his name, that compasseth all things:  
Wonders are in him, and his Name is WONDERFULL:  
His Name worketh wonders from generation, to generation.

Δ – Then he went away: and came in again by and by.

Mi – Note.

Δ – Then he brought in the Seale, which he shewed the other  
day: and opened his sworde, and bad the skryer, reade, and  
he red, EMETH.

*De sigillo Emeth,  
vide Reuclini Artem  
Cabalisticam, lib.3. et  
Agrippam lib. 3.  
Cap.11.*

Then the sword closed up again: and he sayde,  
Mi – This I do open unto the, because thou mervayledst  
at SIGILLUM DEI. This is the Name of the Seale:  
which be blessed for ever. This is the seale self. This is  
Holy: This is pure: This is for ever. Amen.

Δ – Then the seale vanished away. And I sayd to my frende  
(the skryer) In dede, this other day, I considered diverse  
fashions of the seal: and I found them much differing, one  
from an other: and therefore I had neede to know, which of them  
I shall imitate: or how to make one perfect of them all.

Mi – Downt not for the making of it: for God hath perfyted  
all things. Ask not the cause of my absence, nor of my  
apparell: for that Myserie, is known to God. I have no  
cloathing, as thou thy self Shalt see. I am a spirit of  
Truth, and Vertue. Yea you shall see me in Powre,  
and I will visit you in HOPE.

Bless you the Lorde, and follow his wayes, for ever.

Δ – Then he went away: and Uriel followed him.

And then I sayde to my skryer: It were good, we had ever  
some watchword, when we should not looke for any more matters  
at their hands, every tyme of their visitting of us.  
Whereuppon, (unlooked for, of us,) he spake again.

Mi – We lead tyme, Tyme leadeth not us:

Put up thy pen.

The Name of God, be blessed for ever.

Δ – Then they lifted up their hands to heavenward (which heven,  
appeared also in the stone) and turned toward us, and sayd,  
Valete.:

Δ – So they departed: and at their going, the chayr, and the Table,  
in the stone, did seme to shake.

Δ – *Soli Deo omnis honor*

*Laus et Gloria.:*

*Amen.*



*Martii 15. Thursday. Hora 1¼ a meridie.*

Δ – After [E T] his calling into the stone, appeared a tall man, with a sceptre (very great) of gold, glittering. His body all red: and out of his hed, did shote out beames of light, like the sonne beames.

Δ – I being desirous, to know who he was, and his name, I requested him earnestly thereto. But he answered, as followeth,  
*Invocate nomen Domini, et agnoscetis eum.*

Δ – Then I prayed the psalme, *Deus misereatur nostri, et benedicat nobis &c.* After that, he sayd,  
I am mighty.

Δ – Bycause he delayed to declare his name, [E T] the skryer did require him, in the name of God the father, Jesus Christ his sonne, and of the holy ghost, to express his name: and he answered in speche.  
So I will by and by.

Δ – Then he seamed to take from his hed little bright sparcks, like little candells endes: and to stick them abowt the chayre: and he went rownd abowt the chayre: and than he spake, as followeth,

SALAMIAN

Δ - of Salamian you may rede, in the call, *Diei Dominicae in Elementis Magicis Petri de Abano*, there called Salamia.

I am mighty, and working wonders: I am SALAMIAN.

I rule in the hevens, and beare sway uppon erth in his name, who be blessed for ever. Thow doost dowt at me. I am the servant of God, in his light: I serve him. I say, I serve him, with feare and reverence. My name is SALAMIAN: Mighty in the Sonne, worker of wordly actions, as well internall, as externall: known unto God: whose name I know, and bless for ever.

Δ – Then appeared a big flame of fyre by him in the ayre.

Sal – Thow knowest not, or thow wilt not know, that Mamon, with his servants, are present abowt the: whose presence doth hinder the presence of the vertues Adonay our comming. Blessed be God, in the highest.  
Amen.

Δ – He toke the forsaide flame of fyre, and flung it up unto the heaven ward.

Mamon. Sal – Mamon is a king whome God hateth: whose sect, contynually tempt, provoke and stir up wickednes, against the Lord, and against his annoynted. But he dyeth: blessed be God for ever. Drive him away.

Δ – It is incomparably more easy for you to do. And as for my parte, I fele neyther in body, nor sowle, any token of his presence or working. Thereuppon he caused the whole chamber (which we were in) to appere very playnely in the stone: and so there shewed a great cumpany of wycked spirits to be in the chamber: and among them, one, most horrible and grisely thretting, and approaching to our heds: and skorning and gnashing at us.

Sala – God determines his mysteries, by Arte and vertue.

Δ – Then he willed me very egerly, to drive them away. And I prayed fervently. And there seamed One to come into the stone, which had very long armes: and he drave them away courragiously: And so they were driven away.

After that presently, cam one into the stone, all white.

Salamian reached this white one a Cup.

The white man held up the Cup: and sayd, as followeth,

—— Lo, this is my name.

Raphaël

God shall bless you. Fear not: your faithfullness provoketh me to tell my name, and this it is: (putting furth the Cup again) for, I am called Medicina Dei. I will shew the, and I will shew you, the Angel of

De OCH vide in  
libello Arbatel  
in ☉

your Direction, which is called OCH.

Δ – This name he spake: he shewed it allso on the Table (before him) written.

Raph – He is mighty in the sonne beames: He shall profit the hereafter.

Δ – Then cam in an other, and sat down in the chayre: and he sayde, as followeth,

The strength of God liveth: and God raigneth for ever.

I am Fortitudo Dei.

Δ – Why, then, you are Gabriel: and I toke you hitherto to be Michaël.

How shall I then amend my boke, in respect of your name, allwayes before, written Michaël?

[For. Dei] – What thow hast written, that hast thow written: and it is true.

Write down this name. POLIPOS.

Dost thow understand it?

Δ – No, God knoweth.

[For. Dei] – When that day commeth, I will speak with the: yf thow

observe that which I have \*commannded the.

As truely, as I was with SALOMON, so truely will I be with the.

Δ – Then cam in an other, whom we toke to be Uriel: for he went allso, as he was wont, and leaned at the Table.

[For. Dei] – Search for wisdom and lerning, and the lord will deliver it unto you.

Δ – I wold to god, I knew your name truely, or what peculier letter I might set for you, to Note your words and Actions by.

[For. Dei] – Name I have none, but by my office.

SALAMIAN cam not hither, but by me.

He is a mighty Prince, governing the hevens, under my powre.

This is sufficient for thy Instruction.

I was with Salomon, in all his works and wonders:

and so was this, whome God had appointed unto him.

The Divines know his name: and he is not hidden from the face of the erth: His name is written in the boke which lyeth in the wyndow.

Δ – Do you mean Agrippa his boke? And is it there expressed by the name SALAMIAN?

[For. Dei] – I have sayde.

Δ – What order will you appoint unto us two, in respect of our two beings to gither? My frende here, may have other intents and purposes of his affayres, then will serve me, for his ayde having in these Actions.

[For. Dei] – Joyne in prayers. For God hath blessed you: Dowt not. Consider these mysteries.

Δ – Then they in the stone used talk to gither: but not well to be discerned of the eare of [E.T]

At length [F.D] talked very much, and spedily to [E.T] and disclosed unto him (which he expressed not to me, at the stone but afterward) all the manner of the practise, and the circumstance about the Action intended, with the Gold lamin, the ring, the Seales &c. And after I had spoken somewhat, in requesting him, to shew me the manner, How I shold artificially prepare every thing spoken of, he sayd,

[F.D]...

Δ\*  
Perchaunce he  
meaneth the  
cownsayle of  
Annael: before  
specified.

Δ - It is in *Elementis  
Magicis Petri de Abano*  
printed with *Clavis*  
*Agrippae*, which  
was in my oratorie  
almost under my  
wyndow.

[The top third of a page is missing here.]

Write — God will be revenged uppon Saul: for he hath abused his names in his Creatures.  
He hath sinned agaynst kinde. His ponishment is great: and so I ende.

[...] Blessed be God, who revealeth all Mysteries, *et c.*  
I am strength in nede.  
And Lo, here is Medicine for the sore.  
We bless the Lord: We govern the erth, by the societie of Gabriel:  
whose powre, is with us: but he not here. *et c.*  
Use Patience.

Ur – I lived with Esdras: I lived in him, in the lord, who liveth  
for ever.

Raph – I lived with Tobie: Tobie the yonger.

Δ – This was the white creature, that spake this.

**F.D.** – We live in the Lorde: who be prayd for ever.

Δ – I stode silent a good while.

**F.D.** – What wilt thou?

Δ – I did attend, what you wold say.

**F.D.** – I have sayd.

Δ – I have byn long at this tyme, in my dealing with you. I trust,  
I do not offend you therewith. But, for my parte, I could finde in  
my hart to contynue whole dayes and nights in this manner of doing: even  
tyll my body shold be ready to synk down for wearines, before I wold  
give over. But I feare, I have caused wearines to my frende here.

**F.D.** – In vertue is no wearines.

Δ – Now he stode up, out of his chayr: and he, and they all, jointly  
blessed us, stretching theyr hands toward us, Crossingly. And so  
they went away. The Table and the chayre remayned  
and the glyttring sparckles, or drops of streaming little  
lightes were of the chayre immediatly.

Δ – Glorie, thanks, and honor  
be unto the Almighty Trinitie.

*Amen.*





*Mysteriorum  
Liber secundus*



[The top quarter of a page is missing]

...] mysteryes, [...

...] ow toward a thing, r [...

...] howse is hollow, it is empty and voyde [...

...] ants: The God of heven and erth, will send into [...

NOTE. We bring tydings \*of light. The Lord is owr [...  
you and we prayse to gither. His name be prayed for ever O [...  
in his Mysteries: O holy and eternall God.

Δ he bowed down to the Chayre and then to the table, and sayd, *Bene dictus qui venit in*, (and there stayed a little) and sayd agayn, *Bene dictus qui venit in, nomine Domini*.

Δ Than cam in Michaël, with a sword in his hand, as he was wont: and I sayd unto him, are you Michael?

Michael  
Fortitudo  
Dei.

Mich. Dowl not: I am he which rejoyceth in him that rejoyceth in the Fortitude and strength of God.

Δ Is this Forme, for the Great Seale, perfect?

Mi. The forme is true and perfect.

My Oathe  
or vow  
required  
for secrecie

Thow shalt sweare by the Living God, the strength of his Mercy, and his Medicinall vertue, powred into mans sowle never to disclose these Mysteries.

Δ yf No man, by no means, shall perceyve any thing herof, by me, I wold think that I shold not do well.

Mi. Nothing is cut from the Churche of God. We in his Saincts are blessed for ever.

We separate the, from fyled and wycked persons: We move the to God.

Δ I vow, as you require: God be my help, and Gwyde, now and ever, *amen*.

MIC. This is a Mystery, skarse worthy for us ourselves, to know, muche lesse to Reveale. Art thow, then, so Contented?

Δ I am: God be my strength.

Mic. Blessed art thow among the Saincts: And blessed are you both.

Δ  
To E.T.  
he spake.

I will pluck the, from among the wycked [he spake Δ to my skryer.]

Thow Commyttest Idolatry.

But take hede of Temptation:

The Lord hath blessed the. This is a Mystery.

Dee

Dee, what woldest thow have?

Δ *Recte sapere et Intelligere* &c.

Mic. Thy Desyre is graunted the.

Use [...

[The top quarter of a page is missing]

...] with [...]  
...] they are corrupted [...]  
...] They have byn used to the wycked Ther [...]

...] I will shew the in the mighty hand and strength of God, what his Mysteries are: The true Circle of his æternitie Comprehending all vertue: The whole and sacred Trinitie. Oh, holy be he: Oh, holy be he: Oh, holy be he. Uriel answered, *Amen*.

The Circle of Æternitie...

Mic. Now what wilt thou? Δ I wold full fayne procede according to the matter in hand.

**40** Mi. Divide this owtward circle into **40** æquall partes: whose greatest numbers are fowre. See thou do it presently.

Δ I did so. Dividing it first into fowre: and then every of them into ten. He called Semiel, and one cam in and kneled down: and great fyre cam out of his mowth. Michael sayde, To him, are the Mysteries of these Tables known. Michael sayde, Semiel (agayn) and by and by, he said, O God thou hast sayd and thou Livest for ever. Do not think here I spoake to him. Δ he spake that to us, least we might dowte of his last speches, as being spoken to Semiel: which he directed to the æternall god and not to Semiel. Semiel stode up, and flaming fire cam out of his mowth: and than he sayd, as followeth:

Δ Semiel, this etymologie is as though he wer the secretarie, for the Name of God.

The Tables

Sem. Mighty Lord, what woldest thou with the Tables?

Mi. It is the will of God, Thou fatche them hither.

Semiæl

Sem. I, am his Tables. Behold these are his Tables: Lo where they are.

40 White Creatures

Δ There cam in 40 white Creatures, all in white Sylk long robes: and they like chyldern: and all they fallyng on theyr knees sayd, Thou onely art Holy among the highest. O God, Thy Name, be blessed for ever.

Δ Michael stode up out of his chayre, and by and by, all his leggs semed to be like two great pillers of brass: and he as high as half way to the heven. And by and by, his sword was all on fyre and he stroke, or drew his sworde over all theyr **40** heds. The Erth quaked: and the **40** fell down: and Michael called Semiæl, with a thundring voyce, and sayd, Declare the Mysteries of the Living God, our God, of one that liveth for ever.

Sem. I am redy. Δ Michael stroke over them, with

Δ *Semiæl - forte significat Nomen meum Deus. Ita quod Tabulae istae sunt Nomen Dei, vel Nomina Divina.*

his sword agayne: and they all fell down, and Uriel allso unto his knees. And commonly at the striking with his sword, flamyng fyre like lightening did flash with all.

Mi. NOTE: here is a Mysterie.

Δ Then stept furth, one of the **40**, from the rest, and opened his brest, which was covered with Sylk, and there appeared a great **T** all of Gold.

The very fashion of the T was thus: 

Mi. Note the Number. Δ over the **T**, stode the figure of **4**, after this manner: 

The **40**, all, cryed, yt liveth and Multipliyeth for ever: blessed be his name.

Δ T, in the holy language is Gisg vide lib. 5. post et est ultima Alphabeti litera.

Δ That creature did shut up his bosome, and vanished away, like unto a fyre.

Mi. Place that, in the first place. It is the name of the Lorde.

Δ Than there seamed a great clap of thunder to be.

Then stepped (before the rest) one other of the **40**, and kneled as the other did before. And a voyce was herd saying, Prayse God, for his name is reverent.

Michael sayd to me, say after me thus,

*Deus Deus Deus noster, benedictus es nunc et semper: amen.*

*Deus Deus Deus noster, benedictus es nunc et semper: Amen.*

*Deus Deus Deus noster, benedictus es nunc et semper: amen*

Δ Then this Creature opened his breast, and fyre cam oute of the stone as before and a great romayne **G** appeared.

G: dicitur Ged lib. 5.

Mi. Write with reverence, These Mysteries are Wunderfull, the Number of his name, and knowledge.

Lo, this it is, **.9**. Behold, it is but one, and it is Marveyulous.

Δ Then this Creature vanished away.

Mi. The Seale of Gods Mercy: blessed be thy name.

Δ It semed to rayne, as though it had rayned fyre from heven. Then one other of the **40** was browght furth: The rest all fell down and sayd, LO, thus is God known.

N, dicitur, DruX.

Then he opened his brest, and there appered an **n**, (not of so big portion as the other), with the number of **7** over it.

Mi. *Multiplicatum est Nomen tuum in terra.*

Δ Then that man vanished away as it were in a golden smoke.

Mi. Thow must not write these things, but with great devotion.

**He Liveth**. Δ Then cam an other fowrth. Then all falling

down sayde, *Vidimus Gloriam tuam Domine*. They were prostrate on theyr faces. Then this Creature opened his breast

and he had there a Tablet all of Gold (as it were) and there appered a small **t** upon it: and the figure of **9** under this

Δ Gisg.

Letter **t**.

Mi. Mark it, for this is a Mysterie. Δ Then that shewer (of the **40**) seamed to fly up into the ayre, like as it were a white garment.

Mi. *Illius Gloria sit nobiscum*. Δ All sayd, *amen*: and fell down.

Δ Na.

Δ Then stode up an other, and opened his bosom, and shewed on his brest bare (being like sylver) a small **h**; and he pointed to it, and over it was the number of **22**.

Angeli Lucis

Mi. *Et est numerus virtutis benedictus*. Δ This Shewer went away like a White Cok flying up.

Δ Then cam an other in, and sayd,

*Et sum Finis et non est mihi Numerus. Sum Numerus in Numero.*

*Et omnis Numerus est mihi Numerus. Videte.*

Δ DruX.

Δ There appeared a small **n** on his skyn, being all spotted with Gold.

Then he went away like three fyres, red flaming, and coming to gather in the myddst of the firmament. Δ You must Note that in the stone the whole world in manner did seme to appere, heven, and erth, *etc.*

Mi. (Δ he cryed with a lowde voyce) *Et est vita in cælis.*

Δ Then stepped furth one and sayd, *Et ego vivo cum bene viventibus*, and withall he kneeled down: and Michael stepped furth and toke of his veale on his brest and he made Cursy and stode up.

Mi. *Vivamus Halleluyah. O Sanctum Nomen.*

Δ All fell down on theyr faces, and Michael stroke over them with his sword and a great flash of fyre: And this man his brest seemed open that his hart appeared bleading, and therein the letter m, and 6, over it thus 6 m

Δ  
Tal

Mic. *Benedictus est Numerus Agni.*

Δ Hereuppon They all fell down.

Mi. *Orate invicem.* Δ Hereuppon we prayed a psalmé, <sup>my skryer</sup> saying one verse, and I the other *etc.*

Δ  
Med

Mi. *Omnia data sunt a Deo.* Δ – Then cam one in, having a rownd Tablet in his forhed and a little o in his forhed: and 22 over it.

Mi. *Et non est finis in illo.*

*Benedictus es tu Deus.* Δ and then that shewer vanished away: He flew up, like a rownd raynbow knyt together at the endes.

Mi. *Angeli a nomine tuo procident Domine.*

*Tu es primus O Halleluyah.*



Δ One stode up and the rest fell down, and out of his mowth that stode, cam a sworde: and the point, a Triangle, and in the myddest of it a small a thus △, of pure gold, graven very depe:

Δ  
Vn

*Et Numerus tuus vivit in cæleris*, sayd this shewer. The number was 22 over the a.

Corrected thus,  
after, by  
Uriel  
to be 20

This shewer went away with great lightening covering all the world.

Δ  
Drux

Mi. *Nomen illius est nobiscum.* Δ He stroke agayne with his sword over them. Then stode one up: who, uppon his garment had an n: and he turned about: and on his back were very many (ens) n.

Mi. *Creasti tu Domine Angelos tuos ad Gloriam tuam.* Δ Over the n, was the number of 14, over that n (I meane) which was onely on his brest.

Mi. *Et te primus Creavit Deus.* Δ Then the shewer flew up like a star.

Δ  
Vn

And an other cam in, all his cloth being plucked up: and so seamed naked: He hath a little a. This a, did go rownd about him: begynning at his feete: and so spirally upward: and he seemed to be all clay. Over the a, was the number 6.

Note these 3  
parts

Mi. *Et creata sunt et pereunt in Nomine tuo.* Δ and therwith this shewer fell down all into the Earth: and his white garment flew up, like a white smoke: and allso a white thing did fly out of his body.

*Surgit Innocentia ad faciem Dei.*

Δ Michael did over them agayn with his sworde, and it seemed to lighten. He began to speak, and he stopped suddenly, and the fyre flew from his mowth.

Mi. *Innocentium Nomina, et sanguinem vidisti Domine a Terra, et Justus es in operibus tuis.* Δ Then cam one in, with a garment

Δ  
Na



all bluddy. he was like a chylde, he had a ball in his hand of perfume which smoked: and he hath uppon his forhed a little h. He bowed to Michael: and Michael sayd, *Numerus tuus est infinitus, et erit finis rerum.* Δ This shewer seemed to powre him self away

like a flud of blud: and his garment flew upward.

Med †  
|  
| Mi. *Non est illi numerus.*  
†  
|  
| Δ *Omnia pereunt a facie Dei, et a facie Terræ.*  
 Then stepped one furth, and like a water running rownd about him,  
 and he cryeth miserably, O benedictum Nomen tuum Domine.  
*Numerus periit cum illis.* Δ A little o, with **18** over it, appered.  
 Δ This shewer seemed to vanish away, and to cause a great water remayn  
 over all.  
 Mi. *Lux manet in tenebris. Gloriosum est Nomen tuum.*  
 Δ Then stept one furth from the rest, who fell down, as theyr manner was.

Δ Note: All the Cumpanies of these **40**, stode five to gither, and  
 five to gither, and so in eight Cumpanyes; each, of five.

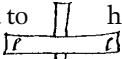
Δ This was a very white one: The upper partes of his throate, seemed open  
 and there seemed to cum out of it fyre, in very many and diverse cullours.  
 he sayd, *Trinus sum.*

Ur Δ  
|  
| Mi. *Benedictum sit nomen EL.*  
 Δ Than in the myddle of the fyres or smoke semed an l, thrise placed,  
 on a bluddy cross, and over the l, the number **26**.  
 Δ This shewer seamed to  have three mens heds and to vanish  
 away in a myst  with a thunder.

Ur Δ  
|  
| Mi. *Labia mea laudant Dominum.*  
 Δ Then cam a very fayre  yong one in with long heare hanging on  
 her (or his) sholders: and on her belly appeared a great scotcheon; to hir,  
 or him, Michael gave a flame of fyre: and she, or he, did eat it.



Ur Δ  
|  
| Mi. *Et hic est EL:* and so appeared a little l, on the scotcheon,  
 and it waxed bigger and bigger: and a fyre did seeme to go rownd  
 about it.

Ur Δ  
|  
| Mi. *Benedicta sit ætas tua:* Δ And there appeared 30, under the l.  
 Δ There cam a great many of little fyers and did seeme to elevate this  
 yong woman (or child) out of sight.  
 Michael stroke his sword over them agayn, and sayd,  
*Natus est illa Lux.*  
*Ille est Lux noster.*

Ur Δ  
|  
| Δ Then stept out an other and opened his white silk garment uppermost: and  
 under it, he seemed to be sowed up in a white silk cloth.  
 He had in his forhed an n, in his brest an n, and in his right hand an n.

Ur Δ  
|  
| Mi. *Numerus tuus est benedictus.* Δ They all fell down, saying,  
*Numerus tuus est Nobiscum: Nec adhuc novimus finem illius*  
*Venies cum numero tuo O unus in æternum.*

Ur Δ  
|  
| Δ and they fell all down agayn. This shewer departed clymyng up into  
the ayre, as if he had clymed on a ladder.

Ur Δ  
|  
| Mi. *Linguis suis cognoverunt eum.*  
 Δ All sayd, *Benedictus est qui sic et sic est*, throwing up into the  
 ayre threornerd trenchers of this fashion  all of Gold. The  
 one side of the trenchers was thus marked, and  the other side had  
 nothing on.

Ur Δ  
|  
| Δ Then stept one oute: and fyre cam out and in of his mowth: he  
 kneeled, the rest fell down. This seemed a transparent body,  
 and he had in his eyes a small l: and in his forhed the figure of **8**.

Ur Δ  
|  
| Mi. Note this, under. I meane the figure **8**. Thus, .

- Δ All sayd, *Et es verus in operibus tuis*: and so he vanished away in a flame of fyre.
- Δ Ged - G Mi. *Gaudete omnes populi eius, gaudete omnes populi eius, ab hinc Gaudete.* Δ – All sayd, *Amen*.
- Δ one stept furth saying, *Incipit virtus nostra*, he being covered under his robe, all with armor: and hath a great **G** on his armor. and the figure of **7**, over it. He went behynde Michael and so vanished away.
- Δ . Note this to be the first that vanished away, going behynde Michael.
- Δ Mi. *Recte vivite omnes Sancti eius.*
- Δ Don One stept furth: and opening his brest, there appered a boke, and turning over the leaves there appeared nothing but a little **r**, and **13** over it. He went behinde the Chayre and so vanished away.
- Δ Mi. *Hic est Angelus Ecclesiæ meæ, qui doceat Ille viam meam.*
- Δ Na There stept oute a playn man, and under his garment a gyrdel, and under his gyrdle a Rod: and in his hand he had a sworde, and in his mowth a flame of fyre: he had a great **H** uppon his sworde and under it **22**. He went behynde the Chayre *∞c*. Michael standing up still uppon his leggs, like pillers of brass. I axed yf I shold not cease now, by reason of the folk tarying for us to come to supper.
- Δ Mic. Lay away the world. Contynue your work: *Coniunxit spiritum mentibus illorum.*
- Δ Then stept out one, having under his garment a little Chest, and therein a mans hart raw: and the hart was thus with two letters, one on the one side **o**, and on the other a **g**: [Δ – As in scotcheons of armes, where the man and his wifes armes ar joyned *per pale*, as the heraulds term it.]  This shewer shut up the chest and went his way.
- Δ Med < ged Mi. *Numerus illius est sine numero.*
- Δ Then cam in an other, saying, *Tempus est. Deus vestrum agnoscite.*
- Δ Gisg Δ This shewer his armes reached down to his feete: he shewed furth his right hand and in it a little **t**, and **11** under it.
- Δ Gon con puncto, y. Δ . *Imago*: I writ first: but, aunciently, and vulgarly both in writing and print, you shall finde *ymago*, though not according to the Latine tung
- Δ Med Mi. *Ymago tua, (mors,) est amara.*
- Δ Then cam one in, with a big belly, and fat cheekes: an half sword perced his hart, and a little **y**, written on it. *Justus est malis deus noster.* Δ The number of **15** under it.
- Δ Mi. Place it in the former place.
- Δ Mi. *Opera fidelium, Delectatio mea.* [Δ Then cam one in.] *Hic est Deus noster.* He shewed the letter of **o** on his naked brest, and the figure of **8** under it. He went away.
- Δ Graph Mi. *Ecce, Iniquitas regnat in domo mea.*
- Δ Then stept one oute very lean, all his body full of little **e**, and under every one of them, **21**. He went away behynde the chayre.
- Δ Pa - b Mi. *Bestia devoravit populum meum, peribit autem in æternum.*
- Δ Then stept out one in bluddy apparell, all his body full of serpents heds and a **b** on his forhed, and the number of **10** over it . He went away.
- Δ Mi. *Iniquitas Abundat in templo meo, et sancti vivunt cum Iniquis.*
- Δ – One very lean, hunger sterved cam out, an **A** on his brest, and **11**, over it,

Δ I think }  
it be }+ Δ  
superfluous }

and so went away.

There cam in an other.

Mi. *Iniqua est Terra malitiis suis.*

Δ Then cam in one who drew out a bluddy sworde, on his brest a great romayn I, and 15 over it. he went his way.

Mi. *Angeli eius ministraverunt sanctis.* Δ Then stept one oute with a Target and a little a on it, and over it the number of 8. He went away.

Mi. *Regnabit Iniquitas pro tempore.* Δ They all cryed Halleluyah.

Δ Then stept one furth with a golden crown, and a great arming sworde: his clothing all of gold, with a letter r on his sword and 16 over it, and so he went away.

Δ  
Uriel  
corrected  
it after,  
to be under

Mi. *Nulla regnat virtus super terram.* Δ Then stept one oute, having all his body under his white sylken habit (as they all, had) very brave after the fashion of those dayes, with great ruffs, cut hose, a great bellyed dubbet, a velvet hat on his hed, with a feather: and he advanced him self braggingly: He had burnt into his forhed a little n: and Michael sayd, *Non est numerus illius in Cælis.* Δ He went away.

Mi. *Antiquus serpens extulit caput suum devorans Innocentes. Halleluyah.*

Δ Then cam one who put of his white habit: and he toke a sword, and smote up into the ayre, and it thundred: and he had a seal (suddenly there) very gorgeous of gold and precious stones. he sayd,

*Regnum meum: Quis Contradicet?*

Δ He hath proceeding out of his mowth, many little (enns) n, and on his forhed, a great A.

Mi. *Non quòd est A, sed quòd contradicit A.  
Nec portio, nec numerus eius invenitur in cælo.  
Habet autem Numerum terrestrem*

*Mysterium*

Mysterium  
nobis reve=  
landum

Δ He shewed three figures of 6, set in triangle thus, 6<sup>6</sup>6

Mi. *Vobis est Mysterium hoc, posterius revelandum.*

Δ And there cam a fyre and consumed him, and his chayre away, suddenly.

Δ My skry=  
er had omit=  
ted to tell  
me this, or  
els, it was  
not told  
and shewed,  
but Uri=  
el did after  
supply it  
by the  
skryer  
The first  
letter of  
Perturba=  
tur, doth  
not make  
shew, of  
the letter  
following  
as other  
before  
did.

Mi. *Perturbatur terra iniquitate sua.*

This shewer, his garments, white, under: his face as brass: his body gre=  
vous with leprosy: having uppon his brest an O, with the number of  
.10. under it: and so he departed.

Mi. *Surgite O Ministri Dei. Surgite (inquam) Pugnate: No=  
men Dei est æternum.*

Δ Then cam two oute to gither: they had two edged swords in theyr hands, and fyre cam oute of theyr mowthes. One had a G, and 5 over it, the other had...

[Δ – We fell to prayer, whereuppon Michael blessed us.]

The other had an h on his sword, and 14 under it: and so they went away.

Mi. *Omnis terra tremet ad vocem tubæ illius.*

Δ One stept out, and under his habit had a trumpet. he put it to his mowth, and blew it not. On his forhed a little o, and 17 under it. He went away.

Mi. *Serva Deus populum tuum, Serva Deus populum tuum Israel, Ser=  
va (inquam) Deus populum tuum Israel.* Δ He cryed this, alowde.

Δ  
Fam

Δ One appeared with a fyry sword, all bluddy, his vesture all bluddy his vesture all bluddy, and he had s.

*Est numerus in numero.* Δ He went away.

Δ I understand it to be a letter, and the number 5 also. Mi. So it is.

Δ  
Uriel also  
did correct  
this place  
with delive  
ring this  
in the  
place of  
the other des  
cription  
before.

Δ There cam one in with diverse owgly faces, and all his body skabbed.  
Mi. *Nunc sunt Dies tribulationis:* Δ He had an a on his  
forhed and the Number 5 under it.  
Mi. *hic est Numerus predictus.*

Mi. *Audite, consummatum est.* Δ This had a great pot of water  
in his hand and uppon the pot, graven, a with 5 under it. He  
departed in fyre.

Mi. *Angele preparato Tubam tuam.*

Δ Then cam one oute with a Trumpet. *Venit Tempus.*

Δ He offered to blow, but blew it not. on the ende of his Trumpet  
was a little a and 24 under it. he went away.

Δ They all now seemed to be gon: Michael and all.  
He cam in agayn and two with him. And he sayd, *Hii duo*  
*Cælati sunt adhuc.* They two went away.

Mi. *Vale. Natura habet terminum suum.*

Δ He blessed us and florished his sword towards, and over us,  
and so went away and Uriel after him: who all this while  
appeared not.

Δ After supper Mr. Talbot went up to his chamber to prayers: and  
Uriel shewed himself unto him: and told him that somewhat  
was amysse, in the Table or seale which I had  
byn occupied abowt this day. And thereuppon, Mr. Talbot cam  
to me into my study: and requyred the seale (or Tables) of  
me: for he was wished to correct something therin, (sayd he)  
I delivered him the seal, and he brougth it agayn within  
a little tyme after, corrected: both in the numbers, for quantyty  
and some for place over or under; and allso in one letter or  
place omitted. Which I denied, of any place omitted by me,  
that was expressed unto me. And the rather I dowted, uppon  
Michael his words last spoken, uppon two places then remay=  
ning yet empty: saying, *Hii duo Cælati sunt adhuc.* But  
If I had omitted any, there shold more than two have wanted.  
Whereuppon we thought good to ax Judgment and dissolving  
of this dowte, by Michael. And comming to the Stone  
He was redy: I prepownded this former Dowte. He answered,

Mi. *Veritas est sola in DEO. Et hæc omnia vera sunt.*

The  
Descryer, or  
The Skryer  
omitted to  
tell.

you omitted no letter or history that was told you. But the  
skryer omitted to declare unto you. Δ May I thus recorde it?  
Yt is justly reformed by Uriel: the one being omitted of the descrier  
and the other not yet by us declared, might make that phrase  
meete to be spoken, *Hii duo cælati sunt adhuc.*

Mi. Thow hast sayd. Δ I pray you to make-up that one  
place yet wanting. Then he stode up on his great brasen leggs  
agayn: He called agayn, Semiæl Semiæl. Then he cam,  
and kneled down.

*Consummatum est.* Δ The shewer (a white man) pluckt

oute a trumpet, and put it to his mowth, as though he wold blow, but blew not: and there appeared at the ende of the Trumpet the greke ω. There arose a myst, and an horrible Thunder.

Mi. It is done. Δ Then of the three <sup>6</sup>6 before Noted, with his finger he put oute the two lowermost: and sayd, *Iste est numerus suus*. And Michael did put his finger into the trumpets ende, and pulled furth a rownd plate of Gold, wheron was the figure of .1. with many circles about it, and sayd *Omnia unum est*.

Δ The forme of the world which appered before, vanished away: and Se myeil went away. And Michael cam and sat in his chayr agayn:

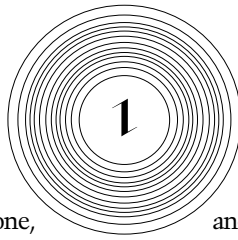

Mi. and his brasen leggs wer gone, and uppon our pawsing he sayd, Go forward. Do you know what you have allready written? *Laudate Dominum in Sanctus eius*.

Note: The Circumference (which is done) conteyneth 7 names: 7 names, conteyn 7 Angels: Every letter, conteyneth 7 Angels: The numbers are applyed to the letters. Whan thou dost know the 7 names, thou shalt understand the 7 Angells.

The Number of 4, pertayning to the first T, is a Number significative: signifying, to what place thou shalt next apply the eye: and being placed above, it sheweth removing toward the right hand: Taking the figure for the number of the place applyable to the next letter to be taken. The under number, is significative: declaring, to what place thou shalt apply the next letter in the Circumference, toward the left hand. Which thou must reade, untill it light uppon a letter, without number, not signifying. This is the Whole. So shalt thou fynde the 7 principall Names: known with us, and applyable to thy practise.

Make experience.

Δ Then telling from <sup>4</sup>T, 4 more places (toward the right hand) exclusively, I finde in that fowrth place, from ,T, (but being the fifth from the beginning, and with the beginning) this letter **h**: with **22**, over it. Therefore, I procede to the right hand, 22 places: and there I finde **A**, and **11** over it. Going then toward the right hand 11 places furder: I finde a little **a** with **5** under it: by reason of which under place of 5, I go toward the left hand, 5 places, exclusively; where I finde **o** with **10**, under it: wheruppon I procede to the left hand, farder by 10 places, and there I see the letter **t**, and **11**, under it: and therefore going to the left hand 11 places, I see there the letter **h** alone without any number. Wherefore, that letter, endeth my word, and it is in all, **ThAaoth**: Ys this, as it shold be?

Mi. That is not the name. Thow shalt understand all in the next Call. The Rule is perfect. Call agayn within an howre

Δ Note these doings to be accounted Calls

Semi Ell

The decla-  
ration of  
the Num-  
bers

Calls

and it shalbe shewed.

Δ The howre being come we attended Michael his return to make the Practise evydent of his first Rule.

Mi. *Salvete.*

Thow diddest erre: and herein hast thow erred: and yet notwithstanding no error in the, bycause thow knowest not the error.

Understand that the 7 Names must comprehend, as many letters in the whole, as there are places in the circle: Some letters are significative of them selves. In dede no letters, but dubble numbers, being the Name of God. Thow hast erred in the first

Dubble Numbers



Note

Δ Note: 7 names, proceeding from 3 generall places of the Circumference or 3 generall letters, being but one letter and that, Δ.

name, in setting downe **Aa**; that is, twice **a** together, which differ the word. Which thow shalt Note to the ende of thy work: Where soever thow shalt finde two a a together the first is not to be placed within the Name, but rather left with

his inward power. Thow shalt fynde 7 Names proceeding from three generall partes of the Circumference: My meaning is, from three generall letters: and onely but one letter, that is, this letter **A**. Account thow, and thow shalt finde the names just. I speak not of any that come in the beginning of the word but such as light in the myddest: Prove; Prove: and thow shalt see. Whereas thow hast **go**, it is to be red **og**. This is the whole.

Δ – I have red in Cabala of the Name of God of 42 letters: but not yet of any, of 40 letters: That of 42 letters is this,

אב אלהים בן אלהים רוח הקדש אלהים  
שלשה באחד אחד בשלשה

*id est: Pater Deus, Filius Deus, spiritus sanctus Deus: Tres in uno, et unus in tribus. Vel Trinitas in unitate et unitas in Trinitate.*

Δ vide Galatinum, lib. 3. cap. 11

Or thus, אב אל בן אל רוח הקדש אל אכל לא שלשה  
אלהים כי אמ אלוה אחד

which in Latin is, *Pater Deus, Filius Deus, et Spiritus Sanctus, Deus, attamen non tres dii sed unus Deus.*

And as this is of God, Unitie in Trinitie, so of Christ onely (the second persone of the Divine Trinitie) the cabalists have a name explained of 42 letters, on this manner,

כאשר הנפש המשכלת והבשר אדם אחד  
בן האל והאדם משיח אחד

That is in Latine, *Sicut anima rationalis, et caro, homo unus, ita Deus et homo, Messias unus.*

I am not good in the hebrue tung, but, you know my meaning.

Mi – The letters being so taken oute, being a name, and a number, doth certefye the old rule of 42 letters, when you restore them in agayn.

Δ 42, are here in potentia, but, non Actu

The Vertu of this Circle



Mi – Note, Oute of this Circle shall no creature pass, that entreteth, yf it be made uppon the earth. My meaning is, if he be defyled: This shalt thow prove to be a mysterie unknown to man.

ADAMS  
TREA=  
TISE,  
Δ He mea  
neth my  
Booke that  
I call  
Soyga

Beasts, birds, fowle and fish do all reverence to it: In this they were all created. In this, is all things conteyned. In tyme thou shalt finde it, in ADAMS Treatise from Paradise. Looke to the Mysteries: for they are true.

*A and ω: Primus et Novissimus; unus solus Deus vivit nunc et semper: Hic est, et hic erit: Et hīc, sunt Nomina sua Divina.*

*Dixi:*

Thow art watcht all this night: who is even now at the Dore: Clerkson.

Blessed are those, whose portion is not with the wicked.

*Benedicamus Dominum. Halleluyah.*



Tuesday the 20 of Marche: *circa 10<sup>a</sup> mane.* // ers to them.

Δ Are you Uriel?

Ur. I am. We thank the for thy great good will.

/ and corrected certayn pray=  
Δ. I had made, and written, ^

We cannot vset the now. At the twelfth howre thou shalt use us.

Δ *Fiat voluntas Dei.*

*A meridie circa 2a*

Δ At the twelfth howre, my partner was busyed in other affayres, and so contynued tyll abowt 2 of the Clok: when; we comming to the stone, fownd there Michael and Uriel: but Michael straight way rose up and went out, and cam in agayn, and one after him, carrying on his right shulder, 7 little baskets, of gold they seamed to be.

Baskets

Shut } Mi. Shut up your doores. Δ I had left the uttermore dore  
Dores } of my study, open: and did but shitt the portall dore of it.

Δ He toke the 7 Baskets, and hanged them rownd abowt the border of a Canapie, of beaten gold, as it were.

Mi. *Ecce, Mysterium est. Benedictus Dominus Deus Israel.*

Δ Therewith he did spred oute, or stretch the Canapy : Whereby it seamed to cover all the World [which seamed to be in the stone allso, heven, an erth] so that the skryer could not now see the heven. And the baskets, by equall distances, did seeme to hang in the border of the horizon

Mi. What wold you have Δ *Sapientiam*

Mi. Rede the names thou hast written. Δ I had written these according to the Rule before given, as I understode it.

**Th<sup>h</sup>aoth**

**Gal<sup>h</sup>as**

**Gethog**

**Horlōn**

**Innon**

**A<sup>h</sup>oth**

**Galets.og**

Mi. Loke to the last name. Δ I had written (as appeareth) **Galetsog**

by misrecke[n]ing the numbers. Where I fownd it shold be **Galethog** with an **h** and not **s**.

Mi. Lo, els thow hadst erred. They are all right, but not in order  
The second is the first (his name be honored for ever) The first here, must be our third and the third here, must be our second : thus set downe.

- .1. Galas.
- .2. Gethog.
- .3. Thaoth.
- .4. Horlon.
- .5. Innon.
- .6. Aaoth.
- .7. Galethog.

Mi. Work from the right, toward the left, in the first angle next unto the circumference

Δ He shewed than, thus, this letter 

M. Make the number of 5 on the right hand, (that is, before it) at a reasonable distance, thus  5

Δ After that, he shewed the second letter, a great roman A, thus,  24

Then he shewed  30

Then —  21

Then —  9

Then he shewed  14

Then he shewed this compownd letter, with the circle and cross 

He willed me, at each corner of these segments of circles, to make little Crosses and so I did.

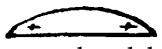
Δ After every of the 7 letters shewed he did put them up in his bosom assone as he had shewed them fully. The plates wheron those letters were shewed, hath the forme of the segment of a circle, thus  : and seemed to be of pure gold. When the 7 letters were placed, he sayd

*Omnia unum est.*

Then he pulled all the 7 plates out of his bosom and Uriel kneeled down before him. Then the plates did seeme to have two wings (eche of them) and to fly up to heven under the Canapye.

Δ After this, one of the 7 baskets, ( that which is in the east ) cam to Michael. and he sayd.

Mi. Seal this. For this was and is for ever

Δ Then he stode agayn on his leggs like brasen pillers, and sayd

Mi. Oh how mighty is the name of God, Which rayneth in the heavens O God of the faithfull, for thow raynest for ever.

Δ he opened the basket, and there cam a great fyre out of it.

Δ-  
Note of  
7 Baskets

**1.**

- Mi. Divide the 7 partes of the circle next unto that which thow hast done, every one, into 7.  
Note: (for the tyme will be long:) Seven, rest in 7: and the 7, live by 7: The 7, govern the 7. And by 7, all Govern=ment is. Blessed be he: yea blessed be the Lord: prayed be our god: His Name be magnified: All honor and Glory be unto him now and for ever. *Amen.*
- Δ Then he toke oute of the fire in the basket, a white fowle like a pigeon That fowle had a **Z** uppon the first of 7 feathers which were on his brest . that first feather was on the left side
- Mi. Note. there is a mysterie in the Seven. which are the 7 governing the 7 which 7 govern the earth. Halleluyah.
- Mi. Write the letters; Δ Now, a small **I** in the second fether. Then he covered those first two letters, with the other feathers The third an **I**, like the other: then he covered that allso. the fowrth an **R** he covereth that the fifth a great roman **H.** he covereth it. the sixth feather hath a little **i** . then he hid that feather, the last feather had a small **a**.

Mi – Prayse god.

Δ Then he put the fowle into the basket – and set it down by him. Then he hong it up in the ayre by him.

Δ Then he lift up his sworde over us, and bad us pray. Δ We prayed.

**2.**

Δ Then he stretched out his hand and there cam an other basket to him. and he pluckt out a White byrd, much bigger than the other: as big as a swan: with .7. feathers on the brest

Mi – *Dixit, et factum est*

Mi. Note: Δ – the first feather hath a little **a**, on it: and it went away: the next a **Z** great as the first

Then a **C** great

Then a little **a**

Then an other little **a**

Then a feather with a little **c**

Then one with a little **b** Δ Then he covered them all.

Mi – Thow hast truth.

Δ Then he put up the fowle into the basket; and hung it up by the other in the ayre

Δ Than the third Basket cam to him, and he toke out a byrd all green as grass. Like to a peacock in form and bignes

Mi. *Et vivis tu cum illo: et*

*regnum tuum cum illis est*

Δ There started out of this birds brest, 7 fethers, like gold, and fyrie

Mi. Pray.

**3.**

Mi. Note. Δ on the first feather a small **p**

Then a small **a**

a little **u**

Then a small **p**

Then a small **n**

then a small **h**

Then a small **r**. Then he put the fowle up into the Basket, *∅c.*

Δ Then there cam an other basket to his hand.  
 Mi. *Dedit illi potestatem in cælis.*  
*Potestas illius magna est.*  
*Orate.* Δ – We prayed.

4. Δ Then he pluckt out a fowle, greater than any of the other, like a griphen (as commonly they are figured) all red fyry, with skales like brass. Then on the seven skales, appered letters.

Mi. Note. Δ – first a little **h**  
 a little **d**  
 a little **m**  
 Then a little **h**  
 Then a little **i**  
 Then a little **a**  
 Then a little **i**

Δ then he put up the fowle, & hung the basket in the Ayre.

Δ Then there cam an other basket to him.

[Δ Note: all this while the firmament was not to be seen.]

Mi. *Magnus est DEUS in Angelis suis.*  
*et magna est Ilorum potestas in Cælis.*

*Orate.* Δ We prayed.

5. Δ Then he pluckt out a bird like an Egle: all his body like Gold and he had a little circle of feathers on his brest: and on it, between fowre parallell lines, twelve equall squares: and on the top, on the myddle, one, like the other twelve, thus.

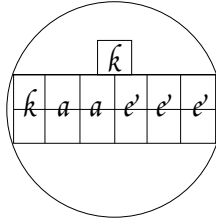

Δ Then he put up the Egle, *etc.*

Δ Then cam an other Basket.

Mi. *Nuncius tuus est magnus in cælis.*

*Orate.*

Δ He, and the Basket that wer opened, shut, and set aside, seamed all to be gon. and the Baskets remaying still hanging on the border of the Canapie. Then he cam agayn, and went awaye agayne. Then cam URIEL and held the Basket: and his leggs seemed to be such great tall pillers of Brass. as Michael did stand on before.

Δ. Michal was the sixth name *vide post*

UR. This is a Mysterie. He is here, and not here which was here before.

6. Δ He opened the Basket and pluckt out like a phenix [Δ or pelican] of the bignes of a swan, all fyrie sparkling. His byll is bent into his brest and it bled. In his brest was a quadrangle made with his own feathers, thus. He put it up, and hung it by the other Baskets.

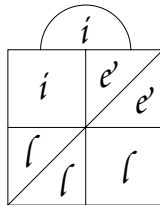

Then cam the last basket. Uriel stode still and sayde:  
 UR. *Dedit angelis potestatem in lumine cæli.*  
*Orate.* Δ We prayed.

7 Δ Then cam Michael, and toke the Basket of Uriel and becam standing  
 on the great brasen legs, as before.  
 Δ He toke out of the basket a strange fowle with many wings:  
 This fowle had in his forhed a Tablet of this fashion

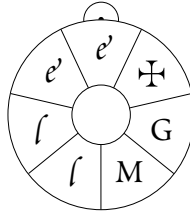

Mi. *Et Coniunxit illos DEUS in Unum.*

Δ All the Baskets flew up: and so the Canapie vanished away: and the Heaven appeared.

Δ Now he cam and sat down in his chayre.

Uriel. Δ Michael sayd to Uriel: it is thy part, to expownd these Mysteries: Go to, in the name, of our God.

Δ Uriel cam and stode before him and sayde: What will you: Ô our fellows, and servants to GOD? What will you?

My contynuall  
and auncient  
prayer

Δ Perfect Knowledge, and understanding, such as is necessary for us.

UR. Looke uppon, and see if thou canst not understand it: We will depart for a little space: and come to the agayne.

Δ So they went: and left all the stone on fyre, so that neyther the Chayr or Table could be seen in it.

Δ After a quarter of an howre, Michael and Uriel cam both agayne.

Mi. Loke into the 7 angles next unto the uppermost Circumference.

Δ Uriel cam and stode before Michael.

UR. Those 7 letters, are the 7 Seats of the One and everlasting GOD. His 7 secret Angels proceeding from every letter

Δ Note these manifold and great Mysteries and mark these 7 diverse crosses with these 7 letters.

and Cross so formed: referred in substance to the FATHER: in forme, to the SONNE: and Inwardly to the HOLI GHOSTE. Loke uppon it: it is one of the Names, which thou hast before. every letter conteyning an Angel of brightnes: comprehending the 7 inward powres of God; known to none, but him self: a sufficient BOND to urge all Creatures to life or Death, or any thing els conteyned in this world. Yt banisheth the wicked, expelleth evyll spirits: qualifieth the Waters, strengtheneth the Just, exalteth the righteous, and destroyeth the wicked. He is ONE in SEVEN; He is twice THREE.

Note this Bond.

Δ - He is twice three and one

He is Seven in the Whole. He is Almighty. His Name is everlasting. His Truth can not fayle. His Glory is incomprehensible. Blessed be his name. Blessed be thou, (our GOD) for ever.

UR. | Thow must refer thy numbers therin conteyned, to the Upper Circle. For, From thence, all things in the inward partes, shalbe comprehended.

Looke if thou understand it

Δ I find it to be **GALETHOG**;

UR. it is so. Δ – I thank God and you, I understand now (allso) the numbers annexed.



Ur. As this darkness is lightened, by the spirit of God, herein; So will I lighten, yea so will the Lord lighten your Imperfections, and glorifie your myndes to the sight of innumerable most holy and unspeakable Mysteries.

Ur. To the next part. Δ Michael sat still, with his sword in his hand.

7 Angels.

Ur. The parte wherein thou hast labored, conteyneth 7 Angels. Dost thou understand it? Δ – Not yet: Ur. Oh how far is mans Judgment from the Celestiall powres? Oh how far are these secrets hidden from the wycked? Glory be unto him; which seeth for ever. Δ – *Amen, Amen, Amen.*

Ur. Note. We can not tary long.

Thow must set down these letters onely, by 7, in a spare paper: thus.

Δ I have hitherto forgotten to ax wher Uriel his name may appere.

UR. Rede \_\_\_\_\_ Begyn at the first, and rede downward. Δ I rede thus, **Zaphkiel,**

**Zadkiel, Cumael**      *a z c a a c b*      **Raphael, Haniel, Mi=**

**chaël, Gabriel,**      *p a u p n h r*      Ur. Thow hast red right

Δ – prayed be God.      *h d m h i a i*      Ur. Thus dost thou see, how

mercifully God dea=      *k k a a e' e' e'*      leth with his servants.

*i i e' e' l l l*  
*e' e' l l M G †*

Every letter here, conteyneth or comprehendeth the number of 72

Vertues. Whose names thou shalt know: skarse yet revealed to the world.

Uriel and Michael jointly together prononced this blessing on us.

UR. } We bless you: your { sowles  
Mi. } { Harts  
          { Bodyes  
          { and all your doings.



Δ Innumerable multitudes of Angels]

Δ Michael with his sword, and flame of fyre florished over our heds.

Yet I will thus much show you, for your cumfort beside. What

seest thou? Δ – he spake to the skryer. and he saw an innumerable multitude of Angels in the chamber or study

about us, very bewtiful with wyngs of fyre. Then he sayd,

Lo, thus you shalbe shaddowed from the wicked. Kepe these

Tables secret. He is secret that liveth for ever.

Man is frayle.      Fare well.

He must

( Δ – of this sentence cam no frute nor farder confirmation. Therefore consider.)

The L.  
Mowntegles  
bokes

go for the bokes, els they will perish. Δ – He ment that my partner Ed. Talbot, shold go to fatch the bokes from Lancaster (or therby) which were the Lord. Mowntegles bokes, which Mr. Mort yet hath: wherof mention is made before.

ended *hora. 5. a meridie*

Tuesday the 20 *Martii*

1582



Wensday. 21. *Martii*, *circa 2. a meridie*

Note this  
Trumpeter Δ

After appearance was had, there cam in one before Michael ( who sat in his seat ) and Uriel leaned on the table (as he, usually did). This seemed to be a trumpeter: he was all in white, and his garments bespotted with blud. he had nothing on his hed. his heare very long hanging behynde him on his sholders. The Trumpet seamed to be gold. The sownd therof was very playne.

We were  
commanded  
not to ax  
of the appa  
rayle of  
Michael. Δ

I axed of my skryer, in what manner Uriel now shewed, (and Michael likewise.) Then Michael said, I warned the for axing of my apparell or manner. *Et hæc est Gloria illius, quæ non commovebitur ab impiis.*

Mi. *Quid vultis? Δ – Juxta voluntatem Dei, Sapientiam nobis necessariam ꝑc.*

Mi. *Sapientia mundi, nihil est, peribit autem in æternum. Veniat æternitas DOMINI, ab universis mundi partibus.*

Phanaël

*Venite, venite, sic vult DEUS ADONAY fac officium Phanaël.*

Δ This Phanaël was the Trumpeter, (above mentioned ) who thereupon blew his Trumpet, Lustily, turning him self rownd abowt, to all the world. Then, from 7 partes of the world, ( being equally divided abowt the Horizon,) cam 7 Cumpanyes of Pillers all of fyrye cullour glittering. And every Cumpany of Pillers high and great and as though they were Pillers of fyre. The Heaven, the Sonne, and, Mone and Sterrs seemed to tremble.

Mi – *Multiplex est Deus noster.*

Mi. Mark this Mystery Seven comprehendeth the Secrets of Heven and erth: Seven knitteth mans sowle and

body together. (3, in sowle, and 4 in body)

In 7, thow shalt finde the Unitie

In 7, thow shalt finde the Trinitie

In 7, thow shalt find the Sonne, and the proportion of the Holy Ghoste. O God, O God, O God, Thy Name (O God,)

7 < Thrones  
Trumpets  
Angells

be prayed ever, from thy 7 Thrones, from thy 7 Trumpets and from thy 7 Angels. Δ – *Amen, Amen, Amen.*

Mi. In 7, God wrowght all things.



Note: In 7, and by 7 must you work all things

O Seven tymes Seven, Veritie, Vertue and Majestie  
I Minister by thy licence This expownd, by thy  
Vertue (Δ – Michael spake that, pointing to Uriel.)

Δ Michael and Uriel both kneeled down, and the Pillers of fyrie  
and brasen cullour, cam nere, rownd abowt them uniformly.

Mi – *Sic est DEUS noster*

Δ One of the pillers leaned toward the skryer, and had like  
a pommel or mace hed, on the top of it. And Michael with  
great reverence toke out of the top of it a thing like an **S**

Δ Then leaned down **6** Pillers more: and Michael, cryed lowd  
*Unus est DEUS noster, Deus Deus noster*

Δ Then orderly he opened all the pillers heds: and then the 7 joynd  
all together, distinctly to be discerned

Mi. Note. Δ – There appeared, a great **S**  
**A**  
**A**  
**I**

Δ Then the sides closed up, and hid those letters first shewed.  
After that appered two letters more. **E**  
**M**

Δ He made cursy, and semed to go fromward, and vanished away.

*ΜΥΟΤΕΡΟΝ est E §*

Δ The Pillers all joynd together at the tops, making (as it were) one  
Mace or Pommell, and so flew up to heven wards.

NOTE Δ There seamed two pillers more to come down from heven  
(like the other in forme) and toke place there, where the  
other 7, stode, which went away.

Note the  
intrusion of  
Error by the  
Wicked powres  
of Sathan

Δ Michael with his sword, Cut them asunder: and cryed out,  
*Away you workers of Iniquitie*  
*Periit Malus cum malis.*

Δ The pillers fell down, and the grownd swallowed them up.  
*Tanta est tua audacia Sathan.*  
*Sed DEUS noster Vivit.*

Δ The Pillers which before ascended, cam down joyntly: and oute  
of them a Voyce saying ΔNON SUM

Δ Then the 7 pillers next his right hand, bowed to Michael, And  
oute of them, a Voyce sayd SUM

Δ Then one of the Pillers stode higher than his fellows, and Michael  
opened all the tops of them; and sayd  
*Orate.* Δ – We prayed.

Mi. Write the Name down in the Tables.

Δ Then he toke of, **3** of the heds of the Pillers, and sett them downe  
and there appered, **B T Z**, great letters in hollow places like  
square Cumfit boxes.

Mi. *Ista sunt secreta secretorum*

Δ  
Non Sum  
I understand  
the refusall of  
those two  
intruded  
pillers

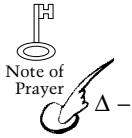

*Invocate Nomen eius, aut nihil agere possumus.*

The key of Prayer openeth all things.     Δ – We prayed.

Then the other 4 pillers, bowingly shewed 4 letters thus, **K A S E**, and the number **30** with a prik under

Then the Pillers joynd theyr heds together very close, and flew up into the firmament with Thunder.

*Sic Domine, Sic Sic.*

Mi – Place these in the Table     Δ – I wrote and he sayd, Thow hast done right.     *Laudate nomen Domini, qui vivit in æternum.*

Δ – A voyce cam out of the next cumpany of the 7 pillers (joyning them selves to gither) saying     *Ipse.*

Mi – *Et Misericordia tua Domine magna est.*

Δ – Michael kneled whan he sayd this

Δ – Michael shewed out of 4 of theyr heds, of the pillers, (and with all sayd) **NO, NOT** the Angels of heven, (but I,) are privie of these

things:     Δ – So there appeared, 4 letters, **H E I D**

Δ – Then the other 3 pillers were opened and had **E N E** on theyr tops

*Dominus collocatur in numero suo.*

Δ – The 7 pillers mownted up into the ayre, and it thundred at their going

Δ – Then the fourth Cumpany of pillers bowed to Michael: out of them cam a voyce.     *Vivo sicut LEO in medio illorum*

Mi. *Et tua potestas magna est Ubique*

Δ – Then Michael pluckt of, five of the tops.

There appered **D** then they joynd all to gither: then appere? **E I M O**

Mi. *Hoc est sine præce*

Δ – The other two opened, and there appeared **30 A**

Δ – Then they closed up, and went away, with a great thunder

Δ – Then cam 7 other pillers to Michael, and a voyce oute of them

Saying, *Serpens sum, et devoravi serpentem.*

Mi. *Et bonis et malis serpens es Domine*

Δ – Then they closed all up; and Michael sayd, *Orate.*     Δ – We prayed

Δ – Then Michaël toke of, the heds of 4: then appeared first an **I** then **M E G**

Then he opened the other 3. and **C B E** appeared.

Mi. *Numerus illius, est nulli cognitus.*

Δ – They joynd theyr heds all together, and ascended up to heven ward: and great lightening after them.

Δ – Then cam an other Septenarie of Pillers: and oute of them a Voyce, saying *Ignis sum penetrabilis*

Mi – *Et sit nobiscum, Ô Deus.*     Pray.     Δ – We prayed.

Δ – Then he opened 4 of theyr heds and appered in them **I L A O.**

Δ – They closed together agayne.

Δ – Then one other was opened, and **I** appered.

Δ – Then **21** appered, and did shut up agayn.

Δ – Then he smote fyre out of the last pyller, and it thundred and there seemed to come out of it innumerable Angels like little children

Note these     Innumerable Angels.

There is  
V omitted  
by our  
neglect

with wings, and there appere: **N**, and suddenly did shut up.

*Sic, sic, sic Deus noster.*

Δ – Then they joyned all together, and flew up.

Mi. Note down in the table. Δ – I noted them down.

Δ – Then cam the last 7 pillers, and out of them this voyce,  
*Finis.*

*Gaudium et Lux nostra Deus.*

Δ – Then they closed all in one.

Mi – *Orate* Δ – We prayed.

Δ – Then 6 of the heds opened and appered **I H R L A A**.

Δ – Then the seventh opened: Then seamed trees to leap up,  
and hills, and the seas and waters to be trubbled, and thrown up

Δ – A voyce cam out of the Pillers: *Consummatum est.*

Δ – There appeared in that Piller **21**  
**8**

Δ – They joyned together and flew up to heven ward.

Mi – **VNVS VNVS VNVS**

*Omnis caro timet vocem eius*

Pray. Δ – We prayed.

Δ – Note: my skryer was very faynt, and his hed in manner gyddy, and his eyes,  
dasyling, by reason of the sights seen so bright, and fyrie, &c.  
Michael bad of him be of good cumfort, and sayd he shold do well.

Mi – Cease for a quarter of an howre.

Δ – After we had stayed for a quarter of an howre, we comming to the  
stone agayne, fownd him come all ready to the stone: and Uriel  
with him. Who, allso, had byn by, all the while, during the  
Mysterie of the .7. pillers.

Mic – Set two stoles in the myddst of the flowre.

on the one, set the stone: and at the other let him knele.  
I will shut the eares of them in the howse, that none shall heare  
us. I will shew great Mysteries.

Michael than, with a lowd voyce sayd,

*Adeste Filiaē Bonitatis:  
Ecce DEVS vester adest:  
Venite.*

Δ – There cam in 7 yong women apparelled all in Grene, having theyr heds rownd abowt  
attyled all with greene silk, with a Wreath behinde hanging down to the grownd.  
Michael stroke his sword over them, no fyre appearing. Then they kneeled: And  
after, rose agayn.

Mi – *Scribe quæ vides.*

Δ – One of them stept out, with a little blue tablet in the forhed of her: and  
in it written, **EL**.

Δ – She stode a side, and an other cam in, after the same sort, with a great **M**, and a  
little e, thus, **Me**.

The Third, cam as the other, and had **Ese**

The fowrth \_\_\_\_\_ **Iana**

The fifth \_\_\_\_\_ **Akele**

The sixth \_\_\_\_\_ **Azdobn**

The seventh stepped furth with — **Stimcul**

*Filiae Bonita-  
tis, or Filiolæ  
lucis: vide  
pagina sequente.*



*Dixit Deus, Creavi Angelos meos, qui destruent Filias Terræ.*

Theyr attyre

*Adsumus, Δ – Sayd 7 little wenches which cam in.  
They were covered with white silk robes, and with  
white about theyr hed, and pendant down behinde,  
very long.*

Mi – *Vbi fuistis vos?* Δ – *They answered: In terris, cum sanctis  
et in cælis, cum glorificatis.*

Δ – These spake not so playn, as the former did; but as though they had an  
Impediment in theyr tung



Δ – They had, every one, somewhat in theyr hands, but my skryer could not judge  
what things they were. Mi. *Non adhuc cognoscetur Mysterion hoc.*

Δ – Eache had fowre square Tablets on theyr bosoms, as yf they were of white Ivory.

*Filiae  
Filiarum*

Δ – The first shewed on her Tablet a great **S**

The second \_\_\_\_\_ **Ab**

Ath

The third \_\_\_\_\_ **Ath**

The fowrth \_\_\_\_\_ **Ized**

The fifth \_\_\_\_\_ **Ekiei**

Madimi

The sixth \_\_\_\_\_ **Madimi**

The seventh \_\_\_\_\_ **Esemeli**

Mi – *Quid istis facietis?*

*Erimus cum illis, in omnibus operibus illorum.* Δ – They answered.

Mi – *Valete.* Δ – They answered, *Valeas et tu Magnus O in Cælis.*

Δ – And so they went away.



Mi – *Orate.* Δ – We prayed.

*Filii filiorum*

Mi – *Et misit filios filiorum, edocentes Israel.*

Mi – *Dixit Dominus, Venite ad vocem meam.*

Theyr Attyre

*Adsumus, Δ – Sayd 7 little childern which cam in,  
like boyes covered all with purple, with hanging sleeves  
like preists or scholers gown sleeves: theyr heds attyred all  
(after the former manner) with purple sylk.*

Mi – *Quid factum est inter filios hominum?*

*Male vivunt (sayd they) nec habemus locum cum illis*

*tanta est illorum Iniustitia. Veh mundo, scandalis:*

*Veh scandalizantibus, veh illis quibus Nos non sumus.*

Δ – These had tablets (on theyr brests) three cornerd, and seemed to be very grene  
and in them, letters. The first had two letters in one: thus, of E, L:

**E**

The first \_\_\_\_\_ **EL** — Δ He sayd, *Nec nomine meo timet Mundus.*

The second \_\_\_\_\_ **An** \_\_\_\_\_ *Nullus videbit faciem meam.*

The third \_\_\_\_\_ **Ave** — *Non est virgo super terram cui dicam.* [Δ And  
pointed to his tablet, wherein that  
word, Ave, was written.]

Rocle

The fowrth \_\_\_\_\_ **Liba** \_\_\_\_\_ *Tanta est infirmitas sanctitudinis Diei.  
Benefacientes decesserunt ab illo.*

The fifth \_\_\_\_\_ **Rocle** \_\_\_\_\_ *Opera manuum illorum sunt vana.  
Nemo autem videbit me.*

Hagonel. *Vide de  
hoc Hagonel, lib. 4.*

The sixth shewed his

Tablet and said, *Ecce – Hagonel – Qui adhuc Sancti sunt, cum illis vivo.*

The seventh had on his tablet — **Ilemese** — *Hii imitaverunt doctrinam meam.*  
*In me Omnis sita est Doctrina.*

Δ — I thought my skryer had missherd, this word *Imitaverunt*,  
 for *Imitati sunt*. And Michael smyled and seemed to lawgh,  
 and sayd, *Non curat numerum Lupus*. And farder  
 he sayd, *Ne minimam detrahet a virtute, virtutem*.

Mi — *Estote cum illis: Estote (inquam cum istis) Estote*  
*(inquam) mecum. Valete.*

Δ — So they went, making reverence, and went up to heven.

Mi — *Dictum est hoc tempore.*

Mi — Note this in thy Tables.

Dost thou understand it? Loke if thou canst.

Urielis officium

Δ — He sayd to Uriel, it is thy part, to interpretate these things.

Ur. *Omnis Intelligentia est a Domino.*

Mi — *Et eius Nomen est Halleluyah.*

Compose a table, divided into 7 parts, square.

Note this Table is made perfect in the next side following.

|                 |                           |                           |                              |                              |   |                            |
|-----------------|---------------------------|---------------------------|------------------------------|------------------------------|---|----------------------------|
| S               | A                         | A                         | I <sup>21</sup> <sub>8</sub> | <del>M</del> <sup>E</sup>    | <del>E</del> <sup>M</sup>               | E <sub>8</sub>             |
| B               | T                         | Z                         | K                            | A                            | S                                       | E <sub>30</sub>            |
| H               | E                         | I                         | D                            | E                            | N                                       | E                          |
| D               | E                         | I                         | M                            | O                            | <sub>30</sub>                           | A                          |
| I <sup>26</sup> | M                         | E                         | G                            | C                            | B                                       | E                          |
| I               | <del>A</del> <sup>L</sup> | <del>L</del> <sup>A</sup> | O                            | I <sup>21</sup> <sub>8</sub> | <del>V</del> <sup>21</sup> <sub>8</sub> | N                          |
| I               | H                         | R                         | L                            | A                            | A                                       | <sup>21</sup> <sub>8</sub> |

7. Names of God

Ur. Those 7 names, which procede from the left hand to the right, are the Names of God, not known to the Angels: neyther can be spoken or red of man. Prove if thou canst reade them.

*Beatus est qui secreta*

*Nomina sua conservat.*

Note these two orders of Angels: and Note Uriel doth have him self one of the standers before the face of God

Ur. These Names, bring furth 7 Angels: The 7 Angels, and Go= vernors in the hevens next unto us\*, which stand allwayes before the face of God.

*Sanctus Sanctus Sanctus*

*est ille DEVS noster.*

Ur. Every letter of the Angels names, bringeth furth 7 dowghters.

Every dowghter bringeth furth her dowghter, which is

7. Every dowghter her dowghter bringeth furth, a sonne. Every sonne in him self, is 7. Every sonne

NOTE well this Rule of Arte.

hath his sonne, and his sonne is 7.

Let us praye the God of Seven, which was and is  
and shall live for ever.

*Vox Domini in Fortitudine*

*Vox Domini in Decore*

*Vox Domini revelat Secreta.*

*In templo eius, Laudemus Nomen eius El*

*Halleluyah*

*Filiae*

See if thou canst now understand this table.

The Dowghters procede from the angle on the right hand, cleaving  
the myddle: where theyr generation ceaseth.

*Filii*

The sonnes from the left hand to the right to the middle:  
so proceding where they number endeth in one Centre.

Note this  
manner of  
center  
accown=  
ted.

Δ —

The Residue thou mayst (by this Note) understande.

Then Michael, he stroke over us ward, with his sword, and the flame  
of fire yssued oute.

Note of Numbers  
with priks  
signifying letters.

Loke to the Corner of the right hand, being the uppermost: where thou  
shalt finde §. Refer thyne eye to the upper number, and the  
letter above it. But the Number must be fownd under neth,  
bycause his prick so noteth.

Than procede to the names of the dowghters in the Table: and thou  
shalt see that it is the first name of them: This shall teache  
the.

l the first  
daughter

Δ —

Loking now into my first and greatest Circle for §, I finde it with  
I over it. I take this to be the first Dowghter.

Ur.

You must in this square Table set E by the § and now  
write them composedly in one letter, thus **E**

**E**

*Nomen Domini vivit in æternum.*

Ur.

Give over, for half an howre, and thou shalt be fully  
instructed.

Δ —

I did so, and after half an howre comming to the stone,  
I was willed to make a new square table of 7: and  
to write and note, as it followeth.

|                 |   |   |                                |                                |    |                              |                              |
|-----------------|---|---|--------------------------------|--------------------------------|----|------------------------------|------------------------------|
| S               | A | A | I <sup>21</sup> / <sub>§</sub> | E                              | M  | E <sup>§</sup>               | – <i>Vivit in cælis</i>      |
| B               | T | Z | K                              | A                              | S  | E <sup>30</sup>              | – <i>Deus noster</i>         |
| H               | E | I | D                              | E                              | N  | E                            | – <i>Dux noster</i>          |
| D               | E | I | M                              | O                              | 30 | A                            | – <i>Hic est</i>             |
| I <sup>26</sup> | M | E | G                              | C                              | B  | E                            | – <i>Lux in æternum</i>      |
| I               | L | A | O                              | I <sup>21</sup> / <sub>§</sub> | V  | N                            | – <i>Finis est</i>           |
| I               | H | R | L                              | A                              | A  | <sup>21</sup> / <sub>§</sub> | – <i>Vera est hæc tabula</i> |

*Vera est hæc Tabula, partim nobis cognita, et partim omnibus,  
incognita. Vide iam.*

The **30** by E, in the second place, in the upper right corner, serveth not  
in the consideration of the first Dowghters, but for an other purpose.

Note these  
other pur=  
poses

The **26** by **I**, serveth for an other purpose: but not for this Dowghters Dowghter.

The **21**, is **e**, and **8** with the prick under it is **l**: which together maketh **El**, or thus compownded as if it were one letter, **E**

The Names in the great Seale must follow the Orthographie of this Table. *Virtus Vobiscum est.*

*Orate.* Δ – We prayed.

Δ – Then there appeared **S A A I 21 M E**. Here is an **E** comprehended in **L**.  
Ur. Read now the Table.

*Angeli  
Lucis*

*Angeli lucis Dei nostri*

*Et posuit angelos illius in medio illorum*

Ur. In the table are the names of 7 Angels. The first is Zabathiel, beginning from the left uppermost corner: taking the corner letter first, and then that on the right hand above: and than that under the first, and than the third from the first, in the upper row: and then cornerwise down toward the left hand: and then to the fowrth letter from the first in the upper row: where there is **I** with **21**, which maketh **el**. So have you **Zabathiel**.

1. Ur. Go forward. Δ – So, I finde next **Zedekieil**.

The true sownd Ur. this **I** in the last syllable augmenteth the true sownd of it.

3. Δ – Then next I finde **Madimiel**.— Ur. it is so.

4. Δ – Then ————— **Semiel**. — Ur. it is true.

5. Δ – Then ————— **Nogahel**. — Ur. it is so.

6. Δ – Then ————— **Corabel**. — Ur. it is so.

7. Δ – Then ————— **Levanael**. — Ur. it is so.

Δ This name Corabel you may see in *Elementis Magicis Petri de Abano* in the *Considerations Diei* )

Ur. Write these names in the Great Seal, next under the 7 names which thow wrotest last: *videlicet*, under **E**, **An**, **Ave**, *&c.* distinctly in great letters.

Ur. Make the **E** and **L** of **Zabathiel**, in one letter compownded, thus **ZABATHIE**. In this, so fashion your **E** and **L**. And this name must be distributed in his letters into 7 sides of that innermost Heptagonum. For the other, I will teache you to dispose them. You must make for **IEL** (in this name onely) **I** with the **21** annexed. So have you just 7 places.

Ur. The next five names thow shalt dispose in the five exterior angles of the Pentacle: every angle conteyning one whole name.

Ur. Set the first letters of these 5 names, (in Capitall letters) within the five acute internall angles of the Pentacle: and the rest of eche name following circularly from his Capitall letter, but in the 5 exterior obtuse angles of the Pentacle.

Ur. Set **Z**, of **Zedekieil** within the angle which standeth up toward the begynning of the greatest Circle. And so procede toward thy right hand.

Ur. In the middle now of thy Pentacle, make a cross  like a crucifix and write the last of those 7 names **Levanael** thus,



Uriel. *Vidit DEVS, opus suum esse bonum  
et cessavit a Labore suo.  
Factum est.*

Δ – Michael stode up and sayd,  
The æternall Blessing of God the FATHER,  
The mercifull Goodnes of CHRIST, his SONNE  
The unspeakable Dignitie of GOD the Holy GHOSTE  
bless you, preserve you, and multiply your  
doings in his Honor and Glory.

Uriel. *AMEN.*

Ur. | These Angels are the angells of the 7 Circles of Heven,  
| governing the Lightes of the .7. Circles.

Note these  
two order  
of Angels

Blessed be GOD in us, and by us,  
Which stand contynually before  
the presence of GOD, for ever.

*DIXI.*

Δ – Whan may we be so bold, as to require your help agayn?

Mic – Whan so ever you will, we are ready.

Farewell.

Δ – *Sit Nomen Domini benedictum, ex hoc nunc,  
et usque in sæcula sæculorum.  
Amen.*



*Anno Domini* } At  
*1582* } Mortlake by  
*Martii 21.* } Richemond







*Mysteriorum, liber*  
*Tertius* Δ

*Anno 1582:*

*Aprilis 28:*

*Liber 3<sup>o</sup>*  
*Liber 4<sup>o</sup>*



Anno 1582 Aprilis 28 a meridie hora 4.

E.T: Onely Michael appeared; Δ: And to diverse my complaynts, and requests sayde,

Mi: The lord shall consider thee in this world, and in the world to come.

E.T: All the chayre seemed on fyre.

Mi: This is one Action, in one person: I speak of you two.

Union  
of us

Δ: You meane us two to be joynd so, and in mynde united, as yf we wer one man?

Mi: Thou understandest.

Take heade of punishment for your last slaknes.

Δ: Yf you mean any slaknes on my behalf, Truely it was and is for lak of habilitie to buy and prepare things, appointed of you. Procure I pray you habilitie, and so shall I make spede.

E.T: A great hill of gold with serpents lying on it appeared: he smyteth it with his sword, and it falleth into a mighty great water, hedlong.

Mi: Dost thou understand? Δ: No verylie.

worldly  
habilitie

E.T: He razed the hill away, as though there had byn none; and sayd,

Mi: Lo, so it is of this worldly habilitie.

Δ: I pray you how must the Lamine be hanged?

The  
Lamin  
not simpler  
spoken: for  
no such lamyn  
was to be  
made

Mi: As concerning the Lamine, it must be hanged unseen, in some skarf.

The Ring when it is made, I will lessen it according to my pleasure.

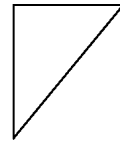

I meane by two Cubites, your usuall yarde.

Haste, for thou hast many things to do.

Glory be to God, Peace unto his Creatures. Mercy to the wicked,

Forgivenes to the Faithfull: He liveth, Ô he rayngneth, O

Pele  
Ese

thow art mighty, PELE: thy name be blessed. Δ: Amen.

*Venito Ese*, Δ: He cryed so with a lowd voyce.

E.T: he is now covered, in a myghty covering of fyre, of a great beawty.

There standeth a thing before him. I cannot tell what it is.

*Laudate Dominum in cælis.*

*Orate.* Δ: we prayed.

E.T: His face remayneth covered with the fyre, but his body uncovered.

Mi: *Adesdum Ese.*

Iana

*Adesdum Iana.*

*Vobis dedit demonstracionem in Tabulis vris.*

E.T: There appeare of the figure, (before, imperfect) two little women:

One of them held up a Table which lightened terribly: so that all the stone was covered with a myst.

A voyce cam out of the myst, and sayd,

Creatio

*Ex hiis creata sunt, et hæc sunt nomina illorum.*

E.T: The myst cleareth, and one of the women held up a Table, being thus written uppon.

*Numerus Primus.*

Δ: The Table semed square, and full of letters and numbers, and Crosses, in diverse places, diversly fashioned.

Δ: Remember, Ese and Iana; ar the thirdth and fowrth of the *Septem Filiaë Bonitatis, supra lib<sup>o</sup>. 2. °* They are thus in order these: EL, Me, Ese, Iana, Akele, Azdobn, Stimcul.

A finger cam out of the mist, and wyped oute, the first shew, with the Cross, letters, and numbers.

The second was in like wise.

The Third was a b with the tayle upward thus: *g*

The 52 with the three great **BBB** seme to be covered with Gold.

The two Crossed ones he did not wipe out with his finger.

The next he blotted oute.

He blotted not oute the three *b* with the 8 and 3.

The two *b* barrs must go clere *b* and not towch the *b b b* the bars.

The *g*, the square, wherin it standeth, is all gold: *b b b*  
and that he let stand.

Fire cam oute and burnt 

|             |          |
|-------------|----------|
| <i>b</i>    | <i>b</i> |
| <i>1556</i> | <i>6</i> |

The 

|            |          |          |
|------------|----------|----------|
| <i>b</i>   | <i>b</i> | <i>b</i> |
| <i>123</i> | <i>4</i> | <i>5</i> |

 is all of a bright cullour, like the brightnes of the Sonne, and that was not put out.

The places are very black, but where the letters, and numbers do stand.

E.T. hard a voyce saying, *Finis Tenebrarum: Halleluyah.*

E.T: There commeth a hand and putteth the little woman into the clowde.

Mi: Prayse God: Be inwardly mery.

The Darkness is comprehended.

God bless you: God bless you: God blesse you.

You must leave of for an howre and a half: for you have .6. other

Tables to write to night.

Prayse God: be joyfull.



After supper we resorted to our scholemaster.

E.T: I here a voyce but see nothing: he sayeth,

*Initium bonum in nomine ejus*

*et est. Halleluyah.*

E.T: Three quarters of the stone (on the right side) are dark, the other quarter is clere.

*Filiae filiarum*  
Ese  
*vide lib. 2<sup>o</sup>*  
Δ somewhat wanteth

Mi: *Venite filiae filiarum ESE.*

The nethermost . . . .

E.T: There come six yong maydens, all in white apparell, alike:

Now they all be gonne into the dark parte of the stone, except one.

There cam a flame of fyre out of the dark, and in the flame written

Vnus on this manner: *V nus nus nus*

Lux

She that standeth without, putteth her hand into the dark: and pulleth out a ball of light: and threw it oute: and it waxed bigger and, bigger and it Thundred.

E.T: A voyce sayd, *Dies primus.*

An other voyce : *Ubi est Tabula?*

an answer : *Est, Est, Est.*

She wyndeth and turneth her self abowt, begynning at her hed, and so was Transformed into a Table, rownde.

E.T: Three faces do shew and shote oute, and ever returned into one hed

agayne: and with it cam a mervaylous swete savour.

The Table cullored

The Table was of three cullours: white, redd, and a mixture of white

Numerus Primus

|  |  |  |  |  |  |  |  |
|--|--|--|--|--|--|--|--|
| $\begin{matrix} 2 \\ \text{I} \\ \text{b} \end{matrix}$                              | $\begin{matrix} \text{G} \\ \text{b} \end{matrix}$                                   | $\begin{matrix} \text{g} \\ \text{b} \end{matrix}$                                   | $\begin{matrix} \text{B} \\ 22 \end{matrix}$   | $\begin{matrix} 2.4.6 \\ \text{b} \end{matrix}$                | $\begin{matrix} \text{L} \\ \text{b} \end{matrix}$             | $\begin{matrix} \text{B} \\ \text{rog} \end{matrix}$             | $\text{Ⓟ}$   |
| $\begin{matrix} 8 \\ \text{b} \\ \text{b} \end{matrix}$                              | $\begin{matrix} \text{ff} \\ 8 \end{matrix}$   | $\begin{matrix} \text{G} \\ \text{b} \end{matrix}$                                   | $\begin{matrix} \text{G} \\ \text{b} \end{matrix}$                                   | $\begin{matrix} 152 \\ \text{b} \end{matrix}$                  | $\begin{matrix} 152 \\ \text{b} \end{matrix}$                  | $\begin{matrix} 52 \\ \text{BBB} \end{matrix}$                   | $\begin{matrix} \text{B} \\ \text{---} \\ \text{B} \end{matrix}$ |
| $\begin{matrix} \text{D} \\ \text{q} \\ \text{q} \end{matrix}$                       | $\begin{matrix} \text{b} \\ \text{o} \\ \text{o} \end{matrix}$                       | $\begin{matrix} \text{B} \\ 7 \end{matrix}$  | $\begin{matrix} \text{b} \\ \text{b} \\ \text{b} \\ \text{b} \end{matrix}$           | $\begin{matrix} 11 \\ \text{B} \\ 5 \end{matrix}$              | $\begin{matrix} \text{b} \\ \text{b} \\ \text{b} \end{matrix}$ | $\begin{matrix} \text{b} \\ \text{b} \\ \text{b} \end{matrix}$   | $\begin{matrix} \text{b} \\ \text{b} \\ \text{b} \end{matrix}$   |
| $\begin{matrix} \text{b} \\ \text{b} \\ \text{b} \end{matrix}$                       | $\begin{matrix} \text{b} \\ \text{b} \\ \text{b} \end{matrix}$                       | $\begin{matrix} \text{b} \\ \text{b} \\ \text{b} \end{matrix}$                       | $\begin{matrix} \text{M} \\ 7 \end{matrix}$  | $\begin{matrix} \text{b} \\ \text{b} \end{matrix}$             | $\begin{matrix} \text{G} \\ \text{M} \\ \text{I} \end{matrix}$ | $\begin{matrix} \text{M} \\ \text{---} \\ \text{A} \end{matrix}$ | $\begin{matrix} \text{b} \\ \text{A} \\ 1556 \end{matrix}$       |
| <del><math>\begin{matrix} \text{b} \\ \text{b} \\ \text{b} \end{matrix}</math></del> | <del><math>\begin{matrix} \text{b} \\ \text{b} \\ \text{b} \end{matrix}</math></del> | <del><math>\begin{matrix} \text{b} \\ \text{b} \\ \text{b} \end{matrix}</math></del> | <del><math>\begin{matrix} \text{b} \\ \text{b} \\ \text{b} \end{matrix}</math></del> | $\begin{matrix} \text{b} \\ \text{b} \\ \text{b} \end{matrix}$ | $\begin{matrix} \text{b} \\ \text{b} \\ \text{b} \end{matrix}$ | $\begin{matrix} \text{b} \\ \text{b} \\ \text{b} \end{matrix}$   | $\begin{matrix} \text{b} \\ \text{b} \\ \text{b} \end{matrix}$   |

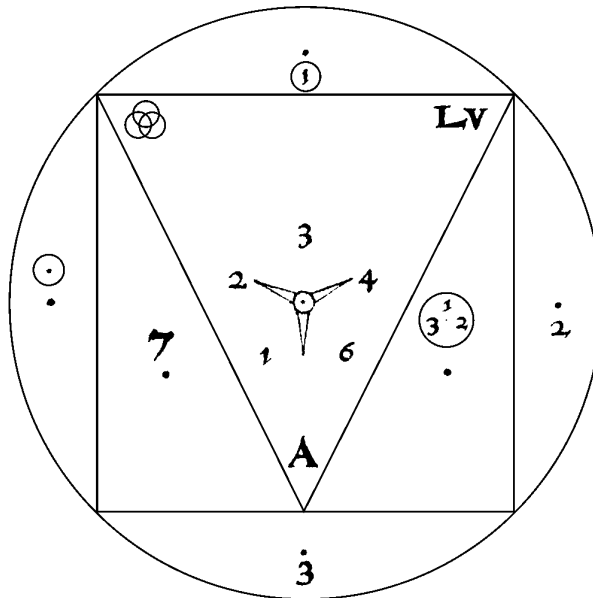

- Δ Of these seven tables, characters, or scotcheons consider the words spoken in the fifth boke A° 1583, April 2d How they are proper to every King and prince in their order.

They are Instruments of Conciliation

*/Volumine 5°./*

where my Character is fashioned

|                   |                        |                        |
|-------------------|------------------------|------------------------|
| G<br>23<br>B†     | m·30 q<br>B·9·<br>d·4· | q·q·q Q<br>B<br>o·g og |
| f B 30<br>G 33· A | †—†<br>B<br>A—O        | £ B get<br>h go        |
| 5 b C<br>↗        | d2 id<br>d b 2A        | L b 30<br>pp           |
| V b H<br>9 22     | q·q·q Q<br>b a         | L b 25<br>d            |

|              |              |             |                         |             |                             |
|--------------|--------------|-------------|-------------------------|-------------|-----------------------------|
| 2<br>bb<br>2 | b b<br>▽     | 537<br>bbb  | b B<br>G n              | T·13<br>bbb | b 9                         |
| v·2<br>B     | o 4<br>BB    | B 14<br>n   | bb·b<br>P·3·            | b<br>GO     | bb<br>C·V<br>3              |
| 8 e<br>b     | Q·o<br>b 7 b | ∞<br>5      | q q<br>b 3              | q·9<br>B    | L <sup>b</sup> <sub>8</sub> |
| go 30<br>B   | 9·3<br>b b   | q q<br>·b·b | d T<br>b T <sub>A</sub> | 7·2<br>b·B  | BB<br>·Λ·<br>8 3            |

and red, changeably. A strong sownding cam withall, as of clattring of harness or fall of waters; or such like.

There cam a sterre shoting oute of the dark, and settled itself in the myddle of the Table: And the fyre which cam oute with the woman, did cumpas the Table abowt.

A voyce sayd, *O honor, Laus et gloria, Tibi qui es, et eris*

The Table sheweth wunderfull fayre and glorious.

Onely seven priks appeare on the Table.

The three angles of the triangle open, and in the lower point appeared a great **A**.

And in the right upper corner **LV**. (E.T: The Table trembled.)

And in the other Corner appeared thre circles of equall bignes, equally, or alike intersecting eche other  by theyr centers.

A voyce: *Unus est, Trinus est; in omni Angulo est.*

*Omnia comprehendit: Fuit, est, et vobis erit.*

*Finis et Origo.* (E.T: ô, ô; with a dullfull sownd, he pronownced.)

E.T: The woman sayeth, *Fui: sum quod non sum.* <sup>Δ forte fui</sup>

A voyce: *Lux non erat et nunc est.*

E.T: The woman being turned, from the shape of the Table, into womans shape agayn, went into the dark.

Then one part of the darknes diminished. In the dark was a mervaylous turmoyling, tossing, and stur, a long tyme during.

A voyce: For a tyme Nature can not abyde these sightes.

E.T: It is become Quiet, but dark still.

Prayer

A voyce: Pray and that vehemently, For these things are not revealed without great prayer. 

E.T: After a long tyme there cam a woman: and flung up a ball like a glass: and a voyce was hard saying, *Fiat*.

The ball went into the darknes, and browght with it a great White Globe hollow transparent.

Then she had a Table abowt her neck, square of 12 places.

The woman seamed to daunce and swyng the Table:

Then cam a hand oute of the dark: and stroke her and she stode still, and becam fayrer: She sayd, *Ecce signum Incomprehensibilitatis;*

Water

E.T: The woman is transformed into a water, and flyeth up into the Globe of Light. 

E.T: A voyce: *Est, Est, Est.*

E.T: One commeth, (a woman) owt of the Dark, very demurely, and soberly walking, carrying in her hand a little rownd ball: and threw

it into the dark: and it becam a great thing of Earth. She taketh it in her hand agayne, and casteth it up into the rownd Globe and sayd,

Erth

*Fiat.*

E.T: She turned her back toward E.T. and there appeared a Table divided in 24 parts. yt seemeth to be very square.

A voyce: *Scribe. Veritas est.*

Man  
Woman

E.T: A sword cam out of the Dark: and clave the woman a sunder, and the one half becam a man, and the other a woman, and they went and sat uppon the Ball of cley or erth. 

Now seemeth the Dark part to quake.

A voyce ——— *Venito vasedg.*

E.T: There cometh a woman oute of the Dark: she sayd,  
*Vita hiis ex mea manu.*

E.T: She sheweth a Table square full of holes, and many things creeping out of it. This Square is within a rownd.

A voyce ——— *O Lux Deus noster.*  
*Hamuthz Gethog*

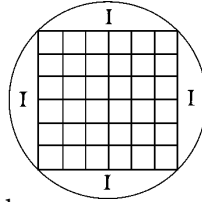

E.T: Then stept out an other woman having a sword in her hand. She toke a thing oute of the dark (a bright thing) and Cut it in twayn and the one parte she cut into two unequal partes, and the other half she cutteth into a thowsand (or innumerable) partes. Then she toke all the partes up into her skyrt. She hath a Table, and it hangeth on her sholders She stept before the other woman, whose hed standeth in the dark.

Note this stepping before.

This woman her Table is fowre square. She is very bewtifull.

She sayd, *Lumina sunt hæc Intelligentiae tuæ.*

She sayd, *Fere nulli Credendus est hic numerus.*

The sterrs, sonne and Mone created

This woman taketh the little peces, and casteth them up, and they become little sparks of light: and of the things she cast, There were two great rownd things. And they were also cast up to the white Transpa= rent Globe. And she went away into the Dark: which was, now, very much lessened.



Then the other woman (who was forestept) thrust oute her hed who had the rownd conteyning the Square, with the 36 places. She crymbleth clay, and it turneth to byrds. She seameth to be like a witch. Into the bosse of her Table, she put her hand and that bosse, was in the Dark and oute of the bosse, she seemed to fatch that Clay. She sayd,

*Ad usum tuum Multiplicati sunt.*

E.T: She went into the Dark.



|  |   |   |   |  |                        |          |  |
|--|---|---|---|--|------------------------|----------|--|
| $\mathcal{J}$<br>D <sub>2</sub><br>$\mathcal{J}$ | $\begin{array}{ c } \hline B \\ \hline \end{array}$<br>30       | $\begin{array}{ c } \hline B \\ \hline \end{array}$<br>8<br>2           | $\begin{array}{ c } \hline B \\ \hline \end{array}$<br>22         | $\begin{array}{ c } \hline B \cdot O \\ \hline \end{array}$<br>p<br>30 | L 0<br>B · 9<br>q · 29 | B<br>82  | $\frac{9}{6}$<br>B   |
| o p<br>B<br>98                                   | $\begin{array}{ c } \hline \text{H} \\ \hline \end{array}$<br>B | $\begin{array}{ c } \hline \text{H} \\ \hline \end{array}$<br>2.<br>8 G | $\begin{array}{ c } \hline \text{H} \\ \hline \end{array}$<br>9 F | b<br>3 Q   | bbb<br>9 Q             | b<br>ü Q | BB<br>iz<br>T  |
| BB<br>b 8  | M<br>2<br>b b   | M<br>b 3  | M<br>b b<br>b 20  | M<br>b · 89<br>F   | d B<br>17              | A<br>b 3 | $\begin{array}{ c } \hline B \\ \hline \end{array}$<br>B<br>2<br>H |
| M<br>b 99<br>L                                   | b 6<br>T<br>4 b   | b<br>T<br>b   | bb<br>T<br>9 I 6  | 6 B<br>2 4   | T<br>B 38              | N<br>B 9 | b 6 4<br>b   |

Note this cross with the two bees, the 4 and the 6, is one of the Notes annexed to the second Table of the 4 of Enoch's Tables: And the T of Enoch's Tables semeth to answer with the T first in the scale of Aemeth, and the cross also.

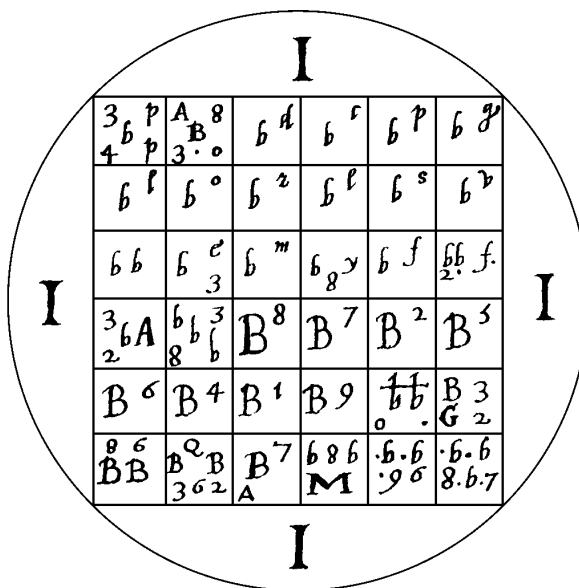

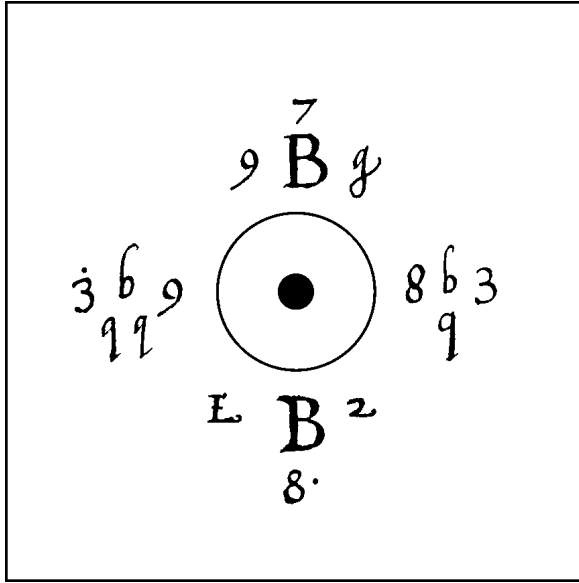

E.T: A Voyce is hard saying,  
*Omnia gaudent fine.*

...] hearbs,  
 &c.  
 E.T: There commeth oute a woman; out of the Dark. She plucketh at  
 the dark, and casteth it on the grownd, and it turneth to herbes, and plants  
 becomming like a garden, and they grow up very fast. She sayd,  
*Opus est.*

...] Centre }  
 ...] Darknes }  
 E.T: She hath a fowre square Table before her.  
 Then cam one, all in white, and taketh the Darknes, and wrappeth it up  
 and casteth it into the myddle of the Erthen Globe, on which appeared  
 Trees and plants.

E.T: Then appered Michael, his Chayre, and Table agayne manifestly: which  
 all this while, were not seen.

Mi: *Obumbrabit vestigia vestra veritatis Luce.*  
 The Actor, The Actor, The Actor:  
 One Disposer; he, which is one in all; and All in all:  
 bless you from the wickednes of Deceyte: Create you  
 new vessels: To whome I commyt you.

E.T: he holdeth his sword over us, in manner, out of the stone.  
 Mi: Fare Well. Serve God. Be patient.  
 Hate vayne glorie. Live justly. Amen.

Δ: What spede shall I make for the yard square Table, the wax, the  
 seale, and the Character? Mi: As thow ar motioned, so do.

Δ: *Gloria, Patri et F. et S.S. S.e.i.p.e.n.e.s.e.r.s.s. amen.*

Δ: Note, All the Tables before were by E.T, letter for letter noted out  
 of the stone standing before him all the while: and the  
 7 Tables following wer written by me as he repeted them orderly out of the stone.

Aprilis 29: Sunday: Nocte hora 8 1/4

E.T : Two appeare, Michael and Uriel.

Mi: *Et posuit illos in ministerium ejus.*  
*Quid desideratis?*

Δ: *Sapientiam et scientiam nobis necessariam, et in Dei servitio potentem  
 ad eius gloriam.*

Mi: *Sapere, a Deo: Scire a Creatura et ex creaturis est.*

Δ I am not sure  
 if it wer Mi.  
 or Ur, that  
 called for them.  
 Δ  
 Ur: *Venite filiae.*

E.T: Seven women appeare bewtifull and fayre.  
 Mi: This work is of wisdom (Δ: Sayd Michael, and stode up.)  
 E.T, sayd to me (Δ), He putteth oute his sword and willeth me to sweare, to  
 that, that he willeth me: and to follow his cownsayle.

Mi: Wilt thou. Δ: Then with much ado, E.T. sayd as followeth,  
 E.T: I promise, In the name of God the Father, God the sonne and God  
 the holy ghost, to performe that you shall will me, so far as it  
 shall lye in my powre.

E.T: Now they two seeme to confer together.  
 Mi: Now you towche world, and the doings upon earth.  
Now we shew unto you the lower world: The Governours that  
 work and rule under God: By whome you may have

E.T. his  
 promise

practise.  
 The lower  
 world

powre to work such things, as shalbe to god his glorie, profit of your Cuntries, and the knowledge of his Creatures.

To E.T. he spake,

What I do wish thee to do, thou shalt here know, before thou go. We procede to one GOD, one knowledge, one Operation.

Filiae

*Venite filiae.*

49 good Angels Governors

Behold these Tables: Herein lye theyr names that work under God uppon earth: not of the wicked, but of the Angels of Light. The whole Government, doth consist in the hands of 49 (in God his Powre, Strength, Mercy, and Justice) whose names are here evident, excellent, and glorious.

The first knowledge

Mark these Tables: Mark them. Record them to your [...]

This is the first knowledge. Here shall you have Wisdome. *Halleluyah.*

Mighty and Omnipotent art thou, O God, God, God, amongst thy Creatures: Thou fillest all things with thy excellent foresight. Thy Glorie be amongst us for ever. Δ: Amen.

E.T: All the 7 (which here appeare) joyne theyr Tables in One, which, before they held apart. And they be of this Forme all to\_gither. The myddel most is a great Square and on eche side of it, One, as big as it, joyning close to it. And over it joyned two, which both together wer æquall to it: and under it, wer such other two, as may appear in this little pattern. Being thus joyned, a bright circle did cumpas and enclose them all, thus: but nothing was in the Circle.

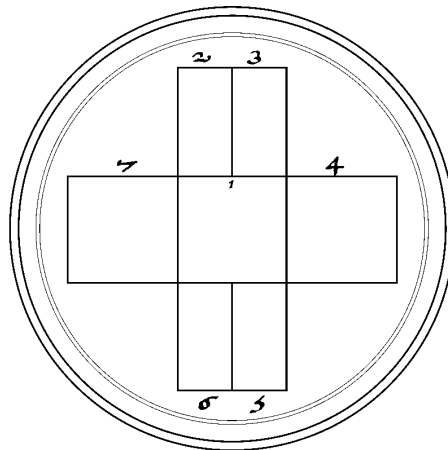



2

|      |      |      |      |      |      |      |  |  |  |
|------|------|------|------|------|------|------|--|--|--|
| 7 A  | 21 O | 1 A  | 26 E | 48 A | 24 A | 13 R |  |  |  |
| 34 I | 8 O  | 29 M | 2 O  | 33 A | 6 M  | 25 E |  |  |  |
| 49 A | 4 E  | 35 A | 10 M | 18 L | 28 M | 23 L |  |  |  |
| 39 V | 47 L | 3 A  | 5 L  | 15 A | 36 N | 30 R |  |  |  |
| 20 E | 19 R | 45 A | 37 R | 32 I | 17 A | 41 A |  |  |  |
| 10 A | 38 O | 16 V | 27 A | 12 R | 43 R | 22 Y |  |  |  |
| 9 E  | 44 A | 11 E | 42 L | 31 A | 14 N | 46 V |  |  |  |

7

|      |      |      |      |      |      |      |      |      |      |      |
|------|------|------|------|------|------|------|------|------|------|------|
| 14 E | 49 E | 7 F  | 25 A | 13 I | 47 F | 16 O | 1 B  | 2 B  | 3 B  | 4 B  |
| 46 A | 36 N | 44 L | 42 N | 18 M | 45 O | 6 L  | 8 B  | 9 B  | 10 B | 11 B |
| 12 O | 41 O | 26 I | 43 A | 29 L | 39 B | 33 S | 15 B | 16 B | 17 B | 18 B |
| 48 T | 31 O | 2 O  | 32 B | 9 S  | 38 A | 8 L  | 22 B | 23 B | 24 B | 25 B |
| 28 S | 15 L | 17 A | 10 O | 3 O  | 30 S | 20 E | 29 B | 30 B | 31 B | 32 B |
| 40 L | 34 N | 37 S | 19 P | 4 E  | 5 O  | 22 R | 36 B | 37 B | 38 B | 39 B |
| 24 R | 1 N  | 35 O | 23 N | 11 E | 21 N | 17 A | 43 B | 44 B | 45 B | 46 B |

|      |      |      |      |      |      |      |  |  |  |
|------|------|------|------|------|------|------|--|--|--|
| 36 E | 47 E | 14 L | 27 F | 49 D | 13 L | 16 N |  |  |  |
| 12 L | 32 A | 26 G | 24 O | 41 R | 31 L | 19 O |  |  |  |
| 22 O | 29 O | 2 G  | 7 D  | 25 R | 1 O  | 5 P  |  |  |  |
| 6 A  | 15 E | 34 O | 4 M  | 33 E | 30 E | 20 L |  |  |  |
| 37 E | 9 E  | 18 O | 10 L | 21 O | 28 E | 3 D  |  |  |  |
| 17 M | 39 A | 35 G | 38 L | 8 E  | 11 L | 23 O |  |  |  |
| 44 O | 43 Z | 48 R | 10 O | 45 B | 42 A | 46 A |  |  |  |

6

3

|      |      |      |      |      |      |      |
|------|------|------|------|------|------|------|
| 6 A  | 7 S  | 29 A | 15 B | 23 I | 8 B  | 17 Z |
| 36 A | 39 S | 12 A | 30 O | 1 L  | 10 S | 21 N |
| 5 V  | 31 S | 25 L | 45 B | 26 N | 32 N | 3 P  |
| 18 I | 19 A | 48 R | 4 S  | 27 R | 34 N | 24 L |
| 38 R | 44 G | 37 A | 20 R | 16 T | 2 R  | 22 N |
| 49 M | 43 V | 35 R | 47 I | 9 F  | 33 R | 42 I |
| 13 I | 46 S | 11 R | 41 R | 40 I | 28 I | 14 A |

4

|      |      |      |      |      |      |      |      |      |      |      |
|------|------|------|------|------|------|------|------|------|------|------|
| 4 B  | 5 B  | 6 B  | 7 B  | 6 M  | 41 T | 39 C | 19 G | 49 N | 45 L | 14 G |
| 11 B | 12 B | 13 B | 14 B | 31 P | 25 M | 2 N  | 18 N | 44 E | 8 O  | 30 R |
| 18 B | 19 B | 20 B | 21 B | 7 L  | 15 A | 38 M | 32 O | 43 M | 29 S | 28 L |
| 25 B | 26 B | 27 B | 28 B | 35 D | 37 L | 3 N  | 13 S | 42 I | 12 N | 33 I |
| 32 B | 33 B | 34 B | 35 B | 1 I  | 17 P | 16 M | 46 D | 5 M  | 40 N | 21 E |
| 39 B | 40 B | 41 B | 42 B | 27 N | 23 S | 4 G  | 36 P | 26 P | 47 N | 20 M |
| 46 B | 47 B | 48 B | 49 B | 9 A  | 10 M | 24 C | 22 E | 34 O | 11 N | 48 F |

|      |      |      |      |      |      |      |
|------|------|------|------|------|------|------|
| 8 G  | 41 I | 16 O | 48 O | 43 A | 7 A  | 45 O |
| 3 D  | 19 I | 44 N | 13 F | 47 G | 38 I | 3 I  |
| 7 E  | 15 A | 2 O  | 27 A | 42 G | 10 E | 18 T |
| 31 A | 12 G | 25 A | 20 A | 40 P | 15 L | 29 P |
| 6 G  | 23 D | 22 P | 1 G  | 30 G | 5 A  | 46 V |
| 37 G | 9 F  | 4 E  | 24 E | 34 F | 33 G | 21 F |
| 36 S | 45 I | 26 A | 14 O | 39 N | 11 O | 18 G |

5

The Circle abowt was bright  
and Nothing in it./



ET: One stept furth, and sayde,  
 1: { Wilt thou have witt, and wisdome:  
 Here, it is. (Δ: Pointing to the middle table.)  
 2: { An other sayd, The Exaltation and Government of Princes, is in my  
 hand. (Δ: Pointing to that on the left hand of the two uppermost.)  
 3: { In Cownsayle and Nobilitie I prevayle. (Δ: Pointing to the other of the  
 two uppermost: which is on the right hand.)  
 4: The Gayne and Trade of Merchandise is in my hand: Lo, here it is.  
 Δ: he pointed to the great table on the right side of the myddle Table,  
 that I meane which is opposite to our right hand while we behold  
 those 7 Tables.

Δ I mar-  
 vayle that the  
 earth and waters are  
 both ascribed to one.

5: The Quality of the Earth, and waters, is my knowledge,  
 and I know them: and here, it is. (Δ: pointing to that on  
 the right hand: of the two lowermost.)  
 6: The motion of the Ayre, and those that move in it, are all  
 known to me. Lo here they are. (Δ: pointing to the other Table  
 below, on the left hand.)  
 7: I signifie wisdome: In fire is my Government. I was in the be-  
 gynning, and shalbe to the ende. (Δ: pointing to the great table  
 on the left hand of the Middle Table.)  
 Mi: Mark these mysteries: For, this knowne, the State of  
 the whole earth is known, and all that is thereon.  
 Mighty is God, yea mighty is he, who hath Composed for ever.  
 Give diligent eye. be wise, mery, and pleasant in the  
 Lorde; in whose Name, NOTE,  
 Begynne the Middle Table *∅c*. Δ: I wrote oute of the  
 stone the whole 7 Tables (as you see them here with theyr numbers  
 and letters) while E.T. did vew them in the stone, and orderly express them.

Δ: As concerning 39 V . 47 L *∅c* in the second Table, where are 7 places  
 and there but 6 numbers and letters, and yet every place semeth to  
 have a letter, in the judgment of E.T. his sight. Which is the  
 Number and letter wanting, and where must it be placed?

Mi: *Non potestis hoc videre sine ratione.*

Δ This I inter-  
 sert now;  
 though it wer  
 not at the  
 first Noting.  
  
 two numbers and  
 two letters cuppled  
 to them.

Δ: The Next day, as I was loking on the Tables being finished, and joynd  
 all to gither in One Compownd Figure, E.T. cam to me, and  
 stode by me, and his ey was on the forsaid place which I was forced to  
 leave empty, in the 7th and last. And behold he saw hovering and  
 hopping in the ayre, ∴ over the sayd place, and the next before it.  
 And that, which I had placed the sixth, was to be put in the seventh  
 place, and that which was wanting, was to be set in the sixth place  
 being 30 N.

E.T: Every of the 7 Tables, as they wer written out of the stone  
 do seme afterward to burn all in fyre: and to stand in fyre.

E.T: After all the Tables wer written, eche toke hir Table aparte agayn  
 and stode in theyr order.

E.T: Note moreover. The First, had Bokes in hir hand.  
 Kings ————— The second, a crown in hir hand.  
 Nobilitie ————— The Third, Robes.  
 Merchants Δ — *Aqua* — The fowrth, *animal quadrupes vicium omnim colorum.*  
*Terra* — The fifth, Herbes.  
*Aer* — The sixth, a fanne.  
*Ignis* — The seventh, a Flame of fyre in hir hand.

Mi: *Decedite in nomine eius, qui vos huc misit.*  
E.T: Uriel opened a boke in his own hand, and sayde,  
A boke Ur: The Fowntayne of wisdome is opened. Nature shalbe  
knowne: Earth with her secrets disclosed.  
The Elements with theyr powres judged.  
Loke, if thou canst (in the name of God) understand these  
Tables. Δ: No: Not yet.

Ur: Beholde; I teache. There are .49. Angels glorious and excellent,  
Erthly Actions appointed for the government of all earthly actions: which 49 do  
work and dispose the will of the Creator: Limited from the  
beginning in strength, powre, and glorie.  
Practise These shalbe Subject unto you, in the Name, and by Invo=  
cating uppon the Name of GOD, which doth lighten, dispose and  
Cumfort you.  
By them shall you work, in the quieting of the estates, in learning  
of wisdome: pacifying of the Nobilitie, judgement in the  
rest, as well in the depth of waters, secrets of the Ayre, as in the  
bowells and entrails of the Earth.

Ur: Theyr Names are comprehended within these Tables. Lo, he teacheth,  
he teacheth, Lo, he instructeth, which is holy, and most highest.  
Take hede, thou abuse not this Excellency, nor overshaddow it with  
vanitie, But stick firmly, absolutely, and perfectly, in the love  
of god (for his honor) to gither.  
We two to\_gither Be mery in him: Prayse his name. Honor him in his Saints. Behold  
him in wisdome: And shew him in understanding.  
Glorie be to him; To thee ô Lord, whose name perseth through the earth.  
Glorie be to thee, for ever. Δ: *Amen, Amen, Amen.*

Ur: Lo, I will breifly teache thee; you shall know the Mysteries in him:  
and by him, which is a Mysterie in all things.  
The letters are standing uppon 7 equall numbers. The Number before  
them is signifying, teaching and instructing (from the first Table  
to the last,) which are the letters that shalbe joyned to gither:  
beginning all, with B, according to the disposition of the number  
untyll the 29 general names be known. The first 29 are more  
excellent than the rest. Every Name doth consist uppon the quantitie  
of the place: Everie place with addition bringeth furth his name,  
which are 49. ———I have sayde.———

\*Δ  
*Vide ipanum  
Tabulam ho=  
rum 49 nomen  
Collectam, pa=  
gina sequente.*  
The first 29

Δ: I pray you to tell me the first Name. Ur: The first Name is BALIGON.  
\*he ment to E.T. Mi: I have to say to the\*, and so have I done:  
Δ: Now he spake to E.T., of the matter he sware him to, at the beginning of  
this last instruction: and he told me afterward what Michael had willed  
and moved him unto. Wherat he seamed very sore disquietted: and sayd thus to me,  
E.T: He sayd that I must betake my self to the world, and forsake the  
world. That is that I shold marry. Which thing to do, I have no na=  
turrall inclination: neyther with a safe Conscience may I do it, contrary  
to my vow and profession. Wherefore I think and hope, there is  
some other meaning in these theyr wordes.  
E.T. must marry

Mi: Thow must of force kepe it.  
Thow knowest our mynde.  
Δ: *Deo opt Max. omnium honor laus et gloria  
in sæcula sæculorum. Amen.*

Ended, *hora noctis, 11 1/2 circiter.*

Tabula Collecta: 49 Angelorum Bonorum, Nomina continens

per Δ

|    |         |
|----|---------|
| 1  | BALIGON |
| 2  | BORNOGO |
| 3  | Bapnido |
| 4  | Besgeme |
| 5  | Blumapo |
| 6  | Bmamgal |
| 7  | Basledf |
| 8  | BOBOGEL |
| 9  | BEFAFES |
| 10 | Basmelo |
| 11 | Bernole |
| 12 | Branglo |
| 13 | Brisfli |
| 14 | Bnagole |
| 15 | BABALEL |
| 16 | BVTMONO |
| 17 | Bazpama |
| 18 | Blintom |
| 19 | Bragiop |
| 20 | Bermale |
| 21 | Bonefon |
| 22 | BYNEPOR |
| 23 | BLISDON |
| 24 | Balceor |
| 25 | Belmara |
| 26 | Benpagi |
| 27 | Barnafa |
| 28 | Bmilges |
| 29 | BNASPOL |
| 30 | BRORGES |
| 31 | Baspalo |
| 32 | Binodab |
| 33 | Bariges |
| 34 | Binofon |
| 35 | Baldago |
| 36 | BNAPSEN |
| 37 | BRALGES |
| 38 | Bormila |
| 39 | Buscnab |
| 40 | Bminpol |
| 41 | Bartiro |
| 42 | Bliigan |
| 43 | BLVMAZA |
| 44 | BAGENOL |
| 45 | Bablibo |
| 46 | Busduna |
| 47 | Blingef |
| 48 | Barfort |
| 49 | Bamnode |



Coordinatio Angelorum bonorum 49,  
 per Jo: Dée, ita disposita:

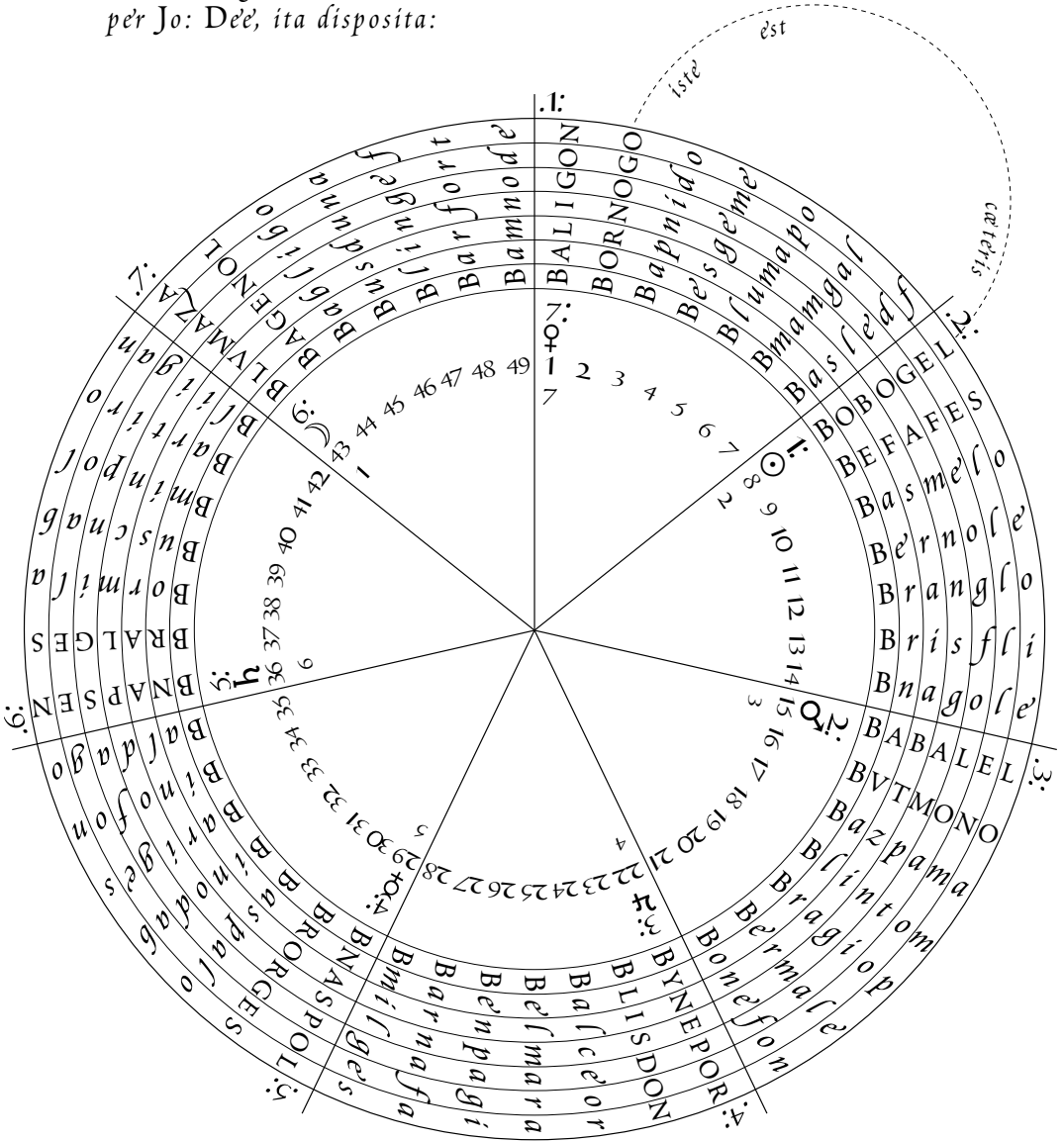



Fryday Maii 4: hor 2 1/2 a meridie

- Δ: E.T. wold not wilingly now deale with the former Creatures, utterly misliking and discrediting them, bycause they willed him to marry. Neyther wold he put of his hat in any prayer to god, for the Action with them: where=uppon I went into my Oratorie, and called unto God, for his divine help for the understanding of his laws and vertues which he hath established in and amongst his Creatures, for the benefyt of mankinde, in his service, and for his glorie &c. And commyng to the stone, E.T. saw there those two, whom hitherto, we wer instructed to be Michael and Uriel.
- E.T.: Michael and Uriel, both kneled holding up theyr hands: and Michael seamed to sweat water abundantly, somewhat reddish or bluddish. There cam 7 Bundells down, (like faggots) from heven ward. And Michael taketh them kneeling. And Uriel taketh a thing like a superaltare and layeth it uppon the Table: and with a thing like a senser doth make perfume at the fowre corners of the Table: the smoke ascending up: and the senser, at the last, being set on the Table it seemed to fall through the Table.
- Uriel his manner of apparition
- E.T.: URIEL semeth to be all in a white long robe tucked up: his garment full of plights and seemed now to have wyngs. (which, hitherto, from the begynning of these kinde of Actions he did not) and on his hed a bewtifull crown, with a white Cross over the Crown. Uriel taketh the .7. Bundells from Michael: and with reverence layeth them on the forsaid Superaltare.
- A Glorious man
- E.T.: There commeth a man, as though he were all of perfect pure glistring gold: somtyme seeming to have One eye, and somtyme Three. From under the Table commeth a great smoke, and the place semeth to shake. Uriel lieth now prostrate on his face: and Michael contynually prayed sweating. The Glorious man seemed to open the Covering of the .7. bundells (being of diverse cullored sylk,) and there appered, that these Bundells seemed to have in them, of all Creatures some, in most glorious shew.
- All creatures
- The glorious man seemed to stand uppon a little hill of flaming fyre. He taketh of, of one of the Bundells a thing lyke a little byrd, and it hoovereth affore him as though it had life: and than it rested upon the thing like a superaltare.
- A description of the glorious man.
- This glorious man seemeth to be open before, and his brest somewhat spotted with blud. He hath a berd forked of brownish cullour, his heare of his hed, long, hanging down to his sholders: but his face, for beutifull glittring, can not be discerned. His heares do shake, as though the wynde carryed them. This man blesseth the bird, making a Cross over it: and so he did three tymes. He looketh up to heven.
- Many cullors in all his garments are shewed in sequentibus libris
- Now the byrd, which, before, seamed to be but as byg as a sparrow, seameth to be as great as a swanne: very beutifull: but of many cullours. Now looketh Michael up, and held up his hands to heven, and sayeth, *Sic, Sic, Sic, Deus noster.*
- Uriel, (sayd)-- *Multiplicabit omnia, benedictione sua.*
- The former Bewtifull man taketh this fowle, setteth it on the bundell, and on the place, from whence it was taken: And, now, the place



where this byrd stode before, seemeth allso to be (proportionally) waxed big, as the byrd, (thus enlarged).

The Yoaking  
or cuppling of  
the two byrds.

This man taketh an other byrd, and putteth the wyng of it, behind the wyng of the first (as though he yoked them.)

This second byrd, at this his first taking, was as byg, as the first was become, (encreased, as it shewed), and it was allso a very bewtifull one.

E.T: All is suddenly dark, and nothing to be seen, neyther Chayre, nor anything els.

E.T: A voyce was hard, like Michael his voyce, saying, It was a byrd, and is a byrd, absent there is nothing but Quantitie.

Δ  
E.T. sayd the  
voyce to be  
like Michael  
his voyce.  
Necessitie.

A voyce: Beleve. The world is of Necessitie: His Necessitie is governed by supernaturall wisdome, Necessarily you fall: and of Necessitie shall rise agayne. Follow me, love me: embrace me: behold, I, AM.

E.T: Now all the Darknes vanished, the man is gon. Uriel standeth at the Table, and Michael sitteth now in his Chayre: and sayd,

Mi: This doth GOD work for your understanding.

vayne to stryve

It is in vayne to stryve: All Government is in his hands. What will you els, what will you els?

Δ: *Progressum et profectum in virtute et veritate ad Dei honorem et gloriam.*

Δ  
forte your

Mi. This hath answered all [y]our Cavillations.

Δ What hath answered all our Cavillations?

Mi. Thow hast written.

One thing you shall see more, as a persuasion to the Infirmities.

E.T: The two byrds, which were there, before, and gon out of sight, now are shewed agayn: but none of the bundells appere.

They seme to grow to a huge bignes, as byg as mowntaynes: incredibly byg: and they seeme to hover up in the ayre, and to fly up toward heaven, and with theyr wyngs to towch the sky: And one of them with his bill seemeth to take sterrs into it: and the other bird to take them from the same byrd, and to place them agayn in the skye.

The byrds towch  
the sky and  
sterrs

And this they did very often: and in diverse places of the heaven with great celeritie.

After this they semed to fly over Cities, and townes, and to break the clowdes in peces, as they passed: and to cause all dust to flye from all walls, and towres, as they passed, and so to make them clene.

And in the streetes, as these two Byrds flew, seemed diverse brave fellows, like bisshops, and Princis and Kings, to pass: and by the wyngs of these byrds, they were striken down. But simple seely ones, like beggers, lame and halt, childern, and old aged men, and wemen, seemed to pass so quietly, untowched and unoverthrown of these two Byrds.

And than they seemed to come to a place, where they lifted up, with the endes of theyr wyngs, fowre Carkasses of dead men (owte of the grownde) with crownes on theyr heds: wherof one seemed to be a Childe.

First these 4, seemed leane, and deade: Then they seemed quick and in good liking: And they being raysed up: parted eche from the other, and went into 4 sundry wayes, Est, West, North and Sowth.

Great Hill

Now these two fowles having theyr wyngs joyned together, light upon a great hill: and there the First fowle gryped the erth mightlyly and there appeared diverse Metalls, and the Fowle spurned them away, still.

Then appeared an old mans hed, heare and all, on; very much wythered. They tossed it betwene them, with theyr feete: And they brake it: And in the hed appeared (in steede of the braynes) a stone, rownd, of the bignes of A Tennez ball of 4, cullours, white, black, red, and greene.

One of them (he that brake the skull), putteth that rownd stone to the others mowth or byll.

**G**

The other eateth or nybbleth on it, and so doth the other allso.

Now these two byrds, are turned into men: And eche of them have two Crownes like paper Crownes, white and bright, but seeme not to be sylver. Theyr teeth are gold, and so likewise theyr hands, feete, tung, eyes, and ears likewise All gold.

26

Crownes

On eche of these two men, ar 26 Crownes of Gold, on theyr right sholders, every of them, greater then other.

They have, by theyr sides, Sachels, like palmers bags, full of gold, and they take it oute, and seemed to sow it, as corne; going or stepping forward, like Seedmen.

E.T: Then sayd Michael, This, is the ende.

E.T: The two men be vanished away.

Mi: Learne the Mysterie hereof.

Δ: Teache us (ô ye spirituall Creatures.) than sayd Michael,

Mi: Joye and helth give unto the riche:

Open strong locks:

Be Mercifull to the wicked:

Pluck up the poore:

Read unto the Ignorant:

I have satisfied thee: Understand:

Read them over: God shall give thee some light in them. I have

satisfied thee: Both, How you shalbe joyned,

By whome,

To what intent, and purpose:

What you are,

What you were,

What you shalbe, (*videlicet*) in Deo.

Lok up this Mysterie:

\*to ET

\*Forget not our Cownsayle:

Ô GOD, thow openest all things: Secret are thy Mysteries  
and holy is thy name, for ever,  
The vertue of his presence, here left, be  
amongst you.

Δ: Amen.

Δ: What am I to do, with the wax, the Table, the ring or  
the Lamine? &c.

Mi: When the things be ready, then thow shalt know, how to use them.

Δ: How shall I do for the graving of the ring; May not another  
man do it, though, E.T. Grave it not?

Mi: Cause them to be made up, (according to instruction) by any honest man.

Δ: What say you as concerning the Chamber, for our practise?  
May my fardermost little chamber, serve, yf the bet be taken downe?

Mi: At the next Call, for the Chamber, you shall know what to do.

Δ: *Benedictus Deus in donis suis:*

*et sanctus in omnibus operibus eius.*

*Amen. ended hor. 4 1/2*



# The Rosie Crucian Secrets

Their Excellent Methods  
of Making Medicines of Metals;  
Also Their Lawes and Mysteries

## THE PREFACE<sup>60</sup>

The Contemplative Order of the Rosie Cross have presented to the world Angels, Spirits, Planets and Metals, with the times in Astromancy and Geomancy to prepare and unite them telesmatically. The Water is not extracted by the hands of men, but it is made by nature a Spermatick, Viscous Composition of water, earth, air and fire, all those four natures united in one crystalline, coagulated mass.

By Mercury I understand not Quicksilver, but Saturn philosophical, which devours the Moon and keeps her always in his belly. By Gold I mean the Spermatick Green Gold<sup>61</sup>, not the adored lump which is dead and ineffectual<sup>62</sup>. This is the substance which at present is<sup>63</sup> our study. [It] is the child of the Sun and Moon<sup>64</sup>, placed between two fires, and in the darkest night receives a light from the stars and retains it. The Angels or Intelligences are attracted by an horrible emptiness<sup>65</sup> and attend the Astrolasme for ever. He hath in him a thick fire by which he captivates the thin Genii. At first the Telesma is neither metal nor matter, neither solid nor fluid, but a substance without all form but what is universal<sup>66</sup>. He is visible and a fume of Mercury, not crude but cocted. This fume utterly destroys the first form of Gold, introducing a second and a more noble one. He hath no certain colour, for Camelion like, he puts on all colours, and there is nothing in the world hath the same figure with him when he is purged from his accidents. He is a water coloured with fire, deep to the sight and, as it were, hollow and he hath something in him that resembles a commotion. In a vaporous heat he opens his belly and discovers an airy heaven, tinged with a milky white light; within this Coelum he hides a little Sun, a most powerful red fire sparkling like a Carbuncle, which is the red Gold of the Rosie Crucians.

That you may know the Rosie Crucian philosophy, endeavour to know God Himself, the worker of all things, and to pass into Him by a whole image of likeness (as by an essential contract and bond), whereby we may be transformed and made as God, as the Lord spake concerning Moses, saying, I have made thee the God of Pharaoh<sup>67</sup>. This is the true Rosie Crucian philosophy of wonderful works, that they understood not, the Key whereof is Intellect<sup>68</sup>. For by how much the higher things we understand, with so much the sublimer virtues are we endowed, and so much greater things do work and the more easily and efficaciously. But an Intellect being included in the corruptible flesh, unless it shall exceed the way of the flesh and obtain a proper nature, cannot be united to those virtues (for like to like) and is, in searching into the Rosie Crucian secrets of God and nature, altogether inefficacious. For it is no easy thing for us to ascend to the Heavens, for how shall he that hath lost himself in mortal dust and ashes find God? How shall he apprehend spiritual things that is swallowed up in flesh and blood? Can man see God and live? What fruit shall a grain of corn bear if it be not first dead; for we

must die to the world, to the flesh and [to] all [the] senses and to the whole man animal, who would<sup>69</sup> enter into the closest of secrets, not because the body is separated from the Soul, but because the Soul leaves the body, of which death St Paul wrote to the Colossians, Ye are not dead and your life is hid with Christ<sup>70</sup>. And elsewhere he speaks more clearly of himself, I know a man, whether in the body or out of the body I cannot tell, God knows, caught up into the third Heaven<sup>71</sup>, etc. I say by this death, precious in the sight of God, we must die, which happens to few, and not always, for very few whom God loves and are virtuous are made so happy. And first those that are born not of flesh and blood but of God; secondly those that are dignified by the blessed assistance of Angels and Genii, the power of Nature, [the] influence of the planets and the heavens and [the] virtues of the figures and Ideas at their birth<sup>72</sup>.

### **Behold The Rosie Crucian Crowne**

This Crown<sup>73</sup> is set with seven Angels, seven Planets, twelve Signs, seven Rulers, twelve Ideas and sixteen Figures<sup>74</sup>.

Observe this harmony. The seven Angels guide the seven Planets, the seven Planets move continuously in the twelve Signs, the seven Rulers run in the twelve Ideas over the face of the Earth, and with the Elements project sixteen Figures. These have their influence upon the seven metals which you must prepare for the Diseases of mankind, as for example, if Mars cause the disease, Venus and Kedemel will cure it and you must make your Medicine of Copper.

If Saturn and Zazel cause the disease, Jupiter and Hismael in Tin prepared will lend you their influence to cure the party<sup>75</sup>. If Saturn cause the disease the Sun and prepared Gold will cure the disease.

Now I will demonstrate in what thing, of what thing or by what thing is the Medicine or Multiplication of Metals to be made. It is even in the nature, of the nature and by the nature of metals, for it is a principle of all philosophers that Nature cannot be bettered but in his own nature<sup>76</sup>.

Trevisan saith: Every Substance hath his own proper and principal seed of which it is made. A pear tree bringeth forth a pear and an apple tree an apple, and God said in the beginning, let everything bring forth his fruit and let the seed be multiplied in itself. And Arnoldus de Villa Nova saith: Every seed is correspondent to his seed and every shrub bringeth forth his proper fruit, according to his kind, for nothing but man is engendered of man, nor of the animals but their like; whereupon Paracelsus concludeth thus: True Alchemy, which only alone teacheth the Art to make Sol and Luna of five metals, will not admit any other receipt because<sup>77</sup> that which is thus (and it is truly spoken): perfect metals are made only of metals, in metals, by metals and with metals for in some metals is Luna and in other metals is Sol. If this be true that in Metals are their seed whereby they may be multiplied, how is it then that the philosophers say their Gold and Silver are not common Gold and Silver, for common Gold and Silver

are dead but their Gold and Silver liveth. To this I answer, common Gold and Silver are dead except they be revived by art, i.e., except their seeds, which are naturally included in them, be projected into their natural earth, by which means they are mortified and revived like as the grain of wheat that is dead and unapt to increase, except by art and industry of man it is in due season sown in his kindly earth and there putrefied and again revived and multiplied. For which cause Trevisan hath written that the vulgar bodies that Nature only hath perfected in the mine are dead and cannot perfect the imperfect bodies. But if we take them and reiterate perfection upon them seven, ten or twelve times<sup>78</sup>, then will they tinge infinitely, for then are they entering, tincting and more than perfect and quick in regard of that which they were before.

Paracelsus likewise affirmeth metallic spirits are dead and lie still so that they cannot work, unless by art they are revived, which thing Arnoldus verifies. Gold and Silver, therefore, simple and absolute in their bodily and metallic form, are dead, but by art they are revived and made Gold and Silver of the Philosophers. And they are revived and brought to yield their seed by reducing them into their first matter, which is called *prima materia metallorum*<sup>79</sup>, for it is impossible for the species or forms of metals to be transmuted but by reducing them into their first matter.

Now the first matter of metals is Argent vive, i.e., Quicksilver<sup>80</sup>, as all philosophers verify. For the first matter of anything is the self same thing into which it is resolved as snow and ice are resolved into water, which is the proper and first matter, and so metals are dissolved into Argent vive. Therefore Argent vive or Mercury is the first matter of metals<sup>81</sup>. Therefore metals of necessity must be reduced into Mercury and not into cloud water as the philosophers affirm, but into a viscous water<sup>82</sup> which is the first matter of metals, for it is the opinion of Paracelsus, Arnoldus and Trevisan that labour is lost which is spent in the Separation of the Elements, for nature will be severed by human distinction, but hath her own separation in itself. Therefore metals should not be reduced into cloud water but into a viscous water.

Albertus Magnus saith the first matter of metals is Argent vive, which is a viscous, incombustible moisture commixed in a strong and wonderful mixture with a subtile earthliness in the mineral caves of the earth, which continually moveth and floweth because successively one part hath rule over another. As the cause of flowing and moving is by moisture bearing the chief rule, so<sup>83</sup> terrestrial dryness bearing chief rule over the action of moisture is the cause it will not stick to that which it toucheth nor moisten [it].

Trevisan saith that is the nearest matter of metals whose viscous moisture is mixed with his subtile earthliness.

And Geber saith, we could never yet find anything permanent in the fire but this viscous matter or moisture which is the self same note<sup>84</sup> of all metals, and all the other moistures<sup>85</sup> do easily fly from the fire by evaporation and separation of one

element from another, as water by fire, one part going into smoke, another into water, another into earth remaining in the bottom of the vessel; but the viscous moistness that is to say Mercury, is never consumed in it nor separated from his earth nor from any other his element; for either they remain altogether or vanish altogether, so that no part of the weight may perish.

Geber thus describeth the nature of Quicksilver<sup>86</sup>: Argent vive, which the Alchemists call Mercury, is nothing else but a viscous water in the bowels of the earth, of a moist and subtile substance of white earth united altogether by a moist, temperate heat by the least parts, until the moist be tempered by the dry and the dry by the moist, so that being thus both equally united and mixed, neither of them may be separated nor taken from one another by the fire. And in this Argent vive, the mother of all metals, is only the whole perfection, for it hath in its composition sulphury parts dry, the which tinge and colour<sup>87</sup> [the] whiteness in act and redness in power, and therefore this is the true Sulphur which perfecteth, formeth, coagulateth, coloureth and fixeth by his action. But this incombustible, hidden and unknown Sulphur which is in power in Argent vive, cannot bring itself forth into act but by due decoction, wherefore you may now perceive that neither nature in the veins of the earth nor we above ground, have any<sup>88</sup> other matter to work upon but only pure Mercurial Form<sup>89</sup> wherein Sulphur is enclosed, that is to say fire and air, which indeed is the internal and essential part of the Mercury itself; but it doth not dominate therein but by the means of heat, the which is caused by the reflexion of the fiery sphere which encloseth the air, and also by<sup>90</sup> the continual and equal motion of the heavenly bodies, which do stir so lent an heat as that it can hardly be perceived or imagined. And thus by most perfect decoction, and also by continual proportional digestion in long success of time is introduced in art and made manifest in the end of the operation of Nature that aforesaid unknown and incombustible Sulphur, which is the true form and ferment of Gold. And thus mayest thou see that metalline form[s] take their original only of pure mercurial substance, the which is the mother of all metals and coupleth and is united with her male, that is with the said Sulphur, the father of metals, the which causeth the diversity of metals according to the different degrees of decoction and alteration caused in Mercury by his own natural heat of inward Sulphur.

The philosophers do agree that there are<sup>91</sup> in the nature and original of metals two sperms or seeds, the one masculine and agent, which they call Sulphur, the other feminine and patient, which they name Mercury; and these two have the natural conjunction and operation one with another in the womb of the earth, whereby they engender metals of diverse form and quality according to the difference and diversity of their degree of digestion and concoction.

Now I will briefly discover the difference between Sulphur and Mercury, and the beginning and natural generation of them, and then show how they have their natural operation, the one with the other, in the bowels of the earth to be made metals perfect and imperfect.

Sulphur is double in every metal save only in Gold, that is to say external, burning and internal, not burning, which [latter] is of the substantial composition of Argent vive. The Mercury or Quicksilver spoken of is engendered or compounded in the bowels of the earth of clear, viscous water by a most temperate heat, united by the least parts, indissoluble, with an earthly substance, incombustible Sulphur, white, most subtile in art, without the which the substance of Argent vive cannot subsist, which coloureth it naturally with a white colour, but in our magistry it maketh it white and red as we will by governing the nature of it; wherefore Argent vive is the total material cause and total substance of the Philosophers' Medicine, containing in itself that internal Sulphur, being a simple fire, lively, quickening, the which indeed is the true masculine agent that before we spake of, the which, by perfect and due digestion and proportional decoction, congluteth, coloureth, formeth and fixeth his own Argent vive into Gold according to nature and to art in the philosophical medicine. But when that Argent vive is by nature thus fixed and made perfect by most high digestion into Gold only by his own proper and inward Sulphur, which is the true ferment, then the external, combustibile Sulphurs cannot enter in nor be mixed with him, but they are<sup>92</sup> parted clear away as the corruptible from the permanent; wherefore they enter<sup>93</sup> not into Gold and therefore cannot be the matter or form, or any part of the matter or form of the Philosophers' Medicine. And thus you may understand the difference between the true Sulphur and Mercury, for when it appeareth simple it is flowing and is called Mercury, and is volatile, carrying or holding his proper incombustible Sulphur or ferment hidden in power. But when in the end of the aforesaid decoction that hidden Sulphur is brought wholly into act, whereby the whole is manifest and doth show the nature of Sulphur, then it is called Sulphur, which doth coagulate, reduce and fix his Argent vive to his proper nature, which is to be made Gold. Wherefore this is the only tincting Sulphur of the philosophers, the which is unknown to the common people. But the compound of them is called the Mixed Medicine, perfect and sound, and in the commixtion they are made all one as wax, and so in truth you may now see that these two spermatick matters are of one root, substance and essence, that is to say of the only essence of pure Argent vive. But the diversity of the sundry shapes, forms and bodies of metals, the which is the cause of the perfection or imperfection of them, is according to the diverse and several degrees of alteration caused by their decoction and digestion. For the Mercury, [which] is Argent vive running in the veins of the earth, conjoineth and is mixed with the aforesaid external Sulphur, and being so mingled and conjoined together by the sundry and different degrees of the decoctions of the internal Sulphur caused by the motions of the heavenly bodies, there is engendered the sundry shapes and forms and bodies of the metals in the entrails of the earth<sup>94</sup>. For first in the first degree of natural operation and digestion, the heat of the internal Sulphur working and somewhat prevailing in the humidity of his Mercury, beginneth somewhat to fix and coagulate the mercurial humour and giveth it the form of Lead. And by further digestion and decoction, the Sulphur yet somewhat more prevailing over his Mercury, the Mercury is somewhat more fixed and receiveth the form of Tin.

Then doth the heat dominate more and maketh Copper and then Iron, and further proceeding in their digestion, the internal Sulphur yet more subduing the moist[ure] and cold of his Mercury by a temperate heat, and attaining by his concoction purity and perfection of whiteness, it more firmly fixeth his body and giveth it the form and fixation and tincture of Silver. And now the essence that was in power is brought forth into act, whereby the external, earthly Sulphur, which gave a transitory form to the undigested metals, is almost utterly expoliated and separated by reason of his perfect form introduced by the means of our digestion and proportional decoction.

And yet in the Silver there are some small parts of the external Sulphur, the which are by the last and most temperate, complete digestion of nature wholly and thoroughly expoliated. And then by nature is accomplished the most perfect, simple and pure substantial form of Gold, which Gold in the perfection of his metalline nature is pure fire, digested by the said Sulphur existing in Mercury, whereby his Mercury, that is to say his whole substance, is converted into the nature of his pure Sulphur and made permanent and triumphant in the force and violence of the fire. And by separation of the external Sulphur, the metals are made perfect according to the<sup>95</sup> divers degrees of their decoction, digestion and alteration, wherein they separate themselves from the earthly and combustible Sulphur and attain their true, complete, pure form and fixation.

But whereas the philosophers do seem to set down by degrees first Saturn, then Jupiter, then Luna, then Venus, then Mars and then Sol, they had a further meaning therein which is not to be understood according to the letter; for indeed Venus and Mars are placed after Luna, not that it should be believed that Luna doth turn or go into an imperfect body as Venus and Mars, but in truth they are placed after Luna for two causes, first because of the over great and excessive burning of the filthy and fixed, earthly, external Sulphur, which is joined with their Mercury and is outwardly by too much intemperate and an overgreat, superfluous, drying, combustible heat, coagulated and decocted with the Argent vive to a corruptible body, while the other cause is philosophically to be understood in the order and degrees of the colours<sup>96</sup> in the working of the Philosophers' Medicine, which is a similitude and analogy, and this over great quantity of burning, gross, earthly, external Sulphur is the cause of the hard melting of Mars. But so soon as nature by a temperate, complete digestion hath introduced into act the internal, pure Sulphur, then are separated all those external Sulphurs from the Mercury and a perfect form is introduced. [An] example [of this is to be seen] in the projection of the Philosophers' Medicine, which, being cast upon imperfect metals molten, doth only by virtue of the most pure, temperate, high and mighty digestion fix and give a true, natural form to the Mercury of the bodies, whereby is expoliated away all external Sulphur and they are perfected into fine Gold. And you must also know that nature doth not always [proceed by means] of these degrees in passing through the dispositions and paths<sup>97</sup> of the metals, or any one of them, but doth oftentimes engender perfect Sol as the aforesaid beginning by a most temperate and due decoction in the

bowels of the earth. The reason hereof, the knowledge of the countries and mines will make manifest unto you<sup>98</sup>.

And thus have I made plain the very operation and work of nature in the earth, as all the philosophers deciphered it. And this operation of nature are we to imitate and follow as near as possible in our art, according to the earnest precepts and prescriptions of all the philosophers in this behalf.

Now I shall show how and in what manner our art must imitate the operation of nature; but first I will resolve, wherefore do the philosophers call Mercury or Quicksilver the First Matter of Metals, when there is another matter or sperm, as we have declared, which must be joined with it before metals can be engendered.

The philosophers do truly call Mercury the First Matter of Metals, being so indeed, for the Sulphur which is the masculine sperm, is of her, and she is the root of him and his coagulation, as Hermes said. And also the same man saith, this water coagulateth when it is congealed and running water is the mother of that which is congealed and coagulated and so it was ever. For which cause the philosophers call the feminine sperm the patient, or matter which suffereth the action of her agent, and taketh the impression of his forms in her substance; and therefore the philosophers said truly that Sulphur giveth the form and beginning of being more than matter, when as that it is his act and matter power and form; for according to the truth of forms, they are named the substance of things, but matter may after another sort be called more the substance in as much as it is the beginning to everything, and from it are extracted all forms.

If, therefore, any man would like to know the form of Gold, he must of necessity know the matter of Gold, the which is Argent vive. It springeth flowing, liquid, flying, bright and suffereth coagulation, and is, therefore, truly called the First Matter of Metals, because all metals have their first matter or substance from her, their mother, the forms of the metals being affected by the moving of the active elements, fiery and airy, of Mercury, that is to say, Sulphur<sup>99</sup>, the which moveth Argent vive, as this proper matter for generation into metals, according to the degrees of his motions.

Now we proceed to apply the operation of an art to the operation of nature, and show what is the first work of art.

Learn to know what is the first work of art by the first work of nature, always provided that it be that first work of nature that art is able to perform. But because the first work of nature was to make the two sperms of nature, which art cannot do, therefore the second work of nature, which is the conjunction of the two sperms in one, must of necessity be the first work of art, and the creation or making of the two sperms must be the only referred to nature, who hath provided and prepared to art the matter that art is to work upon. According to the saying of

the philosopher, art of itself cannot create the sperms, but when nature hath created them, then doth art, joined with that natural heat which is in the sperms already created, mix them as the instrument of nature, for it is plain that art doth add neither form, nor matter, nor virtue, but only aiding the thing existing, to bring it to perfection. And again, nature hath created a matter unto art, unto which art neither addeth anything nor taketh anything away, but removeth such things as are superfluous; likewise nature hath provided for us one Stone and one matter and one medicine, unto the which we, by our art, add no foreign thing, nor in any point diminish it, but in removing that which is superfluous in the preparation<sup>100</sup>, and this is done in the purification which is effected by solution. By these words it plainly appeareth that nature hath prepared the matter wherein art is to work, and art by no means can make the same matter; but the only work of art is to cleanse and purify that which nature hath left impure, and make that perfect which nature hath left imperfect, as is verified by this last saying of Arnoldus, and that first of Trevisan.

Now, therefore, it follows that the first work of Art, wherein art doth imitate nature, must of necessity be that which is the second work of nature, (*viz.*) as the second work of nature after she had created the sperm was to join these two sperms of nature together, whereby to make the First Matter of Metals, so the first work of art must be to conjoin the sperm of metals together, whereby we must make the First Matter of one pure Medicine, that may bring the impure and imperfect metals into the purity and perfection of nature. And this can no otherwise be done but by reduction of them into their First Matter as is before said, by which means we may have (as Arnoldus saith) the same sperms of the metals above earth that nature did work in under the earth. And this reduction is nothing else but the dissolution in which they are dissolved into the natural Mercury and Sulphur again, but more pure than they were before by reason that they are in their dissolution separated and purified from the fex and impurity of their nature and make more pure and perfect whereby to engender a more pure and perfect matter than nature could do; and for this cause hath the philosopher written this conference in the lamentation of nature between nature and art, 'Without me, which do yield the matter, thou shalt never effect anything, and without thee also, which dost minister unto me, I cannot alone finish this work.'

It is the chiefest and highest secret of the philosophers to know out of which of the metals must we have these sperms. I ought not to disclose the same in plain terms, but in dark speeches and figures as they have done. Notwithstanding, mark that which shall follow and I will discover to thee the secrets of the philosophers in hope that thou wilt hide them in thy heart and commit the papers to the fire. Now first and chiefly thou must call to remembrance the words of the philosophers before named, who say that in some metals is Sol and in some metals Luna. That is to say, in some metals is the masculine sperm and in some is the feminine sperm. In some of the metals is the tincture of Gold and in some of the metals is the tincture of Silver. Some of them are masculine and some are feminine. For that these words are true in their expositions, the words of Hermes

do very well prove, who said Red Sol is his father and White Luna his mother<sup>101</sup>. If, therefore, Sol be the father and Luna the mother, and in some of the metals be Sol and in some Luna, what is this but to say that some of the metals are masculine and some of them feminine, or in some of them is the masculine sperm and in some of them is the feminine sperm. Now, therefore, consider which of them are the masculine bodies, and out of which the masculine sperms are to be had, and then we shall more perfectly discern the feminine bodies whence the feminine sperms are to be fetched.

Note that the philosophers do diversly name these two sperms. The masculine they call agent, the Sulphur or renet, the body or ferment, the poison or flower of Gold, the tincture or inward fire and the form. The feminine sperm they call the patient, Mercury, the Spirit volatile, Argent vive, *menstruum*, water, azoth and the matter and by many other names they name them both. But this *caveat* in the discerning of them I give thee for three causes especially. The one is because thou shouldest in reading of the philosophers not mistake any one of them for the other; the second cause, that thou shouldest by these names know which of the metals are masculine by the quality of their names; and the third cause is that thou shouldest thereby gather and understand that the two sperms, being of two several natures and qualities, can by no means be fetched from one body, as divers have misconstrued, no more than both the sperms of man and woman are in man alone. But they are to be had of two substances of one root, as Trevisan, Arnoldus and the rest of the philosophers affirm.

But I will give thee this secret note, that the two sperms must be had out of two several bodies, yea two bodies in one only root, which is the same Hermaphrodite of the philosophers, which they often write of<sup>102</sup>, or their Adam<sup>103</sup>, as in due place shall be disclosed; but in all the reading of the philosophers keep well this *caveat* in thy mind, of the several names and natures of the two sperms.

But now I shall proceed to prove by the philosophers which are the masculine bodies, and how a question shall arise whether is that which giveth the form or tincture the masculine sperm or the feminine. You need not to doubt that among the metals Sol and Luna are both agents and masculine sperms<sup>104</sup>, for they both give form and tincture severally, the one to the white work, the other to the red work, according to the sayings of the philosophers.

For Arnoldus in his *Rosary* saith Gold is more precious than all other metals and is the tincture of redness tincting and transforming every body, but Silver is the tincture of whiteness, tincting all other bodies with a perfect whiteness; and therefore he which knoweth to tinct Argent vive with Sol and Luna cometh into the secret. Likewise in another place he saith thus. The first work is to sublime Mercury and to dissolve it, that it may return into the First Matter. Then let the clean bodies be put into this clean Mercury, but mix not the white body with the red, nor the red with the white, but dissolve every one severally apart, because the white water is to whiten and the red water is to make red, therefore mix not

the water of the one medicine with the water of the other, because thou shalt greatly err and be blinded if thou do otherwise. By those two sentences of Arnoldus it appeareth not only that Sol and Luna are agents, the one giving form to the red work, the other to the white, but also there is another body that is to be dissolved into Mercury, which is the patient of these two, for as much as those two are to be put into the same; yet it is not the patient to them both together, but each of them severally and assunder, which proveth them plainly to be both masculine and agent, and none of them patient to any other, nor by any means to be mixed one with another, but a third thing to be patient to them both, that is to say the same Mercury or Argent vive that they before spake of where they said that he which knoweth how to tinct Argent vive with Sol and Luna cometh to a secret<sup>105</sup>. Likewise the noble Trevisanus saith, Our medicine is made of two things, being of one essence, to wit of the union mercurially of fixed and not fixed, spiritual and corporeal, cold and moist, hot and dry, and of no other thing can [it] be made. By those words it is manifest that the two Mercuries whereof our medicine is to be made are both of one root but of contrary qualities; that is to say, the one is Mercury fixed, the other not fixed; the one a corporeal, the other a spiritual; the one hot and dry, the other cold and moist; which several Mercuries are contrary, and contrary matters cannot be included in Sol and Luna. For they, as Agents, are only hot and dry, corporeal and fixed, but they are not, as patients, cold and moist, volatile or spiritual<sup>106</sup> and unfixed, and therefore in them may be the masculine sperm, but in no wise the feminine; and therefore, saith *Turba [Philoso]phorum*, a tincture proceeding from the fountain of Sol and Luna giveth perfection to imperfect metals, upon which considerations they have also set down this most excellent canon and principle, (*viz.*) the secret of all secrets is to know that Mercury is the matter and *menstruum*, and the matter of perfect bodies is the form. What is this but as who should say, seeing the Mercury drawn from the perfect bodies is the form or agent sperm of our medicine, then Mercury of an imperfect body must needs be the matter or feminine sperm<sup>107</sup>; to the confirmation whereof Paracelsus saith thus: Philosophical Mercury that is of Sol, is in the conjunction compared unto the corporeal spirit of Mercury, as is the husband to his wife whereas they are both one, and the self same root and original, although the body of Sol remains fixed in the fire but the metallic woman unfixed. Notwithstanding *that*, compared to *this*, is no otherwise than the seeds to the field or earth.

By these words of Paracelsus it is evident that the difference between the metallic man and the metallic woman is that the metallic man is fixed and the metallic woman unfixed; by which means it is plain that this metallic woman cannot be Silver or the Spirit of Silver, as some do fondly surmise, and as the most do take it, but of some imperfect body that is unfixed. For who is so simple but knoweth that Luna is fixed and permanent in the fire and inseparably united with his pure white Sulphur.

Then it is proved the two perfect bodies are the agents, giving the forms and tinctures, and so, consequently to be the masculine sperm<sup>108</sup> and no less proving

that the feminine sperm is to be had from an unfixed body, of which nature neither of them is, and therefore we must yield to the apparent reasons and authority of the philosophers.

I shall now expound by some of the philosophers the saying of Hermes that his father is Sol and Luna his mother.

These words of Hermes, though they be so full of truth and have no deceit in them, yet a great number have been deceived thereby. The cause of their error is because they do not consider the nature of Luna, which they take to be meant of Hermes to be the mother of our matter. For if they did either consider the masculine property of Silver or perused the philosophers touching their construction of this point, they should well perceive that Luna is not the Silver<sup>109</sup> that Hermes meaneth, but a certain unfixed matter or Mercury, of the nature and quality of the Celestial Luna<sup>110</sup>, as in the *Canons of the Philosophers* appeareth, and in the *Turba [Philoso]phorum* by these words: It is a thing worthy to be noted that Luna or Silver is not the mother of common Silver, but it is a certain Mercury endued with the nature and quality of the Celestial Moon, which is the same Mercury or woman before spoken of, that is not fixed as Silver is, but is the nature of the Celestial Moon in respect of her moist, unmixed<sup>111</sup> and watery quality, having her fixation, form and tincture of her Sulphur as the Celestial Moon taketh light of the Sun. Therefore out of doubt it must be drawn from a body of the same nature, and not from a body of a contrary quality; for what can be more absurd than to think that an unfixed matter can be in a fixed metal or a fixed nature in an unfixed body. Consequently what can be more evident and manifest, seeing the philosophers do all affirm that the metallic man is fixed and the metallic woman unfixed, than that the fixed sperm must be had of a fixed metal and the unfixed and volatile nature out of an unfixed substance, and, therefore, by no means had from Luna, because of her fixed and masculine nature, which all the philosophers in plain terms confirm to be true, as in their *Canons*, by a question demanded and answered in this manner. The question amongst wise men is, whether the Mercury of Luna joined with the Mercury of Sol may be had instead of the philosophical *menstruum*. The[y] answer, Mercury of Luna doth hold the nature of the male or masculine, but two males cannot engender no more than two females. Likewise in another place thus, the Sulphurs Sol and Luna are the two sperms or masculine seeds of the Medicine. And in the *Turb[a]* thus, metallic Lunes are of a masculine nature. Thus I have proved that the two perfect metals are the two masculine bodies, from which we are to fetch our two masculine sperms or forms or tinctures, i.e., both of the red and white, which, seeing they are fixed and perfect bodies, the form and tincture and agents of our matter, they have sufficient reason of themselves to persuade that they can be no other than the masculine sperms, except we will, contrary to all rule of reason and nature, have one thing both the agent and the patient.

Now I will demonstrate which are the feminine bodies, and out of which the feminine sperms of our matter is to be fetched.

This secret of both these secrets is the greatest and requireth of itself to be kept as secretly in the hearts of all wise men hereafter as it hath been of all ancient philosophers heretofore.

Understand the secret by this figure 3, which number indeed it doth contain in itself, and is the very figure of the Trinity of the Deity.

First I will show the reasons as the marks and tokens whereby thou shalt understand and know that this 3 is the same feminine body where is the feminine sperm of our blessed matter, which I will prove by the authority of the philosophers in this manner. First the philosophers do all agree that the metallic man in our matter is fixed and the metallic woman unfixed. If, therefore, I prove our matter 3 to be unfixed, it is a great argument and probability that our 3 is the same woman.

The second mark and token whereby she is known is that the philosophers agree that their Mercury or water which reduceth their Gold or Sulphur into his First Matter is the same that abideth and is permanent with it as Trevisanus declareth<sup>112</sup>. There is required in our natural solution the permanency of both, viz., of the water dissolving and of the dissolved body; and in another place, no water dissolveth the metallic essence with a natural reduction but that water which is abiding therein in matter and form, which water also, the metals themselves being dissolved, are able to congeal. And Arnoldus saith, the nature of the dissolved body and the dissolving water is all one, but only that the nature of the body is complete, digested and fixed, but the nature of the water is incomplete, undigested and volatile until it be fixed by the body. And in Paracelsus our woman dissolveth her man and the man fixeth the woman. By these words it is plain that the water which dissolveth the body is the same that is permanent with them<sup>113</sup>, that is to say, the woman or feminine sperm that is to be joined with the man or masculine.

Paracelsus saith plainly, speaking in the person of the figure 3, my spirit is the water, dissolving the congealed bodies of my brethren and Raymund Lullius saith in his *Epistle to the King*, Our water, you know, is extracted from a certain stinking *menstruum*, which is compounded of four things, and is stronger than all the water of the world, and it is mortal, whose spirit multiplieth the tincture of the ferment. And in another place he saith, all alchemical Gold is made of corrosives and of an incorruptible quintessence, which is fixed with ferment, but such quintessence is a certain spirit reviving and mortifying the mineral medicine. And *Turba [Philoso] phorum* saith, take the black spirit and with it dissolve bodies and divide them. Now consider the nature of our figure 3, and judge if this be that water or no. It must needs be the same, for the words fit the nature of our figure 3 and no other of the imperfect bodies but her, for all the philosophers agree that she is earthly, dark, cold and stinking, and Paracelsus nameth her plainly, the water dissolving her brethren.

Consider yet another note or mark whereby she is known, as the ancient and modern philosophers do affirm that their Gold must be sown in his own proper earth, as also in the *Turb[a]*, let our Gold be sown in his own proper earth.

Arnoldus in his *New Light* saith, with my own hands, my eyes being witnesses I have made the Elixir that converted Saturn into Sol, which matter truly I have now named, and it is the philosophers Magnesia, out of which they found<sup>114</sup> quicksilver of quicksilver and Sulphur of Sulphur. To construe these words rightly, what is our figure 3 but Mercury of Mercury, and what is our Gold but Sulphur of Sulphur. I will yet impart a greater secret.

It is written by good philosophers and found true infallibly by daily experience, that the figure 3 is never found simple or pure by himself in the mine, but is ever mixed with Gold or Silver, whose grains or seeds in him are plainly to be seen to the eyes; by which means it appeareth that there is no mine of himself, but he is the mine of them and so their very natural earth.

Consider these words following from Flammellus<sup>115</sup>, and thou shalt yet hear a greater secret than these. Mercury being never so little congealed in the veins of the earth, there is straightways fixed in it the grain of Gold which, of the two sperms, do bring forth true springs and branch of Mercury as we may see in the caves of Saturn, wherein there is no mine in any of which the true grain of the fixed may not be contained manifestly, that is the grain of Gold or Silver. For the first congelation of Mercury is the mine of Saturn in which it is put by nature. This may truly be multiplied into his perfections without fail or error, being, notwithstanding, in his Mercury not separated from his mine. For the metal consisting in his mine is Mercury, from which if the grain be separated it will be an unripe apple plucked from his tree, which is altogether destroyed. The fixed grain is the apple and Mercury is the tree; therefore the fruit is not to be separated from the tree, because it cannot elsewhere receive nourishment then from his Mercury. It is as great a folly to put Gold or Silver into Mercury as to fasten an apple again to the tree from whence it was taken. Therefore, that this business might be duly accomplished, the tree together with his fruit must be taken, that again it might be planted, without taking away the fruit, into a more fertile and new soil, which will give more nourishment in one day than the first field would have yielded in an hundred years, for the continual agitation of the winds. Go up, therefore, into the Mountain that thou mayest see the vegetable, Saturnian, royal and mineral herb<sup>116</sup>, for let the juice be taken pure, the feces being cast away, for thereof thou mayest effect the greatest part of thy work. This is the true Mercury of the Philosophers.

Trevisan confirms the matter thus. Our work is made of one root and two substances Mercurial, taken crude, drawn out of the mine clean and pure, conjoined by fire of amity as the matter requireth it, cocted continually until that of two be made one; and in this one, when the two are mixed, the body is made

spirit and the spirit is made body. Paracelsus likewise speaking plainly in the name of our figure 3 saith: It would be profitable to the lesser world<sup>117</sup> if he did know or at least believe what lay hid within me, and what I could effect, for he that doth discourse upon the art of Alchemy would more profitably understand that which I can do if he would use that only which is in me, and that which by me may be done. And in another place, under an enigma, he notably discovereth this our blessed matter where he saith: Whatsoever staineth into a white colour hath the nature of life and the power and property of light, which causally<sup>118</sup> effecteth life; and contrariwise, whatsoever staineth into blackness or maketh black hath the nature common with death and the property of darkness and the strong power of death. The coagulation and fixation of such manner of corruption is the earth with her coldness. The house is always dead, but the inhabitant of the same liveth, and if thou canst find forth the example thereof thou hast prevailed.

By these words it appeareth that as the tincture of whiteness is the cause of life, which is the spirit of generation, so the blackness, which is the spirit of corruption, is death; and these two tinctures are in our blessed herb. The natural blackness whereof, that is to say our figure 3, is the spirit of the corruption or mortification, which is the same earth which he here noteth with his coldness. The same dead house within the artificial digestion is the death and mortification and putrefaction of the matter, and our Silver and Gold, which is naturally included in the same, is the tincture in his first artificial operation according to the philosophers, who say there is no Gold, but first was Silver before it was Gold. This tincture of whiteness is the same inhabitant which liveth in the same dead house, according to the saying before, the house is dead but they live which inhabit it; by which means it is plain that this is the same example which he speaketh of when he saith, the example whereof, if thou be able to find out, thou hast thy purpose.

Arnoldus noteth in his *Rosary*. This we see, that in the calculation of our figure 3, that first [it] is converted into black powder, next into white, then into a more yellow or red, which words very well discover his enigma written of this matter. Elsewhere he saith thus. The thing that hath both a red head, white foot and black eyes is the *materia*. Likewise it appeareth by the enigma of Hermes<sup>119</sup>, The falcon is always on top of the mountain crying I am the white of the black and the red of the citron. Now I will show how there is in our figure 3 that [which] I before spake of; the other thing [is] to show how it is the Hermaphrodite or Adam of the philosophers<sup>120</sup>.

In our mineral herb is the number of 3 thus. First therein is our figure 3. Secondly there is our Sulphur, i.e., our Gold or Silver which is naturally mixed with him. Thirdly there is the root of these two, that is to say Mercury or Quicksilver, whereof they were engendered, and whereunto they must be reduced, in respect of which trinity in unity it representeth the Figure of the Deity. Now of our Hermaphrodite or Adam therein. What else is our mineral herb<sup>121</sup> but one root of two substances, wherein is both our man or woman, that is to say our Gold is our

Man, or sperm masculine, or Silver according to his natural mine, which is also the Sulphur, the tincture, the ferment and form before spoken of, having the perfect and fixed nature of the man, and the two agent elements of fire and air in them, and our woman is our figure 3, i.e., which is the feminine sperm, the patient, the *aqua* the *menstruum*, the matter, the Spirit volatile and the undigested<sup>122</sup> or unfixed body, having in her the two patient elements of water and earth.

Thus you see that Sol and Luna are the masculine sperms in our matter or figure 3, which is also the natural woman, water and earth of them both, where by nature they are planted and spring. That is to say the matter of our red work is our figure 3 joined with Sol and the matter of our white work is our figure 3 joined with Luna<sup>123</sup>, which matters are first to be had for more surety and security of art even in nature itself called *fex plumbi* or *Quehaeli Hispanica*. And thus dost thou see in our blessed matter, 4. 3. 2. and 1., yea and one only thing according to the words of all philosophers, [and] that you may not in the least doubt of the truth hereof, I have truly laid it open. The root of the operation of art in the matter shall hereafter be at large declared.

Commending, for this great and gracious mystery and secret of nature, to the Godhead all eternal glory, to Whom it is due.

The Lord illuminate my heart with His light and truth so long as my spirit remains in me, for His light is very delightful and good for the eye of my soul to see by; for so shall the night be enlightened to me as the day, neither shall the clouds shadow it. It shall not be like the light of the Sun by day because it shall not be clouded, nor like the light of the Moon by night, because it shall never be diminished as her light is.

The sun was made to rule the day and not to give light to it only, as appears *Gen. i*. And the Moon was made to rule the night and not to give light to it only, because she hath no light to give. Also God made the whole Host of Heaven, the fixed stars and planets, and gave them virtues together with the luminaries, but these virtues are not so great as the virtues of the luminaries, neither is the virtue of the Moon so great as the virtue of the Sun, because she borrows her light from the Sun. Also the whole Host of Heaven, that is the fixed stars, move all in the same sphere, and therefore their distance is always the same, but it is not so with the planets, for their course is various and so is their distance the one from the other, and so is their latitude. For some times they are upon the ecliptic, sometimes North from it and sometimes South, sometimes retrograde, sometimes direct, sometimes in conjunction with one another, sometimes in opposition, sometimes in other aspects. The reason of this is because the sphere of one is lower than the sphere of the other and the lower the sphere is, the sooner they make their revolution.

The nearest to the earth of all the planets is the Moon, and therefore her course is swiftest; and besides her difference in longitude or latitude there happen other accidents to her, which are not visible to other planets; for sometimes she increaseth and sometimes decreaseth, and sometimes she is invisible or faileth in light. The reason why the planets are not seen horned as the Moon is because their distance is greater from us. All the planets are seen biggest when they are at their greatest distance from the Sun, or when they are nearest to the earth according to Copernicus. Also sometimes the Moon is eclipsed, but not in the same manner as the Sun, for the Sun never loseth his light but is only shadowed from a particular people or place by the body of the Moon, but the Moon, eclipsed totally, loseth her light and the reason is the Sun's light is his own, but the Moon['s] is a borrowed light. This being premised, I consider all things under the Moon universally, whether men, beasts or planets, are changed and never remain in the same state, neither are their thoughts and their deeds the same. Take council of your head and it will certify you of the truth hereof; and they are varied according to the various course and disposition of the planets. Look upon your own genesis and you shall find your thoughts moved to choler so often as the Moon transits the place where the body or aspect of Mars was in your genesis; and to melancholy when she doth the like to Saturn. The reason is because the Moon is assimilated to the body of man, whose virtue as well as her light increaseth and diminisheth, for she brings down the virtue of the planets to the creatures and to man if he lives upon earth.

The Sun causeth heat and cold, day and night, winter and summer. When he arrives to the house of his honour or exaltation, to wit Aries, then the trees spring, living creatures are comforted, the birds sing, the whole of creation rejoiceth and sicknesses in the body show themselves in their colours. Also when he arrives at his Fall, to wit Libra, the leaves of the trees fall, all creatures are lumpish and mourn like the trees in October. Another notable Rosie Crucian experiment. Usually sick people are something eased from midnight to noon, because the Sun is in the ascending part of the heaven, but they are most troubled when the sun descends, that is from noon to midnight. The course of the Moon is to be observed in many operations both in the sea and the rivers, vegetables, minerals, shellfish, as also in the bones and marrow of men and of all creatures. Also seed sown in the wane of the Moon grows either not at all or to no purpose. The Rosie Crucians have experiences of many virtues of the stars, and have left them to posterity, and have found the changes and terminations of diseases by the course of the Moon. Wherefore the 7th, 14th, 20th or 21st, 27th, 28th or 29th days of the sickness are called critical days, which cannot be known but by the course of the Moon. But rest not in the number of days, because the Moon is sometimes swifter, sometimes slower. As for such diseases as do not terminate in a month (I mean a lunar month, the time when the Moon moveth round the zodiac, which is in 27 days, some odd hours and minutes), you must judge of these by the course of the Sun.

The day is called critical because the Moon comes to the quartile of the place she was in at the decumbiture, sometimes a day sooner or later.

When she comes to opposition of the place she was in at the day of the decumbiture, she makes a second crisis; the third when she comes to the second quartile, and the fourth when she comes to the place she was in at the decumbiture, and then is the danger.

The reason of the difference of the Moon's motion is the difference of her distance from the earth, for when the centre of her circle is nearest to the centre of the earth, she is swift in motion; and hence it comes to pass that sometimes she moves more than 15 degrees in 24 hours, sometimes less than 12. Therefore if she be swift in motion she comes to her own quartile in six days, if slow, not in seven; therefore must you judge according to the motion of the Moon, and not according to the number of days.

Upon a critical day, if the Moon be well aspected with good planets, it goes well with the sick; if by ill planets it goes ill. You must be resolved in one particular which is, if the crisis depended upon the motion of the Moon and her aspect to the planets, what is the reason if two men be taken sick at one and the same time, that yet the crisis of the one falls out well and not so in the other. I answer, the virtue working is changed according to the diversity of the virtue receiving<sup>124</sup>. For you all know the Sun makes the clay hard and the wax soft; it makes the cloth white and the face black; so then if one be a child whose nature is hot and moist, the other a young man and the third an old man, the crisis works diversely in them all because their ages are different. Secondly the time of year carries a great stroke in this business. If it be in the spring time, diseases are most obnoxious to a child because his nature is hot and moist; a disease works most violently with a choleric man in summer; with a phlegmatic man by reason of age or complexion in winter.

If the Moon be strong when she comes to the quartile or opposition of the place she was in at the decumbiture, *viz.* in her house of exaltation, the sick recovers if she be aspected to no planet.

Judge the like of the Sun in chronical diseases, but judge the contrary if either of them be in detriment or fall. If the Moon be void of course at the beginning of a disease, the sign is neither good nor bad. Look then to the sign ascending at the beginning of a disease and let the Moon alone for a time.

Observe the following directions how to prepare all the seven metals. If Mars cause the disease, Venus helps more than Jupiter, that is a medicine of Venus cures. If Saturn, then Jupiter more than Venus, *i.e.*, prepared Jupiter cures.

Whatsoever is said of the Moon in acute diseases will hold as true of the Sun in chronical diseases.

What diseases every planet signifies and the disease that are under the twelve signs, with the parts of the body every planet rules, the cure of those diseases by Rosie Crucian physic, by the seven metallic preparations, shall in his proper place be handled at large.

To unlock this grand Rosie Crucian mystery of the ASTROBOLISMES of metals, the miraculous saphiric medicines of the Sun and Moon, the ASTROBOLISMES of Saturn, Jupiter, Mars, Venus, Mercury.

Seriously consider the system or fabric of this world<sup>125</sup>; it is a certain series *a non gradu ad non gradum*, from that which is beneath all apprehension to that which is above all apprehension. That which is beneath all degrees of sense is a certain horrible, inexpressible darkness. The magicians call it *tenebrae activae*<sup>126</sup>, and the effect of it in nature is cold etc. For darkness is *vultus frigoris*<sup>127</sup>, the complexion, body and matrix of cold, as light is the face, principle and fountain of heat. That which is above all degree of intelligence is a certain infinite, inaccessible fire or light. Dionysius calls it *Caligo Divina*<sup>128</sup>, because it is invisible and incomprehensible. The Jew styles it Ein<sup>129</sup>, that is *nihil* or nothing, but in a relative sense or, as the schoolmen express it, *quoad nos*<sup>130</sup>. In plain terms it is *Deitas nuda, sine indumento*<sup>131</sup>. The middle substance or chain between these two is that which we commonly call nature. This is the *Scala* of the great Chaldee which doth reach<sup>132</sup> from the subternatural<sup>133</sup> darkness to the supernatural fire. These middle natures came out of a certain water, which was the sperm or First Matter of the great world. And now we will begin to describe it: *capiat qui capere potest*<sup>134</sup>.

It is in plain terms Cuton cai Ruton udwr<sup>135</sup>, or rather it is Hcuth<sup>136</sup>, that is Taia cumatwdhs cai to ceisetai ths ghs<sup>137</sup>, an exceedingly soft, moist, fusible, flowing earth, an earth of wax that is capable of all forms and impressions. It is Udramenos ghgeneths, *terrae filius aqua mixtus* (Son of the Earth mixed with Water)<sup>138</sup>, and to speak as the nature of the thing requires, Tewmighs cai ghs gamos<sup>139</sup>. The learned alchemist defines it as qeion argurion zwticon, enwsis twn pneumatun en swma<sup>140</sup>. It is a divine animated mass, of complexion somewhat like Silver, the union of masculine and feminine spirits.

The quintessence of four, the ternary of two and the tetract of one. These are his generations, physical and metaphysical. The thing in itself is a world without form, neither mere power nor perfect action, but a weak virgin substance, a certain soft, prolific Venus, the very love and seed, the mixture and moisture of heaven and earth. This moisture is the mother of all things in the world; and the masculine, sulphureous fire of the earth is their father.

Now the Rosie Crucians<sup>141</sup>, who without controversy were the wisest of people, when they discourse of the generation of metals tell us it is performed in this manner. The Mercury or mineral liquor, they say, is altogether cold and passive, and it lies in certain earthy, subterraneous caverns. But when the Sun ascends in the East his beams and heat, falling on this hemisphere, stir up and fortify the inward heat of the earth. Thus we see in winter weather that the outward heat of

the Sun excites the inward, natural warmth of our bodies and cherisheth the blood when it is almost cold and frozen. Now then, the central heat of the earth, being stirred and seconded by the circumferential heat of the Sun, works upon the Mercury and sublimes it in a thin vapour to the top of its cell or cavern. But towards night, when the Sun sets in the West, the heat of the earth - because of the absence of that great luminary - grows weak and the cold prevails, so that the vapours of the Mercury, which were formerly sublimed, are now condensed and distil in drops to the bottom of the cavern. But the night being spent, the Sun again comes about to the East and sublimes the moisture as formerly. This sublimation and condensation continue so long till the Mercury takes up the subtle, sulphureous parts of the earth and is incorporated therewith, so that this Sulphur coagulates the Mercury and fixes him at last, that he will not sublime but lies still in a ponderous lump and is concocted to a perfect metal<sup>142</sup>.

Take notice then that our Mercury cannot be coagulated without our Sulphur, for *Draco non moritur sine suo compare*, the Dragon dieth not apart from his fellow. It is water that dissolves and putrefies earth, and earth that thickens and putrefies water. You must therefore take two principles to produce a third agent, according to that dark receipt of Hali the Arabian. *Accipe canem masculum Corascenum et catellam Armeniae: conjunge et parient tibi catulum coloris coeli*. Take, saith he, the Corascene dog and the bitch of Armenia. Put them both together and they will bring thee a sky-coloured whelp. This sky-coloured whelp is that sovereign, admired and famous Mercury, known by the name of the philosopher's Mercury. Now for my part I advise thee to take two living Mercuries; plant them in a purified, mineral Saturn; wash them and feed them with water of salt vegetable<sup>143</sup>; and thou shalt see that speech of the Adepts verified: *Pariet mater florem germinalem, quem ubere suo viscoso nutriet, et se totam ei in cibum vertet, fovente patre*<sup>144</sup>. But the process or receipt is no part of my design, wherefore I will return to the First Matter; and I say it is no kind of water whatsoever. If thou wilt attain to the truth, rely upon my words, for I speak the truth. The mother or First Matter of metals is a certain watery substance, neither very water nor very earth, but a third thing compounded of both and retaining the complexion of neither. To this agrees the learned Valentine in his apposite and genuine description of our sperm. *Materia prima*, saith he, *set aquosa substantia, sicca repeta et nulli materiae comparabilis*. The First Matter is a waterish substance found dry, or of such a complexion that wets not the hand, and nothing like to any other matter whatsoever. Another excellent and well-experienced philosopher defines it thus. *Est terrena aqua et aquosa terra, in terrae ventre terra commixta, cum qua se commiscet spiritus et coelestis comparabilis*. It is, saith he, an earthy water and a watery earth, mingled with earth in the belly of the earth; and the spirit and influences of heaven commix themselves therewith. Indeed it cannot be denied but some authors have named this substance by the names of all ordinary waters, not to deceive the simple but to hide it from the ranting, ill disposed crew. On the contrary, some have expressly and faithfully informed us it is no common water, and especially the reverend *Turba*. Ignari, said Agadmon<sup>145</sup>, *cum audiunt nomen aquae putant*

*aquam nubis esse, quod si libros nostros intelligerent, scirent esse aquam permanentem, quae absque suo compari cum quo facta est unum permanens esse non possit.* The ignorant, saith he, when they hear us name water, think it is water of the clouds; but if they understood our books they should know it to be a permanent or fixed water which, without its companion, to which it hath been united, cannot be permanent. The noble and knowing Sendivogius tells us the very same thing. *Aqua nostra est aqua coelestis, non madefaciens manus, non vulgi, sed pluvialis.* Our water is a heavenly water, which wets not the hands, not that of common water, but almost, as it were, pluvial. We must therefore consider the several analogies and similitudes of things, or we shall never be able to understand the philosophers.

This water then wets not the hands, which is notion enough to persuade us it can be no common water.

It is a metalline, bitter, saltish liquor. It hath a true mineral complexion. *Habet*, saith Raimund Lullus, *speciem solis et lunae, et in tali aqua nobis apparuit, non in aqua fontis aut pluviae*<sup>146</sup>. But in another place he describes it more fully. *Est aqua sicca*, saith he, *non aqua nubis aut phlegmatica, sed aqua choleric, igne calidior.* It is a dry water, not water of the clouds or phlegmatic water, but a choleric water, more hot than fire. It is, moreover, greenish<sup>147</sup> to the sight, and the same Lully tells you so. *Habet colorem lacertae viridis.* It looks, saith he, like a green lizard. But the most prevalent colour in it is a certain inexpressible azure, like the body of heaven in a clear day. It looks in truth like the belly of a snake, especially near the neck, where the scales have a deep blue tincture; and this is why the philosophers call it their serpent or dragon. The predominant element in it is a certain fiery, subtle earth, and from this prevalent part the best philosophers have denominated the whole compound. Paracelsus names it openly but in one place, and he calls it *viscum terrae*<sup>148</sup>, the slime or viscous part of the earth. Raymund Lully describeth the crisis or constitution of it in these words: *Substantia lapidis, nostri, saith he, est tota pinguis, et igne impregnata.* The substance of our Stone is altogether fat or viscous and impregnated with fire - in which respect he calls it elsewhere not water but earth. *Capias terram nostram*, saith he, *impregnatam a sole, quia lapidem est honoratus, repertus in hospitibus, et est intus inclusum velut magnum secretum et thesaurus incantatus.* Take our earth which is impregnated or with child by the sun; for it is our precious Stone which is found in desolate houses, and there is shut up in it a great secret and treasure enchanted. And again, in a certain place, he delivers himself thus: *Prima materia, Fili, est terra subtilis sulphurea, et haec nobilis terra dictum est subjectum mercuriale.* My son, he saith, the First Matter is a subtle, sulphureous earth, and this noble earth is called a mercurial subject. Know then for certain that this slimy, moist sperm or earth must be dissolved into water, and this is the Water of the Philosophers, not any common water whatsoever. This is the grand secret of the Art, and Lully discovers it with a great deal of honesty and charity. *Argentum vivum nostrum*, saith he, *non est argentum vivum vulgare: imo argentum vivum nostrum est aqua alterius naturae, quae reperiri non potest*

*supra terram, cum in actionem venire non possit per naturam, absque adjutorio ingenii et humanorum manuum operationibus.* Our Mercury is not common Mercury or Quicksilver. But our Mercury is a water which cannot be found on earth, for it is not made or manifested by the ordinary course of nature, but by the art and manual operations of man. Seek not then for that in nature which is an effect beyond her ordinary process; you must help her, that she may exceed beyond her common course, or all is to no purpose. In a word, you must make this water before you can find it. In the interim you must permit the philosophers to call their subject or chaos a water, for there is no proper name for it, unless we call it a sperm, which is a watery substance but certainly no water. Let it suffice that you are not cheated, for they tell you what it is and what it is not, which is all that man can do. If I ask you by what name you call the sperm of a chick you will tell me it is the white of an egg, and truly so is the shell as well as the sperm that is within it. But if you call it earth or water you know well enough it is neither; and yet you cannot find a third name. Judge then as you should be judged, for this is the very case of the philosophers. Certainly you must be very unreasonable if you expect that language from men which God hath not given them.

Now that we may confirm this our theory and discourse of the sperm not only by experience but by reason, it is necessary that we consider the qualities and temperament of the sperm. It is then a slimy, slippery, diffusive moisture. But if we consider any perfect products, they are firm, compacted, figured bodies; and hence it follows they must be made of something that is not firm, not compacted, not figured, but a weak, quivering, altering substance. Questionless thus it must be, unless we make the sperm to be of the same complexion with the body; and then it must follow that generation is no alteration. Again, it is evident to all the world that nothing is so passive as moisture. The least heat turns water to a vapour and the least cold turns that vapour to water. Now let us consider what degree of heat it is that acts in all generations, for by the agent we may guess at the nature of the patient. We know the sun is so remote from us that the heat of it, as daily experience tells us, is very faint and remiss. I desire then to know what subject there is in all nature that can be altered with such a weak heat but moisture. Certainly none at all; for all hard bodies, as salts, stones and metals, preserve and retain their complexions in the most violent, excessive fires. How then can we expect that they should be altered by a gentle and almost insensible warmth? It is plain then, and that by infallible inference from the proportion and power of the agent, that moisture must needs be the patient. For that degree of heat which nature makes use of in her generations is so remiss and weak it is impossible for it to alter anything but what is moist and waterish. This truth appears in the animal family, where we know well enough that sperms are moist. Indeed in vegetables the seeds are dry, but then nature generates nothing out of them till they are first macerated or moistened with water. And here the Peripatetic philosophers are quite gone with their *pura potentia*<sup>149</sup>, that fanatic chaos of the son of Nichomachus.

But I must advise my chemists to beware of any common moisture, for that will never be altered otherwise than to a vapour. See, therefore, that thy moisture be well tempered with earth; otherwise thou hast nothing to dissolve and nothing to coagulate. Remember the practise and magic of the Almighty God in His creation, as it is manifested to thee by Moses. *In principio*, saith he, *creavit Deus coelum et terram*<sup>150</sup>. But the original, if it be truly and rationally rendered, speaks thus: *In principio Deus miscuit rarum et densum*. In the beginning God mingled or tempered together the thin and the thick. For heaven and earth in this text signify the Virgin Mercury and the Virgin Sulphur. This I will prove out of the text itself, and that by the vulgar, received translation, which runs thus: In the beginning God created the heaven and the earth. And the earth was without form and void; and darkness was upon the face of the abyss. And the Spirit of God moved upon the face of the waters. In the first part of this text Moses mentions two created principles<sup>151</sup>, not a perfect world, as we shall prove hereafter, and this he doth in these general terms, heaven and earth. In the latter part of it he describes each of these principles in more particular terms and he begins with the earth. And the earth, saith he, was without form and void. Hence I infer that the earth he speaks of was a mere rudiment or principle of this earth which I now see<sup>152</sup>; for this present earth is neither void nor without form. I conclude then that the Mosaical earth was the Virgin Sulphur, which is an earth without form, for it hath no determined figure. It is a laxative, unstable, incompounded substance, of a porous, empty, *crasis*, like sponge or soot. In a word, I have seen it, but it impossible to describe it. After this he proceeds to the description of his heaven or second principle in these subsequent words. And the Spirit of God moved upon the face of the waters. Here he calls an abyss and waters what he previously called heaven. It was indeed the heavenly water or chaos, out of which the separated heaven or habitation of the stars was afterwards made. This is very clear from the original, for *Hamaim* and *Hashamaim* are the same words like *Aqua* and *Ibi Aqua*, and they signify one and the same substance, namely water<sup>153</sup>. The text then being rendered according to the primitive natural truth and the undoubted sense of the author speaks thus: In the beginning - or, according to the Jerusalem Targum, *in wisdom*<sup>154</sup> - God made the water and the earth. And the earth was without form and void; and there was darkness upon the face of the deep. And the Spirit of God moved upon the face of the waters. Here you should observe that God created two principles, earth and water, and of these two He compounded a third, namely the sperm or chaos. Upon the water, or moist part of this sperm, the Spirit of God did move; and, saith the Scripture, there was darkness upon the face of the deep. This is a very great secret; neither is it lawful to publish it expressly and as the nature of the thing requires, but in the magical work it is to be seen, and I have been an eye-witness of it myself.

To conclude: remember that our subject is no common water, but a thick, slimy, fat earth. This earth must be dissolved into water and that water must be coagulated again into earth. This is done by a certain natural agent which the philosophers call their Secret Fire. For if you work with common fire it will dry your sperm and bring it to an unprofitable red dust, of the colour of wild poppy.

Their Fire then is the Key of the Art<sup>155</sup>, for it is a natural agent but acts not naturally without the sun. I must confess it is a knotty mystery, but we shall make it plain if you be not very dim and dull. It requires indeed a quick, clear apprehension. Behold<sup>156</sup> our 7 Bramaah<sup>157</sup> and their wonderful mysteries, for by them you may cure all diseases, young or old, but know first our fire and use in the work.

Fire, notwithstanding the diversities of it in this sub-lunary kitchen of the elements, is but one thing from one root. The effects of it are various, according to the distance and nature of the subject wherein it resides, for that makes it vital or violent. It sleeps in most things, as in flints, where it is silent and invisible. It is a kind of *perdue*, lies close like a spider in the cabinet of his web, to surprise all that comes within his lines. He never appears without his prey in his foot. Where he finds aught that's combustible there he discovers himself; for if we speak properly, he is not generated, but manifested. Some men are of opinion that he breeds nothing but devours all things and is therefore called *Ignis quasi ingignens*<sup>158</sup>. This is a grammatical whim, for there is nothing in the world generated without fire. What a fine philosopher then was Aristotle, who tells us this agent breeds nothing but his *pyrausta*, a certain fly which he found in his candle but could never be seen afterwards. Indeed too much heat burns and destroys; and if we ascend to other natures, too much water drowns, too much earth buries and chokes the seed, that it cannot come up. And verily at this rate there is nothing in the world that generates. What an owl was he then that could not distinguish, with all his logic, between excess and measure, between violent and vital degrees of heat, but concluded the fire did breed nothing because it consumed something. But let the mule pass, for so Plato called him, and let us prosecute our Secret Fire. This Fire is at the root and about the root - I mean about the centre - of all things, both visible and invisible. It is in water, earth and air; it is in minerals, herbs and beasts; it is in men, stars and angels. But originally it is in God Himself; for He is the Fountain of heat and fire, and from Him it is derived to the rest of the creatures in a certain stream or sunshine.

Now the Rosie Crucians<sup>159</sup> afford us but two notions whereby we may know their fire. It is, as they describe it, moist and invisible. Hence they have called it their *venter equi*<sup>160</sup> and *fimus equinus*<sup>161</sup>, but this is only by way of analogy, for there is in horse-dung a moist heat but no fire that is visible. Now let us compare the common Vulcan with this philosophical Vesta, that we may see wherein they are different. First, then, the philosopher's fire is moist, and truly so is that of the kitchen too. We see that flames contract and extend themselves; now they are short, now they are long, which cannot be without moisture to maintain the flux and continuity of their parts. I know Aristotle makes the fire to be simply dry, perhaps because the effects of it are so. He did not indeed consider that in all complexions there are other qualities besides the predominant one. Surely then this dry stuff is that element of his wherein he found his *pyrausta*. But if our natural fire were simply dry the flames of it could not flow and diffuse themselves as they do: they would rather fall to dust or turn, like their fuel, to ashes. The

common fire is excessively hot, but moist in a far inferior degree, and therefore destructive, for it preys on the moisture of other things. On the contrary, the warmth and moisture of the magical agent are equal; the one tempers and satisfies the other. It is a humid, tepid fire, or, as we commonly express ourselves, blood-warm. This is their first and greatest difference in relation to our desired effect: we will now consider the second. The kitchen fire, as we all know, is visible, but the philosopher's fire is invisible, and therefore no kitchen fire. This Almadir expressly tells us in these words: *Solas radios invisibilis ignis nostri sufficere*. Our work, saith he, can be performed by nothing but the invisible beams of our fire. And again: *Ignis moster corrosivus est ignis, qui supra nostrum vas nubem obducit, in qua nube radii hujus ignis occulti sunt*. Our fire is a corrosive fire which brings a cloud about our glass or vessel, in which cloud the beams of our fire are hidden. To be short: the philosophers call this agent their bath, because it is moist as baths are; but in very truth it is no kind of bath, neither *maris* nor *roris*<sup>162</sup>, but a most subtle fire, and purely natural; but the excitation of it is artificial. This excitation or preparation is a very trivial, slight, ridiculous thing. Nevertheless all the secrets of corruption and generation are therein contained. Lastly, I think it just to inform thee that many authors have falsely described this fire, and that of purpose, to seduce their readers. For my own part I have neither added nor diminished. Thou hast here the true, entire secret, in which all the easterns agree, Alfid, Almadir, Belen, Gierberim, Hali, Salmanazar and Zadich, with the three famous Jews, Abraham, Arthephus and Kalid. Now I will tell thee how to use it.

Take our two serpents, which are to be found everywhere on the face of the earth. They are a living male and a living female<sup>163</sup>. Tie them both in a love-knot and shut them up in an Arabian *Caraha*<sup>164</sup>. This is thy first labour, but thy next is more difficult. Thou must encamp against them with the fire of nature, and be sure that thou dost bring thy line about. Circle them in and stop all avenues, that they find no relief. Continue this siege patiently; and they will turn into an ugly black toad, which will be transformed to a horrible devouring Dragon, creeping and weltering in the bottom of her cave, without wings. Touch her not by any means, not so much as with thy hands, for there is not upon this earth such a violent transcendent poison. As thou hast begun so proceed, and this Dragon will turn to a Swan, but more white than the hovering, virgin snow when it is not yet sullied with the earth. Henceforth I will allow thee to fortify thy fire till the Phoenix appears. It is a red bird of a most deep colour, with a shining, fiery hue. Feed this bird with the fire of his father and the ether of his mother<sup>165</sup>; for the first is meat and the second is drink, and without this last he attains not to his full glory. Be sure to understand this secret, for fire feeds not well unless it first be fed. It is of itself dry and choleric; but a proper moisture tempers it, gives it a heavenly complexion and brings it to the desired exaltation. Feed thy bird then as I have told thee, and he will move in his nest and rise like a star of the firmament. Do this and thou hast placed nature in *horizonte aeternitatis*<sup>166</sup>. Thou hast performed the command of the Kabalist: *Fige finem in principio, sicut, flammam prunae conjunctam, quia Dominus superlative unus et non tenet secundum*. Unite the

end to the beginning, like a flame to a coal; for God, saith he, is superlatively one and He hath no second<sup>167</sup>. Consider then what you seek; you seek an indissoluble, miraculous, transmuting, uniting union; but such a tie cannot be without the First Unity. *Creare enim*, saith one, *atque intrinsecus transmutare absque violentia, munus est proprium duntaxat Primae Potentiae, Primae Sapientiae, Primi Amoris*. To create and transmute essentially and naturally, or without any violence, is the only proper office of the first Power, the first Wisdom and the first Love. Without this love the elements will never be married; they will never inwardly and essentially unite, which is the end and perfection of magic. Study then to understand this, and when thou hast performed I will allow thee that test of the *Mekkubalim: Intellexisti in sapientiam et sapuisti in intelligentia; statuisti rem super puritates suas, et Creatorem in Throno Suo collocasti*<sup>168</sup>.

To close this section, I say it is impossible to generate in the patient without a vital, generating agent. This agent is the philosophical fire, a certain moist, heavenly, invisible heat. But let us hear Raymund Lully describe it: *Quando dicimus*, saith he, *quod lapis per ignem generatur, non vident alium ignem, nec alium credunt, nisi ignem communem; nec aliud Sulphur, nec aliud Argentum Vivum, nisi sit vulgare. Ideo manent decepti per eorum caecas estimationes, inferentes quod causa sumus suae deceptionis et quod dedimus illis intelligere rem unam pro alia. Sed non est verum salva eorum pace, sicut probabimus per illa quae philosophi posuerunt in scriptis. Solem enim appellamus ignem, et vicarium suum vocamus calorem naturalem. Nam illud quod agit calor solis in mineris metallorum per mille annos, ipse calor naturalis facit in una hora supra terram. Nos vero et multi alii vocamus eum Filium Solis, nam primo per solis influentiam fuit generatus per naturam, sive adiutorium scientiae vel artis*. When we say the Stone is generated by fire, men neither see, neither do they believe there is any other fire but the common fire, nor any other Sulphur and Mercury but the common Sulphur and Mercury. Thus they are deceived by their own opinions, saying that we are the cause of their error, having made them to mistake one thing for another. But, by their leave, it is not so, as we shall prove by the doctrine of the philosophers. For we call the sun a fire and the natural heat we call his substitute or deputy. For that which the heat of the sun performs in a thousand years in the mines, the heat of nature performs above the earth in one hour. But we and many other philosophers have called this heat the Child of the Sun, for at first it was generated naturally by the influence of the sun without the help of our Art or knowledge. Thus Lully: but one thing I must tell thee, and be sure, Reader, thou dost remember it. This very natural heat must be applied in the just degree and not too much fortified; for the sun itself doth not generate but burn and scorch where it is too hot. *Si cum igne magno operatus fueris*, saith the same Lully, *proprietas nostri spiritus, quae inter vitam et mortem participet, separabit se et anima recedet in regionem sphaerae suae*. If thou shalt work with too strong a fire, the propriety of our spirit, which is different as yet to life or death, will separate itself from the body, and the soul will depart to the region of her own sphere.

Take therefore along with thee this short but wholesome advice of the same author: *Facis ergo, Fili, quod if loco generationis aut conversionis sit talis potentia coelestis quae possit transformae humidum ex natura terrestri, in formam et speciem transparentem et finissimam*. My son, saith he, let the heavenly power or agent be such in a place of generation or mutation that it may alter the spermatick humidity from its earthly complexion to a moist fire, transparent form or species.

See here now the solution of the slimy, fat earth to a transparent, glorious Mercury! This Mercury is the water which we look after, but not any common water whatsoever. There is nothing now behind but that which the philosophers call *Secretum Artis*<sup>169</sup>, a thing that was never published and without which you will never perform, though you know both fire and matter. An instance hereof we have in Flamel, who knew the Matter well enough and had both fire and furnace painted to him by Abraham the Jew; but notwithstanding he erred for three years because he knew not the secret. Henry Madathan, a most noble philosopher, practised upon the subject for five years together but knew not the right method and therefore found nothing. At last, saith he, *Post sextum annum clavis potentiae per arcanam revelationem ab omnipotente Deo mihi concredita est*; after the sixth year I was entrusted with the Key of Power by secret revelation from the Almighty God. This Key of Power or third secret was never put to paper by any philosopher whatsoever. Paracelsus indeed hath touched upon it, but so obscurely it is no more to the purpose than if he had said nothing.

And now I have done enough for discovery and regimen of the fire, and more than any one author hath performed. Search it then, for he that finds this fire will attain to the true temperament; he will make a noble, deserving philosopher and, to speak in the phrase of our Spaniard, *Dignus erit poni ad mensam duodecim parium*<sup>170</sup>.

And now I will teach you how to make the DRAMAAH into Medicine mixed with the metals. And first

### **Of Mercury**

The Rosie Crucians describe unto us the Mount of God and his Mystical, philosophical Geomancy, which is nothing else but the highest and purest part of the earth; for from Tetragrammaton He shines upon the Orders and they carry His power to the planets, so you see the superior, secret portion of this element is holy ground; it is the seed plot of the eternal nature. And the Chaos was divided into eight parts; the eight<sup>171</sup> was deadly, but first of the seven; the matter was the body of the lapsed Angels<sup>172</sup>. After light began to appear<sup>173</sup>, the centre<sup>174</sup> was red, an ash colour blush; the circumference blue. The second division green, fiery red and purple. In the third division the centre was fiery, the inferior waters purple and the superior white. The fourth division was azure blush, the Sun and Moon then appearing pale blush. In the fifth division the earth was red and the centre fiery, the waters blush azure, the Sun and Moon ash colour. The sixth

division of the earth was a red blush, and centre fiery. The seventh apparition is the immediate vessel and recipient of heaven, whence all minerals have their life and by which the animal monarchy is maintained.

This philosophical black Saturn mortifies and coagulates the invisible Mercury of the Stars and, on the contrary, the Mercury kills and dissolves the Saturn; and out of the corruption of both, the Central and Circumferential Suns disgenerate new bodies, the Green Lion in a blush circle; the Green Lion swallowed to the hinderparts; the virtues in a purple vessel of Nature, half Moon made; the vegetable animal mineral in a blush; calcination of fiery and blue earth; sublimation fiery, airy and azure; solution black, white and azure; the Spirit descends. The masculine and feminine Mercury generated there will appear azure, purple, ash colour, yellow and red. In putrefaction our matter is black and azure; the Spirit descends. In conception our *Astrum Solis* is a bloody, fiery, spirited earth; the Spirit descends and the superfinals [are] azure. In impregnation the *Astrum Solis* ascends from a muddy water and the Spirit with it. In fermentation the black, shabby toad lies sultering in his vessel, and the Spirit in azure descending appears in separation of fire, air, water and earth. The toad lies in the earth black, the earth ash colour, the water green, the air blue, the fire blood-red and the aether a liquid white fire; the Spirit ascends. In conjunction of elements the fire is red, air blue, water green and earth dark ash and the Spirit descends in a clear sky. In separation of earth, fire, air and water, the earth lies in the bottom dark, the fire flaming upon it, breaking through the air to the water, and disposeth itself in conjunction of water in air; the Spirit descends in a clear sky to that blue composition; the air in the water is green, the fire red and the earth ashy. In the separation of fire, water, air in water, earth, the earth is dark, muddy, the air in water blue, the water transparent and the fire flaming red and white, and the Spirit ascends in an azure sky.

In conjunction of air in fire, fire in water, water in air, earth, the earth is dark and heavy, the water in air blue, the fire in water green, the air in fire a blush red; the Spirit descends in a clear sky. In separation air, water, fire in air, earth, the earth is ash colour, fire in air blood red, flaming through the azure water and air; the Spirit ascends. In conjunction fire in air, water in fire, air in water, earth, the earth is black, the air in water is green, the water in fire is like the sunbeams in a mist, the fire above all lies in the air blue, flaming; the Spirit descends. The next separation is flames of fire breaking out in all the elements, the earth only lies of a darker colour. The unnatural fire stands thus, air water, fire earth, the earth covered with a blue flame, the fire ascending to the central colour, water and air; the Spirit descends. The rising of the Rosie Crucians Medicines. The earth *cineri coloris*, a white star and moon appearing in a star; the power and Spirit ascends in a clear sky. In fermentation a dark star lies in the earth and the Spirit descends to it in a clear sky. In purgation the earth is black and the Spirit descends clear. In this separation there appears water in air, fire in water, turned upwards; below is a blue space, then the earth in fire is red, air in earth ash colour.

[In] this conjunction of air in fire, water in earth, fire in air, earth in water; the earth in water is dark, the fire in air red, but not violent, the water in earth green, the air in fire blue; the Spirit descends. And [in] this conjunction of earth in air, water in fire, and fire in earth; here in the bottom the earth is animated with a secret fire, invisible, occult, the water shadows a mild fire, the air in water above these is green and glorious, the earth in air is a bluish white; the Spirit descends.

In this exaltation of the Quintessence the Pelican is in the bottom; next above is azure; then two circles; of the first the upper is blue, the lower a white fire; the next is a green and red sea of fire environing the white matter, and this exaltation of the Quintessence is azure, a globe [which] in the bottom [is] divided in four quarters; from the East to the South is blue, from the South to the West green, from the West to the North white, from the North to the East red, and all the upper part of it azure. Above this globe the fire flames upon both sides. In fixation the branches of fire spread both ways round the white and azure globe; this projection is upon a blue and white powder, the perspect in Multiplication runs down the vessel through the azure to the matter in the bottom.

In imbibition the Serpent lies at the bottom of the matter; in sublimation a strong fire drives the azure part to the top; in coagulation the azure binds or weighs down the fire to the bottom; in conjunction the fire star lies in the bottom; in the<sup>175</sup> exaltation the double circled fire arises, and in the<sup>176</sup> quintessence appears an Angel amidst the ascending globes of fire; and in fixation all is circled with purple and red fire and in the middle stands an Angel in a star, doubled, with his wings spread and holding the glorious Crown of the Rosie Cross in his hands.

1. Of the Preparation of the Gold, Mercury or Argent Vive. 2. Purification. 3. Sublimation. 4. Calcination. 5. Exuberation. 6. Solution. 7. Separation. 8. Conjunction. 9. Putrefaction into Sulphur. 10. Fermentation. 11. Multiplication in virtue. 12. Multiplication in quantity.

1. He that can make the medicine of Argent Vive or Mercury alone is the greatest searcher out of Art and Nature because there is all that in Mercury which wise men seek. For Quicksilver is the Mother and Sperm of all metals and their nearest matter, and it is not only a spirit but a body; it is also a middle nature and also a Sulphur; it is a lingering Mercury; it dieth and riseth again and is fixed with its own proper elements; wherefore it is first necessary that it be purged from its impurities.

2. The Purgation or Purification is on this wise. Grind it upon a marble with a mullet, or a wooden pestle in a wooden mortar, with common salt and a little vinegar sprinkled thereupon till the salt be black; then wash it well with vinegar and dry it easily at the fire or at the sun; then strain it through a double cloth or a new skin of a sheep till it be dry and the vinegar clear taken away and be of a white colour and clear.

3. Grind it upon a marble with a little Mercury Sublimate and let it mortify and incorporate with it; then grind it with its equal weight of Saltpeter and green Copperas till it be like a paste; then put all into a subliming glass and in ashes sublime all the mercury that it be white and clean as snow in the head of the limbeck; sublime it again three times or oftener, and it will be pure Mercury and<sup>178</sup> Sublimate.

4. Put a pound of this Mercury Sublimate into two pounds of common *Aqua Fortis* by little and little at once till all be dissolved like sugar in wine; then shut the glass and set it *in Balneo* to dissolve the space of ten days; then distil away the *Aqua Fortis* in a lent heat *in Balneo* and the Mercury will remain in the bottom like butter, of a white colour and calcined by Corrosive Water.

5. Put this calcined Mercury into an earthen body with a limbeck and in ashes sublime the whole dissolved substance three times, which will all be very white, and then it is called Mercury Exuberate.

When you have three or four pound of this, receive<sup>179</sup> the third part and fix it by often sublimation till it remain in a hard mass and ascend no more but remain fixed, which is called the Glue of the Eagle or the prepared body permanent and the volatile made fixed, which is to be reserved for the earth of the Stone.

6. Dissolve the other two parts *in Balneo* or in a cold cellar or put it in a bladder and hang it over fuming hot water till it be all come to water. Take this water thus made and digest it in a Circulatory, well closed, the space of nine days, then put it in a body with a head and receiver well luted and in ashes or [*in*] *Balneo* distil the water of a white colour, or milky white, which is called *Lac Virginis*, dissolving all metals, and so you have separated the Spirit of the Stone, which is also called the lingering Spirit and the white tincture of the white Stone of Mercury.

7. Take the third part which before you reserved and fixed, called the Glue of the Eagle, as much of it as you please, and add thereto equal weight of its Spirit or *Lac Virginis*<sup>180</sup> and stop up the glass and so you have joined the man and the woman, Mercury with her own earth, the Spirit with the body.

8. Set your *Lac Virginis* thus joined with his own, each *in Balneo* to putrefy 150 days and there let it stand unmoved. After 40 days it will be black and it is then called the Head of the Crow; then it will be of a green colour, after that the Peacock's Tail and many false colours, for between this and white it will appear red; but at last you shall see it white and then increase your fire and it will stick to the sides of the glass like fishes eyes<sup>181</sup>, then you have each in the nature of Sulphur.

Take of this Sulphur as much as you please and weigh it and add thereto two parts of the white tincture or *Lac Virginis* and set it *in Balneo* to dissolve the space of six days; then distil away the *Lac Virginis* or tincture, and the Sulphur

will remain in the form of liquor, for it is the liquor of the white Sulphur of Mercury which is to be joined with the liquor of the Sulphur of Luna or Silver.

9. The Sulphur of the white luminary, or Silver, or Luna, is made as the other, whereof we shall speak more in the next branch. This liquor of the Sulphur is the Soul, which is joined with the Spirit and body, which quickeneth the whole Stone. The other conjunction before was only the union of the Spirit and the body, but this is a threefold copulation, viz., the uniting of the Soul, Spirit and Body<sup>182</sup>. Add equal weight of these two liquors of Sulphur, that is to say the liquor of the Sulphur of Mercury and of Silver or Luna and close well the glass and set it in ashes till it be white, for it will be all colours again and at last white; and then it is the perfect Stone converting all metals into Silver.

10. This Medicine or Elixir is thus multiplied in virtue. Dissolve it in *Lac Virginis* and distil it away and dry it and dissolve it again etc. And let it be so often dissolved and dried till it will dry no more but remain an incombustible oil, and is then Elixir of the third order.

11. Take one part of this Elixir and project it upon 100 or 1,000 parts of melted silver (according to the goodness and virtue thereof) and it will turn the Silver into a brittle mass or substance, which beat to a powder in an iron or brass mortar, or upon a marble and project one part of this powder upon 100 parts of Mercury, purged, made hot, and it will be perfect Medicine whereof one part turneth 100 or 1,000 parts of the bodies into good silver. And this way is your Medicine multiplied in quantity. Here followeth the Mercurial Medicine prepared after we have taught you to make the Medicine of the Moon.

12. It remaineth now that we speak of the Medicine of the Elixir of Life, which is called Potable Silver. But although the liquor of Silver may be made potable Silver if it be corroborated<sup>183</sup> before by digestion *in Balneo* seven days with the Spirit of Wine, and then distil away the Spirit of Wine that the oil of the Silver may remain in the bottom, which may easily be given for medicine, yet the philosophers would have us do otherwise; for they teach us to bring the metals first into their Quintessence before they be taken inwardly, and that there are<sup>184</sup> no other Quintessences but those that are of a Second Nature according to the old saying:

*Elixir de te est res secunda  
De quo sunt facta corpora munda.*

That is to say the four Elements are destroyed and by putrefaction a new body [is] created and made into a Stone, which is the Quintessence as Lully would have it. But I do boldly and constantly affirm that there is no true Silver or Potable Silver nor Quintessence unless it be first Elixir, and that is done in a quarter of an hour by projection of the Elixir upon Silver or pure Gold, molten, according as the Elixir was red or white. If, therefore, you desire after the first composition of the Elixir to make the Arcanum of *Argentum* or *Aurum Potabile*, project the Elixir or

Medicine according to his quality or property upon pure Silver or Gold, molten, and then it is made brittle and frangible, and grind it to a powder and take thereof so much as you please and dissolve it in distilled Vinegar (or rather in Spirit of Wine) the space of nine days. Then distil away the Vinegar or Spirit of Wine [and] that which remaineth in the bottom is the true Medicine, Quintessence, Elixir of Life, Ferment of Ferments and Incombustible Oil converting metals and man's body into perfect health from all diseases of man's body which proceed from Mercury or Luna. And thus is the true Potable Silver made, curing the vertigo, syncope, epilepsy, madness, phrensy, leprosy, etc.

And this is the right way of making the Stone of Mercury alone; but the Elixir cannot be made without the addition of Silver to the white and of Gold to the red.

To each this work, consider eight principles:

1. Luna.
2. Pure Silver.
3. Calcination.
4. Solution.
5. Putrefaction.
6. The Sulphur.
7. The Liquor of the Sulphur.
8. White Ferment.

Hermes saith the Elixir is nothing else but Mercury, Sol and Luna. By Mercury nothing is understood but the Sulphur of Nature, which is called the true Mercury of the philosophers, and that Sulphur gotten by putrefaction by the conjunction of the Spirit and the body of imperfect bodies and metals.

By Sol is meant Gold, by Luna, Silver; both of them are to be joined to imperfect bodies, that is to say, white Sulphur and Red, whence the same Hermes, in his seven[th] treatise of Sol, saith there happeneth a conjunction of two bodies, and it is necessary in our maistry. And if one of those bodies only were not in our Medicine, it would never by any means give any tincture. Upon which Morienus saith: For the Ferment prepareth the imperfect body and converteth it to its own nature and there is no Ferment but Sol and Luna, that is Gold and Silver. Of which Rosinus [saith]: Sol and Luna prepared (that is to say their Sulphurs) are the ferments of metals in colour.

But this is made more evident by Raymund in his *Apertory*, where he saith there is no Ferment except Sol and Luna, for the Ferment of the Medicine to white is Silver and to the red Gold, as the philosophers do demonstrate, because without Ferment there doth proceed neither Gold nor Silver nor anything else that is of its kind or nature, therefore join the Ferment with its Sulphur that it may beget its like, because the Ferment draweth the Sulphur to its own colour and nature also, and weight and sound<sup>185</sup>, because every like begetteth its like. Because the Ferment, even as Sol, tingeth and changeth his Sulphur into a permanent and piercing Medicine, therefore the philosopher saith: He that knoweth how to tinge Sulphur and Mercury with Sol and Luna shall attain to the greatest secret. And for this reason it is necessary that Sol and Luna be the tincture and ferment thereof.

2. And so also Arnoldus saith in his *Rosary*, there is no body more noble and pure than Sol or his shadow, that is to say Silver, without which no tingeing Mercury is generated. He that endeavoureth to give colour without this Gold or Silver goeth blindly to work, like an ass to a harp, for Gold giveth a golden and Silver an argentine colour; therefore he that knoweth how to tinge Mercury with Sol and Luna cometh or reacheth to the secret which is called white Sulphur, the best to Silver, which, when it be made red, will be red Sulphur, to Gold best.

3. Take pure Luna, that is to say Silver. That is best which is beaten into leaves; and bring it into calx with Mercury, and it is then called water Silver; then is the Luna well prepared for calcination.

4. When you have your Silver thus prepared, take four or six ounces thereof and put it in double proportions of *Lac Virginis* mixed with equal quantity of corrosive water to dissolve in an egg glass. After it hath dissolved so much as it can in the cold, set [it] *in Balneo* and there let it stand nine days till the whole substance of the silver be dissolved into a green water. Then let the *Balneum*<sup>186</sup> cool and take it out and put the dissolution into the body and set thereon a head and distil off the water from the matter remaining, which is the oil of Silver, calcined not into a calx but [into] a liquor, because this *Lac Virginis*, if it be mixed or joined with common *Aqua Fortis* or alone without it (as it pleaseth the operator) is so strong that the very Diamond cannot resist it but is dissolved. Therefore this water is called the Water of Hell and is the only miracle of miracles of the world, because it containeth such a fiery nature in itself and propriety of burning of all bodies into liquor, whereas the elemental fire prevaieth no further than to reduce metals into calx or ashes. But to return from whence I digressed, I now come to the third operation.

5. To the end, therefore, that this liquor or oil of Silver may be more perfectly dissolved, and that all the imperfection of adustion<sup>187</sup> may be taken away, which by the ancients is called the corroborating of the le[a]st humidity, put the oil or liquor into another egg glass like the former, pour thereupon so much Spirit [of Wine] above it [as shall reach to a depth of] four fingers, then close well the glass and set it *in Balneo* to digest seven or ten days and you shall find the oil or liquor turned into a thin or rare water [or] oil. Put this water into a still and *in Balneo* draw away the spirit of wine till none of the Spirit of Wine remain with the Silver dissolved, and thus you have your Silver prepared for putrefaction.

Observe the power of the Moon and her Angel [upon] Hasmodai<sup>188</sup>, Muriel, Populus, Via and Silver. Practice and prepare after this manner. This Medicine cures all the diseases of the neck and breast etc. It must be Silver purely refined.

Geomancy the Harmony in this Preparation<sup>189</sup>.

(geomantic pic missing)

6. This liquor of Silver is potable, but not the Quintessence. Put this water into a fit putrefying glass and seal it up and set it to putrefy *in Balneo* till the time of putrefaction be past, which is about one hundred and fifty days, and when you see the first sign of putrefaction, which is called the head of the Crow, increase your fire a little till all the colours begin to appear and you see it begin to be white.

When you see it white, increase your fire yet more and it will rise up and stick to the sides of the glass, most transparent, like the eyes of fishes<sup>190</sup>, which is Sulphur of Nature or Salt, or the putrefied body of the white luminary, viz., Luna, which yet is not so hard as a body nor so soft as a Spirit, but of a mean hardness between a Spirit and a body, and is called the Philosophers' Mercury and the Key and means of joining Tinctures.

7. But to come to the liquor of the white Luminary. This body being brought into Quintessence is prepared for dissolution like the Sulphur of the imperfect body; but whereas that is done by virtue of the white tincture or *Lac Virginis*, I rather do it by virtue of the fire natural, which is the Spirit of Wine; and after the drawing away thereof it remaineth in a liquor.

Now this liquor of Luna dissolved is the Quintessence, which then is the liquor of the white luminary and the soul<sup>191</sup> (as Eximandrus saith) quickening the whole Medicine, without which it is dead and will never give form nor colour.

8. Therefore the fourth part of the liquor of the white luminary is to be joined to three parts of the former liquor of the Sulphur of Mercury, and after to be kept in a lent fire of ashes, well closed, till it pass through all colours and at last come to its former colour of whiteness; and so the Medicine is fermented<sup>192</sup> and turned into the white Elixir.

The residue of the foresaid dissolved Sulphur keep diligently, and therewith ferment the white Sulphur of other imperfect bodies or stones into Elixirs, which, when they are thrice dissolved and again congealed and remain in a liquid, then they are called incombustible oils and Elixirs of the third order<sup>193</sup>.

And thus the Medicine is made of Mercury alone as followeth by this example. Having spoken of the white Medicine it now resteth that we speak of the making of the Red Elixir, whereof there are two processes, the first whereof is from the Radix, i.e., the long way; the other an accurtation that is much shorter and more excellent. And this way the Elixir may be made in eighty days, and excels all other accurtations; neither is there found therein any diminution of the virtue, but a plentiful and perfect fullness of power and virtue, having all the properties which the Elixir ought to have.

### **The Operation Under Those Heads**

1. Vivum<sup>194</sup>. 2. Sublimation. 3. Calcination. 4. Precipitation. 5. Solution. 6. Fixed Oil. 7. Incertation<sup>195</sup>. 8. Dessication. 9. Contrition. 10. Fermentation. 11. The Red Elixir. 12. The Third Table.

1. Purgation of Mercury I shall omit because it was spoken of before.

2. The Sublimation is to be done otherwise than in the former work, for that which is called Sublimation here is not done with Vitriol and Saltpeter, but is only the distillation of the Mercury in an earthen body with a limbeck, and that without any additament.

3. When the Mercury is once sublimed in ashes wholly into the head of the limbeck, having a retainer joined thereto, take off the head and with a feather gather the sublimed matter and you shall find your Mercury of a black colour, having lost its fairness, and like a dust or powder sticking to his body.

4. Put it again into the body and sublime it as before, and reiterate this work seven or nine times until you have a sufficient quantity of this powder, a pound or more and this is the Calcination.

5. When you see your Mercury will ascend no more, but remain[s] in the bottom of a black colour, and that it is dead and brought perfectly into calx, let it cool and remove your body into sand till it be turned into a red colour. And this is the perfect Precipitation, [to] prove<sup>196</sup> [which], without the help of any corrosive water, take a little of this powder upon a hot Iron plate. If it fume, dry it longer, if not it is well.

6. Take of this red powder as much as you will dissolve and put thereupon at least his double weight of *Lac Virginis* and set *in Balneo* till you see your *Lac Virginis* stained a yellow or red colour; then filter it from its feces and keep it by itself in a glass well stopped and dry the matter that remaineth in ashes and pour thereon new *Lac Virginis* and do as before, till you have drawn out all the tincture and your Mercury is dissolved.

7. Put these solutions into a body, luting to a head and *in Balneo* distil away the *Lac Virginis* and the red oil precipitate will remain, which is fixed and needeth no distillation, but is the tingeing oil of red Mercury, and the red tincture of the red Medicine of Mercury, and the Soul and Spirit of the Medicine joined as for example.

8. Take part of the white Sulphur reserved in the first Table, and rubify it in ashes till it be red. Then imbibe it with equal weight of the oil of the tincture of this red Mercury and set it to dissolve *in Balneo*; and when you see it is dissolved into a liquid substance, take it out.

9. Then set it in ashes, or under the fire, to fix till the matter, being dried, remain fusible and fixed, standing in a mean heat, not over-hot, which try upon a hot iron plate; and if it fume not it is well; if it do, increase your fire till it be totally fixed and dry.

10. If this matter be imbibed again with its oil till it drink up as much as it will, and again dissolved *in Balneo* and then dried in ashes, it will show many colours and lastly appear red<sup>197</sup>. And then it is the Stone, penetrating and fusible, apt for form.

11. Join this imbibed matter (or Medicine) with the fourth part of the liquor or oil of the red Sulphur of Gold or the red Ferment, and dissolve it *in Balneo* and dry it again; and again dissolve it in a glass hanged in the fume of hot water or *Balneum* and congest it again till it stand like honey. Then it is the perfect Red Elixir of Mercury.

12. The Multiplication or Augmentation of the virtue and quantity is showed in the preparation before of the White Elixir.

### **Of Gold - Sol**

1. The Preparation of Gold, Sol. 2. Purged Gold. 3. Calcination. 4. Solution. 5. Putrefaction. 6. *Filius Solis Coelestis*. 7. *Filia Lunae Coelestis*.

1. The Putrefaction or Purgation of Gold is done as the Goldsmiths use to do by melting it with Antimony, that the Gold may remain in the bottom pure and clear from the metals, which they call *Regulus*.

2. Take 4 or 5 ounces of this refined Gold leaf or filings and dissolve it in *Lac Virginis* mixed with equal weight of *Aqua Fortis*, wherein Salt Armoniack sublimed is dissolved, and when it is dissolved into a red liquor, or deep yellow, then it is well calcined.

3. The Solution and Putrefaction is done as before you did with Silver in the preparation of the White Ferment.

4. When you have your white Sulphur of Nature (after Putrefaction) sticking to the sides of the glass<sup>198</sup>, let it cool and take out of the glass and set it in ashes and increase your fire, but not too much, lest your matter vitrify, and let your ashes be no hotter than you can hold your hand therein, and so let it stand till the Sulphur be of a perfect deep red colour. Then have you the red Sulphur of the red luminary as for example -

Observe the Harmony of Geomancy in this Preparation

Behold the power of the Sun and his Angel upon Sorath, Verchiel, Fortuna Major and Minor in Gold and of his Medicine, which, being thus prepared, hath performed incredible, extraordinary cures upon the bodies of Princes and Peers in Europe.

5. If you resolve this red Sulphur in Spirit of Wine or distilled Vinegar into an oil, it is then the liquor of the red luminary and *Aurum Potabile* curing all infirmities if the Spirit of Wine or Vinegar be distilled from it; but for this work it were better to dissolve it in our red *Lac Virginis*, distil away the *Lac* from the Sulphur in ashes, and the Sulphur remaining in an oil is the Ferment of all stones to the red.

6. The Augmentation of this red Elixir in virtue is with his red Tincture as before in the white Tincture. The Augmentation in quantity is by projection upon the body of Gold molten, and that brittle matter of Gold upon Mercury; and if it be powdered, and resolved with Spirit of Wine in an oil, as was said before of Silver, then it is the Quintessence of Gold and the Great Elixir of Life, and the Spiritual Ferment for the transmutation of metals and for the health of man's body.

Although Raymund, writing to the King, was pleased to say that every accurtation diminisheth the perfection, because Medicines which are made by accurtation have less effect of transmutation - which I also assent to with him for a great truth, if the work be begun from the first fountain - yet because this work has its beginnings from those things, which before were brought to a perfect degree of perfection, therefore in this there is no diminution of the perfection<sup>199</sup>.

Therefore it ought to be declared unto thee that if they be both well prepared (and that thou begin with them) thou wilt do a wonderful work without any great labour sooner than if thou should begin with one thing alone. Therefore, my son, begin thy work of two things together as I showed thee in the greater Medicines, when we spoke of the two-fold custody of the actions which are caused by the bodies and spirits. Thus far Raymund. By that which is caused by the bodies and Spirits he means nothing else but Sulphur, willing that we should begin with Sulphur, to which I do so well agree that I begin this my accurtation with this Sulphur alone, and I add no other body to this Elixir, but only the Sulphur of Mercury, alone created of his own body and Spirit.

Take, therefore, two ounces of the white Sulphur described at the beginning of this treatise, and set it in ashes to rubify. In thirty days it will be turned into red Sulphur which when you have done, dissolve that Sulphur in the red Tincture of

Mercury; when it is dissolved draw away the Tincture; in the bottom remaineth the Liquor of Sulphur.

To which, if you add a due proportion of the liquor of the red luminary, it will be perfect Ferment, which, if you dissolve and congeal as before is showed, it is then Elixir of very great virtue to the red work, and no man can make a shorter abbreviation in the world; and when the Sulphur of any body is prepared, it may this way very speedily be converted into Elixir by adding the liquor of the Ferment.

Now I will lay down instructions concerning:

1. The Body. 2. The Spirit. 3. The Lion. 4. The Eagle. 5. The Philosophers' Lead. 6. Antimony. 7. Antimony Mercury. 8. The Glue of the Eagle. 9. Solution of the red Lion into Blood. 10. Solution of the Glue of the Eagle. 11. Solution of the Blood of the red Lion. 12. Conjunction. 13. Putrefaction. 14. Fermentation. 15. In the Trinity of the Physical and Alchemical Tincture of the Soul. 16. Is the Unity of the Medicine.

1. Take Antimony, calcined, so much as you please and grind it to a subtile powder; then take twice so much *Lac Virginis* and put your powder of Antimony therein and set it *in Balneo* seven days; then put it into a body and set it in sand or ashes till the *Lac* be turned red, which draw off and pour on more, and so let it stand. When that is coloured red, pour it to the other and thus do till you have drawn out all the Tincture. Set all this water *in Balneo* or lent ashes to distil with a limbeck, and distil it with a lent fire; and first of all the *Lac* will ascend, [and] then you shall see a stupendous miracle because you shall see through the nose of the Limbeck as it were a thousand veins of the liquor of this blessed Mineral to descend in red drops, just like blood, which, when you have got, thou hast a thing whereunto all the treasure in the world is not equal. Now you have the Blood of the Lion according to Rupecissa. I will now speak of the Glue of the Eagle, of which Paracelsus thus saith.

2. Reduce Mercury so far by sublimation till it be a fixed crystal. This is his preparation of Mercury and by his way of reducing it into the Glue of the Eagle; but above all I require that that way be used which is described by me before or that hereafter set down after this.

3. Then, saith the aforesaid author, go on to resolution and coagulation, and I again will give you to observe the same manner of solution showed at first.

4. Now let us come to conjunction. After the solution of these two, take equal weight of them and put them in a vessel well shot<sup>200</sup>.

5. After you have thus joined them together, set your glass in your furnace to putrefy and after the space of certain days<sup>201</sup>. Therefore Paracelsus saith: Then at length and presently after your Lily<sup>202</sup> is made hot in your glass, it appeareth in

wonderful manners (or demonstration) blacker than the Crow. After that, in process of time, whiter than the Swan, and then passing by yellow to be more red than blood.

6. This being putrefied and turned into red, is to be taken for the Medicine, and then it is time to be fermented.

7. Of which fermentation<sup>203</sup> Paracelsus thus speaketh: one part thereof is to be projected upon 1,000 parts of molten Gold and then the Medicine is prepared, and this is the fermentation of it. But if the half or one part of the liquor of the Sulphur of Gold before described be added to it, then it would be spiritual Ferment and would be much more penetrating in fortitude and fusible, as Paracelsus doth testify in his *Aurora*, where he would have us to join the Star of the Sun or the oil of Sol to this Pantarva<sup>204</sup>. And thus the physical, alchemical Tincture is performed in a short time, for curing all manner of infirmities and human diseases (which is also the Great Elixir for metals so courtly concealed by the ancients) which Hermes Trismegistus the Aegyptian, Osces the Graecian, Haly an Arabian and Albertus Magnus a German, with many others have sought and prosecuted, everyone after his own method, and one in one subject another in another, so much desired by the philosophers only for prolongation of life.

8. In this composition Mercury is made a fixed and dissolved body, the Blood or Spirit of the Red Lion is the Ferment or Soul, and so of trinity is made unity, which is called the physical and alchemical tincture, never before that I know of collected or writ in one work, and I had not done this except that otherwise the composition of this blessed Medicine had been soon forgot.

#### **A Shorter Way To Make The Glue Of The Eagle**

If you desire to make the Glue of the Eagle in a briefer way, take part of the red precipitate produced<sup>205</sup> as it is taught before in Mercury, and dissolve it in distilled Vinegar and the Vinegar will be coloured into a yellow or delightful golden colour; and after you have distilled away the Vinegar, there will remain in the bottom a white substance of the Mercury fixed and fair, which is to be joined to the oil of the Lion; and this work is much shorter and less laborious.

#### **The Calcination Of Antimony Into The Red Lion**

Take Antimony, well ground, so much as you please and melt it in naked fire with Salt Armoniack; and when it is melted, cast it suddenly into a vessel almost full of distilled Vinegar, wherein Salt Armoniack hath been dissolved; and thus melt it and cast it three times. Then pour off the Vinegar from the calx of the Antimony and dry it well and grind it small and dissolve it as before is taught, and so have you the Red Lion of the philosophers' Lead or Antimony.

#### **The Rosie Crucian Medicine Or Elixir Of Copper**

I will make plain the 1. Elixir. 2. Conjunction. 3. Separation. 4. The Medicine. 5. Fermentation. 6. The Earth. 7. Spirit Oil, Blood of the Lamb<sup>206</sup>. 8. Distillation.

9. Resolution. 10. Putrefaction. 11. Solution. 12. Vitriol. 13. Calcination. 14. Copper.

Now many have sought the way of the Mineral Pantarva in Vitriol or green Copperas, but they were altogether deceived, which common Vitriol by the philosophers is called the Green Lion of Fools. But this our noble Red Lion taketh its original from the metallic body of Copper.

Although I am not ignorant how to draw an oil out of Roman Vitriol of a more sweet smell and delightful taste than any balsams if the tincture be taken out of the calcined Vitriol in Spirit of Wine; yet the philosophers' will is to command that it doth consist of a metallic virtue, wherewith the transmutation of metals is to be effected. Therefore they say it is to be made of bodies and not of Spirits, as of Vitriol, Sulphur as well and the like. Whence I find it written in the Philosophers' *Turba*, and in the first exercitation: But the philosophers' Medicine is a metallic matter, converting substances and forms of imperfect metals, and it is concluded by all the philosophers that the conversion is not made except by its like. Therefore it is necessary that the *Presoria* be made of a metallic matter, yet<sup>207</sup> if any be made of Spirits; yet it would be better and much more philosophical and more near to a metallic nature to be made of bodies than of Spirits. But if by art the body should be turned into a Spirit, then the same body would be both body and Spirit, and not to be [regarded as] doubled, but the Medicine might be made of such a body or Spirit. But let me return to our purpose. It being granted that this our Vitriol is such a body according to which Paracelsus testifieth in his *Aurora Philosophorum* under this enigma or secret of the ancient philosophers:

*Visitabis Interiora Terrae Rectificando Invenies Occultum Lapidem Voram Medicinam.*

Out of the first letter of every word of this enigma is gathered this word VITRIOLUM, by which is meant that thereof the Medicine is made.

3. Therefore Paracelsus saith the inward parts of the earth are to be visited; not only the earth, which is Vitriol, but the inward parts of the earth. He meaneth the sweetness and redness, because there lieth hid in the inward parts of the Vitriol a subtile, noble and fragrant juice, a pure oil.

4. And this is especially to be noted: the production of this Copper into Vitriol is not to be done neither by calcination of the fire nor distillation of the matter, lest it be deprived of its grossness, which being lost it wants both power and strength.

5. Paracelsus speaks not one word of the preparation of this Vitriol, by whose silence many have erred; therefore I determined to leave him here a little and to prosecute and follow the order of the Table, wherefore I begin with the calcination of the metal. And note that this calcination of Copper is made that it may be turned into Vitriol, and not the calcination of Vitriol made of Copper.

6. Take therefore as much Copper as you please and dissolve it and calcine it in *Aqua Fortis* to a fair green water; then set it three or four days to digest till the matter be clear, which pour out into a limbeck and *in Balneo* draw away the corrosive water so that the matter remain dry, for then it is calcined.

7. Then upon every two pound of this calcined matter pour a gallon of distilled Vinegar and lute it up in a glass and set it *in Balneo*, almost boiling, the space of seven days, when it is cold put it into a limbeck to distil away all the Vinegar *in Balneo*, and in the bottom of the alembick you shall have your Vitriol very well congealed, far fairer than Roman Vitriol, which is corporeal and metallic Vitriol.

8. Which Vitriol I do not dissolve in rain water like the Paracelsians, but rather with *Lac Virginis* as before is taught, or in Raymund's Calcination Water; and after its dissolution and perfect digestion, that is to say fifteen days, I put it into a limbeck and [*in*] *Balneo* draw off the *Lac Virginis*, which being done you shall find an oily water, green and clear, upon which pour the Spirit of Wine; and after it hath been digested seven days, and the Spirit of Wine distilled away *in Balneo*, you shall find your green water perfectly rectified, made pure, subtile and spiritual, and fit for putrefaction; for if it be not well dissolved and rarefied it will not putrefy.

9. But now I may join with Paracelsus in the manner of putrefaction, I return to him and say with him, commanding to digest in a warm heat in a glass well closed the space of some months, and so long till divers colours appear and be at length red, which showeth the termination of its putrefaction.

But yet in this process this redness is not sufficiently fixed, but is to be more fully purgated from its feces in this manner.

Resolve it or rectify it in distilled Vinegar till the Vinegar be coloured, then filter it from its feces. This is its true tincture and best resolution and rectification, out of which a blessed oil is to be drawn.

This tincture, being thus resolved and rectified is to be put into a body with a limbeck, and *in Balneo* distil the Vinegar gently away.

10. Then in sand or ashes lift up the Spirit gently and temperately, and when you see a fume ascend into the glass and red drops begin to fall out of the nose of the limbeck into the receiver, then the red oil beginneth to distil. Continue your distillation till all come over. When it is done you shall have the oil in the receiver lifted up and separated from its earth, more delightful and sweet than any balsam or aromatick, without any sharpness at all, which oil is called the Blood of the Lamb<sup>208</sup>. In the bottom of the body you shall find a white, shining earth, like snow, which keep well from dust, and so you have the clear earth separated from its oil.

Take this white earth and put it in a glass viol and put thereto equal weight of the oil or Soul and body<sup>209</sup>, which will receive it and embrace it in a moment<sup>210</sup>.

But that it may be turned into a Medicine when you have joined these two together, set it into our furnace the space of forty days and you shall have an absolute oil of wonderful perfection, wherewith Mercury and other imperfect metals are turned into Gold as Paracelsus was pleased to say<sup>211</sup>.

11. The Medicine being thus made, I now come to the fermentation, without which it is not possible to give a form to it; neither will I adhere to the opinion of one man alone contrary to all philosophers, that is to say Paracelsus, repugnant to the rest of the philosophers, because they all of them of necessity have decreed to give form to the Medicine by ferment and union, that is to say of an imperfect body, and by how much the ferment is more spiritual the Medicine will be of so much more penetration and transmutation.

12. These things being promised, I do not think it fit that you should proceed to projection upon Mercury instead of fermentation as Paracelsus teacheth, or that the Pantarva should be fermented his way with Gold, either corporeal or spiritual, which Gold will be the foundation of the first projection.

But what do the philosophers command us to do? That projection, that is to say fermentation, be made of a perfect foundation, and that upon imperfect bodies that Medicine may be made with foundation of the Pantarva or Elixir is not [commanded] except it be only the white or red ferment, in respect of which both Gold and Silver are said to be imperfect bodies. Therefore the Pantarva is to be fermented before it is projected upon the corporeal foundation, or imperfect, that is to say corporeal, Gold.

13. Therefore join this oil to the fourth part of the oil of the Sulphur of Gold, and this is the true fermentation or conversion into the Elixir.

14. Then augment it in virtue by solution and coagulation, and in quantity by projection, first upon its corporeal foundation, that is to say Gold, then that upon purified Mercury and that Medicine upon other bodies which are most fit for projection, that is to say most fusible, as Lead or Tin, which, after they are purified, are most apt by reason of their easy melting.

And thus the inward parts of the earth are visited and by reflection the hidden Medicine is found, the true Medicine out of the Green Lion of the philosophers, and not of fools, and out of corporeal and metallic Vitriol, not terrestrial and mineral Coperas.

### **The Augmentation And Projection Of The Medicines Of Metals Rosy Crucian**

First I will treat of the augmentation of the virtue or quantity of which Raymund saith<sup>212</sup>: The augmentation in quality and goodness is by solution and coagulation of the tincture, that is to say by imbibing it with our Mercury and drying it. But let us hear Arnoldus more attentively. Take one part of your prepared tincture and dissolve it in three parts of our Mercury; then put it in a glass and seal it up and set it in ashes till it be dry and come to a powder; then open the glass and imbibe it again and dry it again; and the oftener you do thus, so much shall you gain more tincture.

And also as it is found in *Clangor Buccinae*. Dissolve it in the Water of Mercury of which the Medicine was made till it be clear; then congeal it by light decoction and imbibe it with its own oil upon the fire till it flow, by virtue whereof it will be doubled in tincture with all its perfections as you will see in projection, because the weight which was before projected upon a thousand is now to be projected upon ten thousand, and there is no great labour in this multiplication. Again the Medicine is multiplied two manner of ways. By solution of calidity and solution of rarity. By solution of calidity is that you take the Medicine, put [it] in a glass vessel and bury it in our moist fire seven days or more till the Medicine be dissolved into water without any turbulency.

By solution of rarity, is that you take your glass vessel with your Medicine and hang it in a new brass pot full of water that boileth, and close up the mouth of the pot that the Medicine may dissolve in the vapour of the boiling water. But note that the boiling water must not touch the glass therein the Medicine is to hang above it three fingers, and this solution will be in two or three days. After your Medicine is dissolved, take it from the fire to cool, fix and congeal and be hard and dry. This do often, and how much the more the Medicine be dissolved it will be so much more perfect; and such a solution is the sublimation of the Medicine and its virtual sublimation<sup>213</sup>, which the oftener it is reiterated, so much more abundantly and more parts it tingeth.

Whence Rasis<sup>214</sup> saith the goodness of the multiplication consisteth in the reiteration and fixation of the Medicine, and by how much more this order is repeated, it worketh so much more and is augmented; for so often as you sublime your Medicine and dissolve it, you shall gain so much every time in projection one upon a thousand; and if the first fall upon a thousand, [the second upon ten thousand] the third upon a hundred thousand, the fourth upon a million and so infinitely. For Morienus the philosopher saith: Know for certain that the oftener our Pantarva is dissolved and congealed, the Spirit and Soul is joined more to the body and is retained by it, and in every time the tincture is multiplied. Whence we thus read in *Scala Philosophorum* [that] which also the philosophers say. Dissolve and congeal. So without doubt is understood of the Solution of the body and Soul with the Spirit into water, and congelation makes the Soul and Spirit mix with the body; and if with one solution and simple coagulation the Soul and Spirit would be perfectly joined to the body, the philosophers would not say

dissolve again and congeal and again dissolve and congeal, that the tincture of the Pantarva may grow if it could be done with one congelation only.

The Medicine is another way multiplied by fermentation; and the ferment to the white is pure Silver and the ferment to the red is pure Gold. Therefore project one part of the Medicine upon two of the ferment (but I say three parts of the Medicine upon one of the ferment) and all will be Medicine, which put in a glass upon the fire and close it so that no air go in nor out, and keep it there till it be subtiliated as you did with the first Medicine, and one part of the second Medicine will have as much virtue as one part of the first Medicine had. (But here again *Clangor Buccinae* hath erred, for it should be writ thus: One part of the second Medicine will have as much virtue as ten parts of the first Medicine had.) And thus by solution and fermentation the Medicine may be multiplied infinitely.

We have spoken enough of this multiplication; we now come to the other way of augmentation, which is called corporeal multiplication, and according to Raymund is thus defined: Augmentation is the addition of quantity; whence Avicen writeth: It is hard to project upon a million and to predicate it incontinently. Wherefore I will reveal one great secret unto you; one part is to be mixed with a thousand parts of its nearest in kind (I call that nearest that is the body of the same metal whereof the Medicine was made or perfected). But to return again to Avicen: Close all this firmly in a fit vessel and set it in a furnace of fusion three days till it be wholly joined together, and the manner of the work is thus projected, one part of the aforesaid Medicine upon a hundred parts of molten Gold, and it makes it brittle and will all be Medicine, whereof one part projected on a hundred of any molten metal converteth it to pure Gold; and if you project it upon Silver in like manner, it converteth all bodies into Silver.

In *Scala Philosophorum* all sorts of projection is set thus down in few words. You must know that first it is said project, that is one upon one hundred etc. Yet it is better to project *nunc dimittis* upon *fundamenta* and *fundamenta* upon *verba mea* and *verba mea* upon *diligam te domine* and *diligam te [domine]* upon *attendite*. This brief enigma is thus expounded; it is nothing else but the words and opinion of the former author concealed under the enigma. Therefore let us repeat the words of the enigma or oracle:

*Nunc dimittis super fundamenta,  
Fundamenta super verba mea,  
Verba mea super diligam te,  
Diligam te super attendite.*

These are trifles for the hiding and concealing [of] the perfection of the art, if the expert could be diverted with such simple words, which, though they are at first [obscure] to [the] young artist, yet they are thus explained. We therefore begin with the first sentence.

*Nunc dimittis super fundamenta*

This is here allegorically taken for the last action almost of the work, which is called the Medicine or Pantarva, which Medicine is to be projected upon the ferment, that is to say upon the oil of Sol or Luna, which are the ferments or foundations of the art in spiritual augmentation (as before was said) upon molten Gold or Silver. And that spiritual ferment converted into Medicine is to be projected upon molten Gold and Silver, which are corporeal ferments in corporeal augmentation and the corporeal fundaments of the art upon Quicksilver.

*Fundamenta super verba mea*

This is spoken also allegorically, because in the adage it is said words are wind, as if a word were nothing else but the motion of the lips and exaltation of the lungs, which no sooner arise from motion but fly away and are turned into air, so likewise Quicksilver or Mercury goeth out of the bodies of the other metals and is so volatile in the fire or heat as words in the air. And therefore Mercury is likened to words upon which the fundaments are to be projected.

*Verba mea (viz. Mercury) super diligam te*

That is to say upon other metals which have most affinity with Quicksilver and [are] easy of fusion, as Saturn and Jupiter, that is to say Lead and Tin, which by this concord and love are easily by the penetration and aimiableness of the Medicine converted into Medicine. And one part of this Medicine converteth other parts of metals into Gold and Silver according to the force and power of the Elixir; which other metals, because they are the substance of the former bodies whereof the Medicines were made, they are the attendants of these Medicines whereof the philosopher commandeth that *diligam te* be projected upon *attendite*, that the second Medicine, or the last, Pantarva upon metal, especially that whereof the Medicine (that is to say the Pantarva) was made, should turn that metal into Gold or Silver according to the property<sup>215</sup> and quality of the Medicine.

But to put an end to this projection, take it according to the opinion of Arnoldus, gathered out of his thirty-first chapter: Who willeth to project one part of the Elixir upon one hundred of Mercury purged, and all will be Medicine, afterwards project one part of this Medicine last congealed upon one hundred parts of Mercury washed, and all will be Gold or Silver according as the Elixir is white or red. Lastly that I may briefly rehearse the absolute manner or projection. First the Medicine is to be projected upon Gold or Silver molten, then upon Quicksilver purged, so long till it turns it into Medicine, and lastly upon metals most near, that they may be converted into pure Gold or Silver according to the properties and quality of the Medicine.

Because we have said something of the propinquity of metals, that is to say that the Elixir is to be projected upon that imperfect body out of which its Mercury and Sulphur was first extracted, therefore it will not be unnecessary to set down one example, that is to say, if the Medicine was made of Mercury, then it is to be

projected upon Quicksilver<sup>216</sup> for making Gold or Silver, because Quicksilver is a near body to Mercury, and so of the rest. Yet it is to be noted that all Elixirs may and ought to be projected upon Quicksilver, because Quicksilver is the mother and sperm of all metals; therefore Quicksilver made and turned into Medicine is to be projected upon a body most near to it, which is Lead or Tin<sup>217</sup>, upon which the Medicine is always to be projected, whether white or red, for the making and transmuting of metals; but both the Quicksilver and Lead are first to be purged that they may be purified and deprived of their filth. Enough hath been said before of the purgation and putrefaction of Mercury.

### **Of The Putrefaction Of Lead**

Melt your lead in a crucible, and when it is melted let it stand in the fire a quarter of an hour, and put therein a little Salt Armoniack, and let it stand a while in the fire and stir it well with an iron spatula till all the Salt Armoniack be gone away in fume; then scrape the skin away out of the crucible that is upon the Lead and let it stand to cool and it will be much whiter and fairer. And thus you must purify your Lead or Tin before projection, because no other bodies are so fusible and apt to melt. Wherefore every Elixir ought to be projected upon Quicksilver and upon Lead or Tin for [the] making or transmuting of metals. But to the end [that] the manner of projection may be yet more plain, I will set down two rules which must be carefully observed.

The first whereof is that the first Medicine, that is to say the Pantarva, be projected upon the ferment always, three parts of the Medicine upon one of the ferment, and one part of this upon ten or one hundred of pure molten Gold, and one part of this Medicine thus made upon 100 parts of an imperfect body, that is to say of Mercury for Medicine.

The latter is that you must always consider the fortitude and debility of your Medicine, for it is to be projected so often upon Quicksilver as it bringeth it into a brittle Medicine, and when it falleth, then project one part thereof upon Lead or Tin for making transmutation according to the order and form of the Elixir.

These being remembered you may easily conceive the order of augmentation in virtue and quantity.

The[se] things being ended, the other three which follow are set down in order because we have spoken before of *Aurum Potabile*, *Argentum Potabile*, or potable Gold or Silver. It is therefore necessary after we have made an end of projection to set down another method of the Elixir of Life in the next place, and after speak of its virtue and power as we find [it] among all the ancient and modern philosophers.

But that we may come at last to the thing intended<sup>218</sup>, observe this manuduction.

You know that no artificer can build, but the earth must be the foundation to his building; for without this groundwork his brick and mortar cannot stand. In the Creation, when God did build, there was no such place to build upon. I ask then, where did He rest His matter and upon what? Certainly He built and founded Nature upon His own supernatural centre. He is in her and through her and with His Eternal Spirit doth He support heaven and earth, as our bodies are supported with our Spirits. This is confirmed by that oracle of the Apostle, *Omnia portat verbo virtutis suae*, He beareth up all things with the word of His power<sup>219</sup>. From this power is He justly styled, *ap irodunamis cai pantadunamis dunamo paos*<sup>220</sup>, The infinitely powerful and the all-powerful power-making power<sup>221</sup>.

I say, then, that fire<sup>222</sup> and Spirit are the Pillars of Nature, the props on which the whole fabric rests and without which it could not stand one minute. This fire<sup>223</sup> is the Throne of the Quintessential Light<sup>224</sup>, from whence He dilates<sup>225</sup> himself to generation as we see in the effusion of the sunbeams in the great world. In this dilation of the Light consist the joy or pleasure of the Passive Spirit, and in its contraction His melancholy or sorrow. We see in the great body of Nature that in turbulent weather, when the Sun is shut up and clouded, the air is thick and dull and our own Spirits, by secret compassion with the Spirit of the Air, are dull too. On the contrary, in clear, strong sunshine, the air is quick and then the Spirits of all animals are of the same rarified and active temper.

It is plain, then, that our joys and sorrows proceed from the dilation and contraction of our inward Quintessential Light. This is apparent in despairing lovers, who are subject to a certain violent, extraordinary panting of the heart, a timorous trembling of the pulse, which proceeds from the apprehension and fear of the Spirit in relation to his miscarriage. Notwithstanding he desires to be dilated, as it appears by his pulse or sally wherein he doth discharge himself, but his despair checks him again and brings him to a sudden retreat or contraction. Hence it comes to pass that we are subject to sighs, which are occasioned by the sudden pause of the Spirit. For when he stops, the breath stops, but when he loseth himself to an outward motion, we deliver two or three breaths, that have been formerly omitted, in one long expiration, and this we call a sigh.

This passion hath carried many brave men to sad extremities. It is originally occasioned by the Spirit of the Mistress or affected party, for her Spirit ferments or leavens the Spirit of the lover, so that it desires an union as far as Nature will permit. This makes us resent even smiles and frowns like fortunes and misfortunes. Our thoughts are never at home according to that well grounded observation, *Animus est ubi amat, non ubi animat*, the Soul dwells not where she lives but where she loves. We are employed in a continual<sup>226</sup> contemplation of the absent beauty; our very joys and woes are in her power; she can set us to what humour she will<sup>227</sup>. This and many more miraculous sympathies proceed from the attractive nature of the fire; it is a Spirit that can do wonders. And now let us see if there be any possibility to come at him. Suppose then we should dilapidate or discompose some artificial building stone by stone; there is no

question but we come at last to the earth whereupon it is founded. It is just so in Magick; if we open any natural body and separate all the parts thereof one from another<sup>228</sup>, we shall come at last to the fire<sup>229</sup>, which is the candle and secret Light of God. We shall know the Hidden Intelligence and see the Inexpressible Face, which gives the outward figure to the body. This is the syllogism we should look after, for he that hath once passed the Aquaster enter the fireworld, and sees what is both invisible and incredible to the common man<sup>230</sup>. He shall discover to the eye the miraculous conspiracy between the fire and the Sun. He shall know the secret love of the heaven and earth and the sense of that deep Cabalism, *Non est planta hic inferiora cui non est stella firmamento superius, et ferit eam stella, et dicit ei: Cresce*. There is not an herb here below, but he hath a star in heaven above, and the star strikes him with her beams and says to him: Grow. He shall know how the fire-Spirit hath his root in the spiritual fire-earth and received from it a secret influx upon which he feeds as herbs feed on that juice and liquor which they receive at their roots from this common earth. This is it which our Saviour tells us, Man lives not by bread alone, but by every word that comes out of the mouth of God<sup>231</sup>. He meant not by ink and paper or the dead letter. It is a mystery, and St. Paul hath partly expounded it. He tells the Arthenians that God made man to the end that he should seek the Lord if haply he might feel after Him and find Him<sup>232</sup>. Here is a strange expression you will say, that a man should feel after God and seek Him with his hands. But he goes on and tells you where you shall find Him. He is not far (saith he) from every one of us, in Him we live and move and have our being<sup>233</sup>. For the better understanding of this place I wish you to read Paracelsus, his *Philosophia ad Athenienses*<sup>234</sup>. Again, he that enters the centre shall know why all influx of fire descends against the nature of fire, and comes from heaven downwards. He shall also know why the same fire, having found a body, ascends again towards heaven and goes upwards<sup>235</sup>.

To conclude, I say the grand, supreme Mystery of Magic is to multiply<sup>236</sup> the fire and place him in the most serene<sup>237</sup> Aether, which God hath purposely created to qualify the fire. For I would have thee know that this Spirit<sup>238</sup> may be so chafed, and that in most temperate bodies, as to undo thee upon a sudden. This thou mayest guess thyself by the Crnsoceraunos, or Thundering Gold<sup>239</sup> as the chemist calls it. Place him as God hath placed the stars in the condensed Aether of His Chaos, for there he will shine, not burn; he will be vital and calm, not furious and choleric. This, I confess, transcends the common people.

Now I will teach the blessed Pantarva Rosie Crucian, their *Aurum Potabile* or the Elixir of life and also the way of making malleable glass.

1. Elixir of Life.
2. Gold dissolved.
3. Silver dissolved.
4. Gold melted.
5. Melted Silver.
6. Projection of the Red Medicine.
7. Projection of the White Medicine.

I have now fully discovered to you the principles of our Chaos<sup>240</sup>. In the next place I will show you how you are to use them. You must unite them to a new life and they will be regenerated by water and the Spirit. These two are in all things; they are placed [there] by God Himself according to that speech of Trismegistus: *Unumquodque habet in se semen sua regenerationis*<sup>241</sup>. Proceed then patiently but not manually. The work is performed by an invisible artist, for there is a secret incubation of the Spirit of God upon Nature. You must only see that the outward heat fails not, but with the subject itself you have no more to do than the mother hath with the child that is in her womb. The two former principles perform all; the Spirit makes use of the water to purge and wash his body, and he will bring it at last to a celestial, immortal constitution. Do not thou think this is impossible. Remember that in the incarnation of Christ Jesus the *quaternarius*, or four elements as men call them, were united to their Eternal Unity and *Ternarius*<sup>242</sup>.

Three and four make seven. This septenary is the true Sabbaoth, the rest into which the creature shall enter. This is the best and greatest manuduction that I can give you. In a word, salvation itself is nothing else but transmutation<sup>243</sup>. Behold (saith the Apostle) I show you a Mystery: we shall not all die, but we shall be changed<sup>244</sup> in a moment, in the twinkling of an eye, at the sound of the last Trumpet<sup>244</sup>. God of His great mercy prepare us for it, that from hard, stubborn flints of this world, we may prove crysolites and jaspers in the new, eternal foundation, that we may ascend from this present distressed Church, which is in captivity with her children, to the free Jerusalem from above, which is the mother of us all.

Hermes, speaking of fermentation, bids us to take the Sun and his shadow<sup>245</sup>. By the shadow he meaneth the Moon, because in respect of dignity, lustre and power she is much more weak and inferior than the Sun. And the Moon followeth the Sun as a shadow doth the body, and is not illuminated except by the light of the Sun. We will first speak of the body, that is to say of Gold, and after come to the shadow, of which Gold it is written in a book of chemical art in this manner: The Rosie Crucian Pantarva is made of Gold alone and only by Nature, and is more sublime than them which the philosophers affirm cureth all infirmities. According to the opinion of this philosopher, I purpose to begin with Gold alone and the Medicine, which is a new and sole nature and ancient and sound Quintessence.

2. But to the end this Gold may be better and more pure, it may be purged two manner of ways, that is to say by Antimony and by dissolution and in corrosive waters with which copper plates are mixed as goldsmiths used to do, which is called Water Gold. When you have thus prepared your gold, project one part of your Red Medicine (or Red Elixir) upon 100 parts thereof, when your Medicine is augmented in virtue and all that weight of molten Gold will be converted into a red, brittle mass, which grind upon a marble to an impalpable powder.

Then dissolve these hundred parts, or so thereof as you please, in distilled Vinegar or in Spirit of Wine, and set it to digest *in Balneo* the space of a day or two. Then distil the Spirit of Wine *in Balneo* and in the bottom will remain the fixed and pure oil of the Gold, which is then true *Aurum Potabile* and spiritual Elixir of Life. If you will give to anyone of this powder presently before it be converted into oil, warm a little white or Rhenish wine and dissolve in either or them so much of the red powder, and the wine so tinctured it will be *Aurum Potabile*, but it would be better and more penetrating if it were tinctured with the aforesaid oil<sup>246</sup>.

In like manner is the White Medicine to be projected after the purification of the Silver in a corrosive water as is before declared.

And so the melted Silver will be converted into a brittle powder and white mass, which likewise is to be dissolved and turned into oil, and then the white Elixir or Life is made and potable Silver, curing and healing, so far as it is able in human diseases, for it cannot be supposed that the Elixir of Luna hath so great virtue as the Elixir of Sol hath, or *Aurum Potabile*.

Now whereas among the vulgar and [also the] philosophers Gold hath this report, that being in his first disposition that it cureth the leprosy and [hath] many other virtues, this is not except by<sup>247</sup> its complete digestion, because the excellency of the fire acting in it consumeth all evil humours that are in sick bodies as well in hot as cold causes. But Silver cannot do this because it hath not so much superfluity of fire and is not so much digested and decocted with natural maturity; yet notwithstanding this, it hath a fieriness occultly and virtually in it, but not so fully, because the fire causeth not such elemental qualities as in Gold. And therefore Silver, being in his first disposition, doth not cure leprosy so potently unless it be first digested by art until it have the chief degrees of Gold in all maturity. Wherefore other sick metallic bodies more weakly cure infirmities according as they differ more from them<sup>248</sup> in perfection and maturity. Some differ more, some less, which is by reason of the Sulphur, infected and burning, of which they were made at the beginning in their generation and coagulation, and therefore they cure not, whereas the fire in them is burning, and so infected with the elemental feces [and] the mixtures of other elemental qualities.

4.<sup>249</sup> Seeing, therefore, that Gold is of such vigour amongst the vulgar, and that being in his first disposition, what wonder is it if it, being brought into Medicine (as is experienced) by art and his virtue be[ing] subtiliated by digestion of decoction and purgation of the qualities, but it may then cure more, nay infinite, of all diseases.

It makes an old man young, as our Rosie Crucian *Aurum Potabile* will do; it preserveth health, strengtheneth nature and expelleth all sickness of the body. It driveth poison away from the heart, it moisteneth the arteries and, briefly, preserveth the whole body sound. The manner of using this Medicine according to all the philosophers is thus: If you will use to eat of this Medicine, then take the

weight of two Florence ducats of our *Aurum Potabile* and one pound of any confection, and eat of that confection the quantity of one dram in the winter. And if you do thus it driveth away all bodily infirmities from what cause soever they proceed, whether hot or cold, and conserveth the health and youth in a man and maketh an old man young and maketh grey hairs to fall; it also presently cureth leprosy and diseases of phlegm, mundifieth the blood; it sharpeneth the sight and all the senses after a most wonderful manner, above all the medicines of the Philosophers.

5. To which purpose we thus find in the *Rosary* of the philosophers. In this (that is to say in this *Aurum Potabile*) is completed the precious gift of God, which is the Arcanum of all sciences in the world and the incomparable treasure (for as Plato saith) he that hath the gift of God hath the dominion of the world (that is to say of the Microcosm) because he attaineth to the end of riches and hath broke the bonds of Nature, not only for that he hath power to convert all imperfect metals into pure medicine and<sup>250</sup> preserve both man and animal in perfect health.

To this purpose speaketh Geberhim, Hermes, Arnoldus, Raymundus Lullius, Ripley, Senotus, Augurellus, Aegidius, Valescus, Roger Bacon, Scotus, Laurentius, Venture and divers uncertain authors.

Lastly, I now come to the general consent of all the philosophers and repeat what is found in their writings in the book *De Aurora Consurgens*<sup>251</sup> and in *Clangor Buccinae*. It is to be noted that the ancient philosophers have found four principal effects or virtues in the glorious repository of their treasure:

- (1) First it is said to cure man's body of all infirmities.
- (2) To cure imperfect metals.
- (3) Thirdly to transmute base stones into precious gems.
- (4) To make glass malleable.

6. Of the first. All philosophers have consented that when the Elixir is perfectly rubified, it doth not only work miracles in solid bodies, but also in man's body, of which there is no doubt; for being taken inwardly it cureth all infirmities. It cureth outwardly by unction. The philosophers also say if it be given to any in water or wine first warmed, it cureth them of the Phrensy, Dropsy and Leprosy and all kinds of fevers are cured by the Tincture, and [it] taketh away whatsoever is in a weak stomach; it bindeth and consumeth the flux of peccant humours being taken fasting; it driveth away the melancholy and sadness of the mind; it cureth the infirmities of the eyes and dryeth up their moisture and blearedness; it helpeth the purblind, red or bloodshot eyes and all other incident diseases are easily cured by the philosophical Medicine of the Rosie Crucians.

It comforteth the heart and spiritual parts by taking [it] inwardly; it mitigateth the pain of the head by anointing the temples therewith; maketh the deaf to hear and succoureth all pains of the ears; it rectifieth the contracted nerves by unction; it

restoreth rotten teeth by washing; also all kinds of imposthumes<sup>252</sup> are cured by it, by ointments or emplaisters or injecting the dry powder therein.

It cureth ulcers, wounds, cancers, fistulas, *noli me tangere*<sup>253</sup> and such like diseases, and generateth new flesh. If it be mixed with corrupt and sour lime it restores it; it expelleth poison, being taken inwardly; it also killeth worms if it be given in powder; it taketh away wrinkles and spots in the face by anointing therewith and maketh the face seem young; it helpeth women in travail being taken inwardly, and bringeth out the dead child by emplaister. It provokes urine and helpeth generation. It preventeth drunkenness, helpeth memory and augmenteth the radical moisture; it strengtheneth nature and also administereth many other good things to the body.

2. Of the second<sup>254</sup> it is written that it transmuteth all imperfect metals in colour, substance, lasting, weight, ductibility, melting, hardness and softness.

3. Of the third, that is to say of transmuting base and ignoble stones into precious.

4. Of the fourth it is writ that it maketh glass malleable by mixture (that is to say, of the powder of the white corporeal Elixir) when the glass is melted.

Thus far *Aurora Consurgens* and *Clangor Buccinae*.

Now if you desire to make pure and malleable glass, beware of what glass you make your metal; for you must not take glass of flint, wherewith glass of windows are made, but such as your Venice glass is made of, and that is to be chosen out of the first metal of the glass which hath stood molten in the fire in the glass-maker's furnace the space of a night, and then it will be spots and pure. Therefore take as much of the said glass out of the furnace with your iron rod as you have a desire to convert, and when it is cold weigh it and melt it by itself in a pot; and when it is molten, project your white corporeal Elixir upon it and it will be converted into malleable metal and fit and apt glass for all goldsmith's operations. And thus is glass made malleable and prepared for any use; but if this were done with the red Elixir it would be much more during, for there is nothing more precious.

To perfect the Great Work which all philosophers have concealed, observe my direction which by experience I have found true. To calcine, dissolve and separate the elements. After join them together, putrefy them or reduce them into Sulphur; ferment, project, augment in virtue and quantity. This is the work of the philosophers.

This subject<sup>255</sup> I call *Limus Coelestis*<sup>256</sup> and the Middle Nature. The philosophers call it the venerable nature, but amongst all pretenders I have not yet found one that could tell me why. This chaos hath in it the four elements, which of

themselves are contrary natures, but the wisdom of God hath so placed them with their very order reconciles them.

For example air and earth are adverseries, for one is hot and moist, the other cold and dry. Now to reconcile these two God placed the water between them, which is a middle nature, or of a mean complexion between both extremes. For she is cold and moist, and as she is cold she partakes of the nature of the earth, which is cold and dry; but as she is moist she partakes of the nature of air which is hot and moist. Hence it is that the air and earth, which are contraries in themselves, agree and embrace one another in water, as in a middle nature, which is proportionate to them both and tempers their extremities.

But verily this *sa/vo* makes not up the breach; for though the water reconcileth the two elements. like a friendly third, yet she herself fights with a fourth, namely with the fire. For the fire is hot and dry, but the water is cold and moist, which are contraries.

To prevent distemper of the two, God placed the air between them, which is a substance hot and moist; and as it is hot it agrees with the fire, which is hot and dry; but as it is moist it agrees with the water which is cold and moist, so that by mediation of the air the other two extremes, namely fire and water, are made friends and reconciled. Thus you see, as I told you at first, that contrary elements are united by that order and texture wherein the wise God hath placed them. Now I tell you that this agreement of friendship is but partial, a very weak love, cold and skittish; for whereas those principles agree in one quality, they differ in two as you may easily compute. Much need, therefore, have they of a more strong and powerful<sup>257</sup> mediator to confirm and preserve their weak unity; for upon it depends the very eternity and incorruption of the creature<sup>258</sup>. This blessed cement and balsam is the Spirit of the Living God, which some ignorant scribblers have called Quintessence, for this very Spirit is in the Chaos, and, to speak plainly, the fire is<sup>259</sup> His Throne<sup>260</sup>, for in the fire is He seated. This was the reason why the Magi called the First Matter their Venerable Nature and their Blessed Stone. This Blessed Spirit fortifies and perfects that weak disposition which the elements already have to union and pace (for God works with Nature and not against her) and brings them at last to a beauteous, specific fabric. Now if you will ask me, where is the Soul, or as the schoolmen abuse her, the form, all this while? What doth she do? To this I answer that she is all instrumentals ought to be, subject and obedient to the will of God, expecting the perfection of the body. For it is God that united her to the body and the body to her.

Soul and body are the works of God, the one as well as the other. The Soul is not the artificer of the house, for that which can make a body can also repair it, and hinder death; but the Soul cannot do this, it is the power and wisdom of God. In a word, to say that the Soul formed the body, because she is in the body is to say that the jewel made the cabinet or that the Sun made the world and cherisheth

every part thereof. Learn, therefore, to distinguish between Agents and their instruments, for if you attribute that to the creature which belongs to the Creator, you bring yourselves in danger of hell fire, for God is a jealous God and will not give the glory to another.

If thou dost know the First Matter, know also for certain thou hast discovered the Sanctuary of Nature. There is nothing between thee and her treasures but the door; that indeed must be opened. If thy desire lead thee on to the practice, consider well with thyself what manner of man thou art, and what it is that thou wouldst do; for it is no small matter. Thou hast resolved with thyself to be a co-operator with the Spirit of the Living God and to minister to Him in His work of generation. Have a care, therefore, that thou dost not hinder His work; for if thy heat exceeds the natural proportion, thou hast stirred the wrath of the moist natures and they will stand up against the central fire and [the central fire] against them and there will be a terrible division in the Chaos; but the sweet Spirit of Peace, the true eternal Quintessence, will depart from the elements leaving both them and thee to confusion; neither will He apply Himself to the Matter as long as it is in thy violent, destroying hands.

I will now lay down plain instructions concerning:

1. The Elixir of Saturn.
2. Putrefaction into Sulphur.
3. The Oil, of the Sulphur.
4. Of the Conjunction.
5. Of the Salt.
6. Of Oil of the Spirit.
7. Of Salt of Saturn, which containeth the Oil or Soul of the *Menstruum*.
8. Of White Mercury.
9. Of Red Water of Paradise.
10. Resolution.
11. Solution.
12. Distillation.
13. Hyle.
14. Purgation.
15. Resolution.
16. Of Sericon.
17. Of the Gum.
18. Of Sericon.
19. Of the Solution.
20. Of Minium Or[e].
21. Adrop.
22. Of Calcination.
23. Of Minium.
24. Adrop.
25. Of Red Lead.
26. Of Calcination of Lead.
27. Of *Aqua Fortis*.

Now<sup>261</sup> see which way the philosophers move. They commend their secret water and I admire the tears of *Beata Pulchra*<sup>262</sup>. I will tell you truly what she is; she is not any known water whatsoever, but a secret spermatic moisture, or rather the Venus, that yields that moisture. Therefore do not you imagine that she is any crude, phlegmatic, thin water, for she is a fat, thick, slimy humidity. But lest ye should think I am grown jealous and would not trust you with my mistress, Arnoldus de Villa Nova shall speak for me. Hear him. *Amplius tibi dico, quod nullo modo invenire potuimus, nec similiter invenire potuerunt philosophi, aliquam rem perseverantem videmus de facili evaporare, arida remanet, et ideo separantur, quia non sunt naturales. Si autem eas humiditates consideremus, quae difficulter separantur ab his quae sunt naturales, non invenimus aliquas nisi unctuosas et vi scosas.* I tell thee further (saith he) that we could not possibly find, neither could the philosophers find before us, anything that would persist in the fire, but only the unctuous humidity. A watery humidity, we see, will easily vapour away, and the earth remain behind, and the parts are, therefore, separated, because their composition is not natural. But if we consider those

humidities which are hardly separated from those parts which are natural to them, we find not any such but the unctuous, viscous humidities.

This viscous humidity<sup>263</sup> is Water of Silver, which some have called Water of the Moon; but it is Mercury of the Sun and partly of Saturn, for it is extracted from these three metals and without them it can never be made<sup>264</sup>.

Very many have written of Saturn or Lead, but none that I know of have written fully thereof in any particular treatise. Therefore I do not only here set down what I have gathered from them most briefly and truly, but also those things which I have found and proved by my own experience, which I have annexed to them that the work may be absolute and complete.

Of which, as they say, Mary the prophetess, the sister of Moses, in her *Books of the Work of Saturn* is said to write: Make your water running like the water of the two Zaibeth<sup>265</sup> and fix it upon the Heart of Saturn. And in another place: Marry the Gum with the true Matrimonial Gum and you shall make it like running water; of which process of Mary, George Ripley hath these verses:

*Maria mira sonat  
Quae nobis talia donat  
Gummis cum binis  
Fugitivem fugit in imis  
Horis in trinis  
Tria vinclet fortia finis  
Filia plutonis  
Confortia jungit Amoris*

The Heart of Saturn, you shall find why is his body white and clear; the work is briefly thus described. That a water be made out of the body of Saturn like the water Zaibeth, and that water fixed upon the Heart of Saturn. The direction for drawing out the water of Zaibeth and the way of making the Heart of Saturn is hereafter at large declared, with reduction of the body of Saturn into his Heart or Salt.

Note the power of Saturn and his Angel upon earth, Cambiel, Hanael, Cancer, Tristitia, and Lead thus prepared for Medicines and Telesmas. You see here the wonderful power of God, how he rules heaven and earth by ten names, ten Sephiroth, ten orders of blessed Souls, ten Angels in their ten Spheres, seven Angels that carry their power to seven planets and the earth; and here we teach you knowledge of the seven metals and the miraculous Medicines of the Rosie Crucians.

Having thus described the work, I now come to the explanation and say that the calcination of the body is two-fold, for the calcination thereof in the shorter work for extracting the Heart of Saturn is done on any wise by *Aqua Fortis*.

Take eight or ten ounces of Lead in filings and dissolve it in *Aqua Fortis* in double proportion and justified with Salt Armoniack in an earthen vessel with a narrow neck and set in ashes till it be totally dissolved; and there will remain a white matter in the bottom like grains of white Salt, which is a figure of perfect solution. Then pour your matter that is dissolved in the water into a body and set thereon a limbeck and *in Balneo*, draw away the corrosive water till there remain a dry substance in the bottom, and so you have the body converted white by calcination with corrosive water out of which the Heart of Saturn is to be drawn.

7. The way to wash away and purge the corrosive water from the body. Pour warm water upon the substance in the limbeck and pour it often off till it have no sharpness at all upon the tongue and then the body is prepared for drawing out the Salt.

8. When your matter is well dried, dissolve it again in distilled Vinegar and distil the Vinegar twice or thrice from it and in the bottom you shall have a lucid, clear and white, shining Salt, which is called the Heart of Saturn.

9. Now I come to the practice of the other greater work, that the verity of the Medicine may be found, of which many have made mention in their books, as Raimundus, who called it the Vegetable, Mineral and Animal Medicine. Geber saith there groweth a Saturnian Herb on the top of a hill or mountain, whose blood, if it be extracted, cureth all infirmities<sup>266</sup>.

10. Ripley writ a whole book called his *Practical Compendium*, of the practice of the Vegetable Medicine, teaching the manner and form of operation; but because he neither set down the solution plainly nor perfectly, he hath been the cause of much error and hath not only deceived me, but all those that followed him, until after a long time I found a way to dissolve Saturn, so that it could never after by distillation be turned into Lead again, which is the choicest and greatest secret of the Vegetable Medicine.

11. But let us hear the words of Mary the prophetess and Ripley taken from her: The Radix of our Matter is a clear and white body, which putrefieth not but congealeth<sup>267</sup> Mercury or Quicksilver with its odour, makes its water like the running water of the two Zabieth (or Zubech) and fix[eth] it upon the fixed Heart of Saturn. Which words do most aptly agree with the properties of Lead, for if anyone be shot or wounded with a bullet and the bullet remain in the body, it will never putrefy.

12. And also if Quicksilver be hanged in a pot over the fume of molten Lead, so as the fumes of the Lead touch the Quicksilver, it will congeal it.

13. Thus far of the preparation of Lead. We now come to its denomination. They bid us fix the water [of] Zabieth upon the fixed body of the Heart of Saturn. Now for the exposition of the body for the name of Saturn. Ripley called it Adrop<sup>268</sup>, of which that is made which the Masters call Sericon<sup>269</sup>, the water of Sericon they

call their *Menstruum*. The two Zabrieths joined together in one water<sup>270</sup> are the two Mercuries, that is to say white and red, contained in one *Menstruum*, that is to say of the water and oil of the fixed body or Heart of Saturn.

14. Isaacus also writ a treatise of Lead. He worketh chiefly according to the doctrine of Mary the prophetess and laboureth much to fix the earth of Saturn and after to dissolve the body in distilled Vinegar, that by the addition of corroding the sharp things his red oil may be distilled, which he called the Water of Paradise, that he may imbibe his fixed earth therewith: which way is much shorter than Ripley's, but the rubification and fixation of the earth is long and uncertain; wherefore I have both forsaken Isaacus and Ripley in making the earth, instead of which I have given the fixed Heart of Saturn.

15. But that the body may be prepared according to this Table and after my intention and the desire of Ripley, we both will that the pil or Water of Paradise be drawn out of the Gum of Sericon (whose father is Adrop). Sericon is made of red Lead; therefore it is first necessary to show the way of making Minium of Lead. Take the description as followeth and therewith the composition of the Gum of Sericon.

16. Take ten or twelve pounds of Lead and melt it in a great iron vessel as plumbers use to do; and when it is molten, stir it still with an iron spatula till the Lead be turned to powder, which powder will be of a green colour. When you see it thus, take it from the fire and let it get cool and grind that powder upon a marble till it be impalpable, moistening the powder with a little common Vinegar till it be like thick honey, which put into a broad earthen vessel and set it on a trevet over a lent fire to vapour away the Vinegar and dry the powder and it will be of a yellow colour. Grind it again and do as before, till the powder be so red as red Lead, which is called Adrop. And thus is Saturn calcined into red Lead or Minium.

17. Take a pound of red Lead and dissolve it in a gallon of Vinegar and stir it with a stick three or four times in a day. Then take your earthen vessel and set it *in Balneo* twenty-four hours then let it cool and filter the liquor three times; and when it is clear put it in a bottom [and distil away the Vinegar when] the Gum of Sericon will remain like thick honey; which set apart and dissolve now more Lead as before for more Gum till you have ten or twelve pound thereof.

18. Now give careful attention, for we now come to the point and period of Ripley's error; for if you put four pounds of this Sericon to distil in a limbeck, and from thence would draw a *Menstruum* as Ripley teacheth, perhaps you would have scarce one ounce of this oil, and some part of a black earth will remain in the bottom and most of the Gum melted again into Lead, by which you may know that the Sericon is not well dissolved, nor as yet sufficiently prepared that a Chaos may be made thereof fit for distillation because it is not yet well dissolved. Therefore in Isaacus there is found a way, resolving this Gum with distilled Vinegar acuated with calcined Tartar and Salt Armoniack; wherefore, saith he, if

thou be wise resolve the Gum. But I like not this acuation of the Vinegar as I may call it. I rather choose to resolve the Sericon in Raymund's Calcination Water, which is a compound water of Vegetable Mercury, or fire natural, with the fire against nature, as Ripley testifieth; and it is more verified by Raymund in his books of Mercury, where he teacheth how to dissolve bodies with his Calcivative Water.

19. I will reveal unto you this water, which is almost unknown. Note, therefore, that the Vegetable Mercury is the Spirit of Wine (instead of which we may sometimes use distilled Vinegar) and that the Fire against Nature is a corrosive water made of Vitriol and Saltpeter.

20. Therefore take which you will, either Spirit of Wine rectified (or *Aqua Vitae*) or distilled Vinegar four pounds and two pounds of corrosive water and mix them together.

In this water thus compounded, resolve half a pound of Gum of Sericon in a circulatory and set it *in Balneo* four or five days, and the Gum will be totally dissolved into the form of water or oil of a duskish red colour.

21. Then distil away the water *in Balneo* and there will remain an oil in the bottom which is the Chaos out of which you may draw a *Menstruum* containing two elements, and this is the true resolution of the Gum of Sericon. In this water you may resolve so much Gum as you please by reiteration.

22. Take two pound of this Chathodical substance and prepare it for distillation in naked fire or sand, and lift up the clear red oil, wherein both the Spirit and Soul secretly lie hid, which Isaacus calleth the Water of Paradise, which, when you have [it], you may rejoice, for you have gone through all the gross work and come to the philosophic work.

Therefore proceed to conjunction and join the white Heart of Saturn with the red oil as it is found in the *Rosary, candida succinto jacet uxor nupta marits*, that is to say the red Mercury to the Salt if you proceed to the red work.

23. Therefore take four ounces of the Salt or Heart of Saturn and as much of the red oil or Water of Paradise, and seal them up in a philosophers' egg; and so soon as they shall feel the heat of the *Balneum*, the Salt will dissolve and be made one with the oil so as you shall not know which was the Salt nor which was the oil.

Set your glass *in Balneo* and there let it stand in an equal degree of fire till all your matter be turned white and stick to the sides of the glass and shine like fishes eyes<sup>271</sup> and then it is white Sulphur of Nature. But if you proceed to the red work, then divide your white Sulphur into equal parts, reserving one part for the white work, and go on with the other part, and in a new glass, well sealed up, set it in ashes till it is turned into a red colour.

24. When your Sulphur is thus converted, imbibe it again with equal weight of its Soul, dissolving and congealing till it remain in an oil and it will congeal no more, but remain fixed and flowing.

This then is to be fermented with the fourth part of the Oil of Gold.

We have set down already before of the augmentation in quantity and quality, therefore it is not necessary to repeat it here.

We will now return to the white Sulphur before reserved, that we may set down the manner of the white work.

When you have your red oil or Soul, if you desire to make the white Elixir, set part of the said oil in a glass *in Balneo* to digest. Then take it out and put it into a body and in a lent fire distil away the Spirit or white Mercury, which you must try and know whether it arise pure without water or not, as you do when you try the spirit of wine. For if it burn all up it is well; if it do not, rectify it so often till it be without any waterings at all; then have you rectified your Spirit, wherewith dissolve your white Sulphur till it remain fixed and flowing as you did before in the red work. Then ferment it and augment it with the fourth part of the oil of the white Luminary or Luna, as you did the red, and it will be the white Elixir, converting imperfect bodies into perfect Silver.

25. Ripley divided the scope of this work into four operations, whereof the first is the dissolution of the body; the second the extraction of the *Menstruum* and the separation of the elements; the third is not necessary in our work, because we cast away the earth after every distillation, instead of which we use our Salt or Heart of Saturn; the fourth is that there be a conjunction of our Salt as is before described.

#### **Here Followeth The Accurtation Of The Work Of Saturn**

The way of extracting Quicksilver out of Saturn found in Isaacus, of which I know how to make a special accurtation with his Water of Paradise, which I gathered partly from the aforesaid writer and others. Ripley made his accurtation with Quicksilver precipitated with Gold and imbibition with corrosive water, which I like not, because the Elixir so made will be the greatest poison, as himself confesseth that it were better for a man to eat the eyes of a Basilisk than taste that Elixir.

26. But because I desire to set down this accurtation of Lead alone with his elements, that no strange body may be added to our Elixir, and also that it may be made a Medicine for all uses, I have found out the way of making [it] alone with the Mercury of Saturn and his own proper Tincture; for I make a body of one thing, which is a Spirit, and make that Medicine with its own proper Spirit. Read all the philosophers and you shall never find a word of this process, nor none of the ancients will teach how to make the Mercury of Saturn.

### **Of the Medicine, Elixir, Fermentation, Imbibition, Precipitation, Quicksilver, Saturn, Lead, The Toad**

Sir Christopher Heydon saith in a manuscript of his; *Levi enim arte norunt Alchemistae Mercurium currentem conficere ex plumbo*. The Alchemists know how by an easy art to make current Mercury out of Lead. But what art that was no author of the ancients hath showed unto us. *Quaevite, quaevite*, saith the first alchemist<sup>272</sup> (so Paracelsus was pleased to say in imitation of him) *et invenietis, pulsate et operietur vobis*. I tried many experiments, although they were repugnant to doctrine and philosophy; I almost despaired of that art; yet because nothing is difficult to the industrious, by often knocking at last I found it apart, by which means I attained to the art of such a felicity, that is to say of making Quicksilver of<sup>273</sup> Lead. This art revealed is a great secret. The instruments necessary in this work are<sup>274</sup> a furnace, a crucible and a pair of tongs. Let the furnace be filled with coals, whereunto put fire, and when the coals are well burnt, so that they give a clear flame and fire, take your crucible, well annealed so that it break not with the sudden heat, and put therein three ounces of filed Lead, having twelve ounces of Mercury sublimate well ground, and Salt Armoniack six ounces, mixed together, which put upon the filings of Lead in the crucible, and when the fire is strong and glowing hot, take your tongs and presently take up your crucible and put it into the hole in the top of the furnace till you hear a great noise and buzzing; then so soon as you can (lest the Quicksilver fly away with the Spirits) take away the crucible with the matter therein and set it in an earthen dish filled with ashes to cool; and when it is cold, strike the lower part of the crucible so that the matter of the Lead may fall into an earthen dish, and you shall find your Lead converted into Quicksilver.

Take of this Quicksilver so much as you please and put it to precipitate in a round glass, well luted; and set it in ashes to the top of the glass. Yet let us stay here a little while [that] the understanding may be more enlightened.

Therefore understand that the intention of this work is to fix the Spirit, which may sooner be done with the Spirit of a fixed body, which before was homogeneal with the body, and which of its own nature desireth to join again with its body.

Therefore Nature requireth that she may be helped by art in this work, to which the artist consenting, he administereth thereto the pure and desired metal, which it delighteth to adhere unto, which metal is Gold, which is thus prepared that it be sooner parted by the Quicksilver and stick thereunto.

Take as much pure Gold as you please and dissolve it in *Aqua Regis* mixed with equal part of *Acetum acerrimum* or *Lac Virginis*. Then set it to digest the space of a day; then put your dissolution into an alembick and set it *in Balneo*. So distil away the water as dry as you can and do thus three times and the third time distil it in ashes that the Salt Armoniack may sublime. Then put distilled Vinegar upon the matter remaining, and after it hath stood three days *in Balneo*, distil the Vinegar away in ashes that all the substance of the Salt Armoniack may sublime,

and do thus three times, always putting in new Vinegar, until the oil of the dissolved Gold remain in the bottom. Then take of your Quicksilver three times so much as your Gold and pour it upon the solution of the Gold that they may mix together and be united. Then put your Quicksilver with the solution in a round glass, stopped only with a piece of cotton, and with a stick put it down every day as it doth ascend; and keep your glass in ashes for a month till your Quicksilver be turned into a red precipitate. Then again dissolve it in new distilled Vinegar till the whole substance of the Quicksilver be dissolved and the Vinegar be coloured into a golden colour; then distil away the Vinegar in ashes and again precipitate the Quicksilver, which is in the bottom of a gold colour, into a red and fixed body, and so have you the Mercury precipitate of Saturn.

It remaineth now that the body be imbibed with its Soul, that thus being from a Spirit reduced into a body [it] may again imbibe its Soul that it may be dissolved herewith. Therefore put it into a glass and add thereto equal proportion of its Soul or Water of Paradise, and shut your glass well the space of five days till the body be dissolved with the Soul.

Then dry it in ashes till it penetrate and flow; and when it is dried, try it upon a hot iron plate if it be fixed and melt, if not, imbibe it again with half the weight of its water and do so till you make it fusible and piercing by imbibing and drying. And when it will melt in the fire and penetrate, it is then the Medicine and fit for fermentation. And after the fermentation it will be the Elixir.

Then it is to be augmented and projected as is before declared, and thus the work of Saturn is accurtated, of which George Ripley saith: Adrop is the father of the Medicine, Sericon his brother, Lympha his sister, the earth its mother.

But if you desire to know all the secret of Saturn or Lead, I will set you down one process out of Paracelsus: When you have well prepared the Heart of Saturn, saith he, take two or three ounces of that Heart and grind it small with double [the] weight of Saltpeter and put it in a subliming glass with a head well luted to sublime, increasing the fire by little and little as long as anything will ascend or sublime. Thus far Paracelsus. Now if you would find this true, Ripley will tell you what you shall do in these words.

When by the violence of the fire in the distillation of the Gum of the Sericon, a certain white matter shall ascend sticking to the head of the limbeck, like ice, keep the matter, which hath the property of Sulphur, not burning, and is fit matter for receiving form. You shall give it form after this manner by rectifying it in ashes; and when it is red Sulphur, give it of its Soul until it pierce and flow, then ferment it.

Here I have delivered unto you all the ways and manners of Saturn which are found in any of the philosophers' books. To the end, therefore, that the work may be completed with a demonstration of this word *Plumbum Philosophorum* as

appears in the *Practical Compendium* of Ripley, I say that the philosophers' Lead is not taken for Antimony but for Adrop, being converted into the Gum of Sericon.

The influence of Jupiter and his Angel upon Hismael, Advachiel, Aquisitio, Letitia and Tin, by art and nature fitted for man's use. Jupiter followeth Saturn's steps, for he is the offspring of Saturn and naturally born from him.

*presentat Stannum sub quo aliquando Mercurius Sublimatus et Sal Ammoniarum intelligitur. Cineritius ille probus justus Jupiter influentiam suam habet in terrestrem Jovem, qui post preparationem suam, se claro serio suavi cum sale Sulphureque lunari ostentat, et mortalibus virtutes suas presentat. Habet quoque specialem suam influentiam bonus ille Jupiter in Jecur, sanat propterea illud, omnesque affectus qui inde oriuntur.*

### **To Make the Elixir of Iron**

Observe in this work 1. Calcination. 2. Solution. 3. Separation. 4. Conjunction. 5. Putrefaction. 6. Sulphur. 7. Fermentation. 8. Elixir.

Mars being most earthly of all the planets or bodies, it is not to be doubted but that it may easily be reduced into a body with little labour and therefore most easily converted into Salt, which is done by Calcination; therefore I will first show his conversion into Salt. Understand therefore that hence ariseth a two-fold consideration, that is to say that it be calcined one way into its body or Salt, the other way that the body be prepared for solution by calcination.

The practice differs but a little, for whether you calcine Iron for its *Salt* or *Menstruum*, one only manner of preparation<sup>275</sup> sufficeth.

That is to say, that you take filings of Iron or Steel, as much as you please, and mix these with equal weight of Sulphur in an earthen body with a limbeck well luted thereto; then set it in ashes to sublime till all the Sulphur be sublimed from it; then dissolve the filings which remain in the bottom in *Aqua Regis* and it will be converted into Salt, which will be cleansed from the said water if you put thereon distilled Vinegar and distil it away. Do thus three times with new Vinegar and you shall have a yellowish-red Salt in the bottom which then is a body to be joined to the Soul, which keep in warm ashes till you use it.

Now for the practice of Iron for dissolution. Take filings of Iron or Steel, so much as you please, and put it in an iron dish filled with Vinegar and set it in the flaming fire the space of three hours; then take it out and let it cool. Reiterate this work four or five times, then calcine it with Sulphur as you did before.

When it is thus calcined, set it to dissolve in a corrosive water by adding equal weight of our *Acetum acerrimum*, and let it stand till it have dissolved so much as it can in the cold; then set it in hot ashes and let it stand there the space of four or five days. Pour off the water and dry [that] which is not dissolved, and again

calcine it and dissolve it; and when it is dissolved, so as the water be coloured red, pour it out into a body and keep it till you have dissolved as much calcinated Iron as you please.

Then take<sup>276</sup> all your dissolution, and with an alembick distil away the water *in Balneo* and put distilled Vinegar upon the matter remaining in the bottom and let it stand upon it *in Balneo* the space of seven days; then take out your glass and filter the dissolution and then again *in Balneo* distil off the Vinegar and in the bottom will remain a thick oil of Iron or<sup>277</sup> Steel. But if it be not dissolved to your mind, reiterate your solution in Raymund's Calcination Water, but it would be better if it wereedulcorated<sup>278</sup> with *Aqua Vitae*, drawing it away again in *in Balneo*, and so you have Iron dissolved into a liquor.

Therefore proceed to distillation, that there may be a separation, and distil it in an earthen vessel in a strong fire increasing the fire as much as you can and receive the oil or Soul or red tincture of Mars, separated from the remaining feces by the nose of the limbeck, which oil is the most permanent tincture for colouring Sulphur for the red work or for exaltation of all Elixirs in colour, for it makes it tinge and colour higher.

When you have thus prepared the tincture, then proceed to conjunction and work with the Salt before reserved, taking three or four ounces of the Salt and equal weight of the Soul.

Then seal it up and set it to putrefy *in Balneo*, and keep it there till it pass through all colours and be white, and then it is Sulphur of Nature.

The nature of Mars and his Angel upon Barzabel, Malchidael, Barchiel, Puer, Rubeus and Iron, with the mixtion of elements. The Medicine must be made when Mars ascends in Aries or Scorpio in the hour of Mars, Puer projected in the Ascendent.

Then take out your glass and set it in ashes in a greater degree of heat till it be red; then dissolving the red Sulphur with its own Soul and again dissolve and fix it; dissolving it *in Balneo*, fixing it under the fire, and so it is prepared for fermentation.

The fermentation is, as hath often been spoke of before, with the resolved oil of the Sulphur of Gold in a four-fold proportion to the Medicine, that by the addition of the ferment it may be made Elixir transmuting all bodies.

And note that the Elixir of Iron excelleth all other Elixirs, for it rubifieth more and tingeth higher and is better for man's body, for it prevaieth against the spleen, constringeth the belly and cureth wounds; it knitteth broken bones together and stoppeth the superfluous flux of the courses etc.

### **I Will Now Show The Operation Of The Physical And Alchemical Tincture Of The Red Lion And Glue Of The Eagle**

It is chiefly to be remembered how I taught you to dissolve Antimony with our *Acetum acerrimum*, which may be also well done if you dissolve it in our Calcination Water; and after that Antimony is calcined, which hereafter shall be at large treated of, also of the Glue of the Eagle. You must understand that we attribute no other beginning to this accur[t]ation except that where before we took the Blood of the Red Lion and the Glue of the Eagle when they were both destroyed, we now join them sound and not hurt together, that they, living, may mortify and dissolve themselves, which I have fitly called Corporeal Matrimony or the Union, for in this wedlock they die together that they may be vivified in the Celestial Antimony. It is not to be wondered if this [work] differ from the other, for this pertaineth to the handling of Spirits, the other way to teacheth the manner of making the Elixir of bodies.

That I may plainly reveal all things unto you, take Antimony well ground, half a pound, and as much Mercury Sublimate likewise well ground, and grind them both together upon a marble till you cannot know them one from the another; then set them in a cold place that the matter dissolving may drop into a glass set underneath, for when the matters are well mixed together, then [I] say that they will both shortly be dissolved; when the water is perfectly dissolved it will be of a greenish colour and loathsome smell.

Put this water with the thick part within into a glass, and let it stand the space of three days in a fixatory under the fire, and in [a] short time you shall have your dissolvedness of a brownish black colour, and after, that is to say in the aforesaid time, it will be red, something higher than red Lead.

Dissolve this calcined matter in Raymund's Calcivative Water, and when you have dissolved it all into a red liquor, or deep yellow, then is your matter brought well into its Chaos.

Put this liquor into a fit body with an alembick and receiver, and by distillation separate the red oil or the red Mercury from the white body which remaineth in the earth, and if any matter ascend into the head of the alembick, despise it not, but try if it [be] fixed; and if it be not fixed enough, sublime it till it be fixed.

Whereunto join equal weight of its Soul, for the Celestial Matrimony, and always leave out the earth in the bottom if you have any sublimate fixed; if not, take the white earth remaining in the bottom, with which proceed as before is said, and join the white body with the Soul. When they are thus joined or married, set them to impregnate and revivify *in Balneo* till it pass through all colours and at last be converted into red, which then is Medicine.

The manner of fermentation [and] augmentation, both in quantity, quality and projection, is spoken already.

And thus I have opened many choice secrets of the ancient philosophers, and also have amended many things in them. Their writings were rather published to conceal the art than to make it manifest or teach it. Although it pleaseth Hermes Trismegistus, the first writer of this art, both to say and protest that he had never revealed, taught nor prophesied anything of this art to any, except fearing the Day of Judgement or the damnation of his Soul for shunning the danger thereof, even as he received the gift of faith from the Author of faith, so he left it to the faithful. Yet when you read his writings either in his *Smaragdine Tablet* or in his *Apocaled* or his *Twelve Golden Gates* and shall find nothing plain, what shall ye think of such an author? Believe me, all the ancients have concealed the secret of their preparations in the gross work, although they writ most famously of the philosophic operation; therefore I have used my endeavour to try, for out of their writings I found that the Elixir might be made of the planets or metals, and also of mean minerals, which came near to a metallic nature. Then, reading more, I found a certain method amongst them all, as it were with one consent or voice on this wise.

First and principally that bodies should be made incorporeal, that is to say discorporated or discompounded, which then is called Hyle or Chaos. Secondly that out of the Chaodical substance, which is one thing, three elements should be separated and purified.

[Thirdly] that the separated and purified elements should be joined, the man and the woman, the body and the Soul, heaven and earth, with infinite other names so called that the ignorant might think they were divers, which only were nothing else but water and Salt, or the Body and Spirit or Soul, that is to say white Mercury and Red, which they joined together that a new and pure body might be created in putrefaction and a Microcosmical infant might be created in imitation of the Creation, that is to say, Sulphur of Nature<sup>279</sup>.

Fourthly that it should be fed with Milk, that is to say that its own proper tincture, and after[wards] nourished by fermentation, that it may grow to its perfect strength.

Having learned these I began to practise, and in the practice of every body and Spirit I found divers errors; but reading more and trying more, I at last found the manner and true way of dissolving all bodies, separating and conjoining them, finding the composition of their secret of secrets, that is to say *Lac Virginis* or *Acetum acerrimum*, and Raymund's Calcining Water, wherewith I dissolved all bodies at pleasure and perfected the gross work. Wherefore I purposed, contrary to<sup>280</sup> the customs of the philosophers, [to] reveal the whole work lest I, being envious, should be the author of errors like themselves. Therefore I have added their secrets to my own experiments and inventions, which are plainly and truly writ.

Alchemy revealeth and openeth unto us four other secrets.

The first is the Composition of Pearls, far greater and fairer than natural ones, which cannot be perfectly done without the help of the Elixir.

The second is the manner of making precious stones out of ignoble ones, by the same art as we made malleable glass.

The third is the manner of making artificial Carbuncles in imitation of natural ones, which few or none have spoken of.

The fourth is the manner of making Mineral Amber, of which Paracelsus hath only writ in his *Book of Vexations of Philosophers*<sup>281</sup> and in the last edition of his work in the sixth<sup>282</sup> [book of] his Archidoxes; but because they cannot be made without the help of the Elixirs, therefore they deserve a place among the Elixirs, where I shall discover the virtue or rather the vice of making Amber.

**The Operation Of Making Pearls Consisteth  
Of These Parts. Viz:**

*Lac Virginis*  
Dissolved Pearls<sup>283</sup>  
Quicksilver and  
The White Elixir.

Take *Lac Virginis* or *Acetum acerrimum*, so much as you think sufficient for dissolving the Pearls, as in double proportion to the Pearls, as if there be three ounces of the Pearls let there be six ounces of *Lac Virginis*, wherein dissolve the Pearls and set the glass *in Balneo* to digest the space of a day. Then pour out the solution and distil it *in Balneo*, and in the bottom of the glass you shall find the thick oil of the Pearls, whereunto add so much of your white corporeal Elixir as sufficeth to make the matter like paste, and put thereto equal weight of the pearls of Quicksilver. If the matter be too thin, put more powder of the Elixir; if it be too thick, add more *Lac Virginis* or Quicksilver, till it be like liver. Grind this mass upon a stone till it be brought to a fit thickness.

Then make it up in what form you please, [and] therefore it is necessary that you have a pair of brass or iron moulds in readiness (but it would be better if they were of silver) of what form you will, and fill them with the matter while it is soft; then pierce them through with a needle or such like thing, and put as many of them in a glass as you will (but first hang them upon a thread) and close well the glass and bury it with the pearls therein two foot under the earth and let it stand there the space of six months till they be congealed with the cold into a shining and clear substance like natural Margarites. These Pearls made and compounded in this manner are no less than natural ones, but much greater and more excellent by reason of the white Elixir.

### The Operation Of The Magistry Of Carbuncles

Carbuncles have their birth and origin in the pits and golden mines of the earth, of the Spirit of Gold and mineral Salt, indurated and corporeal, being decocted and digested into the hardness of stone by the Archaeus<sup>284</sup> of Nature, as well by the heat of the climate as by the great heat of the Sun; for they arise from the Spirit of the *minere* of Sol or Gold under the earth, by whose influence they shine as also from [whom] the[y are] hardened into the nature of the stone; whence the philosopher intendeth and endeavoureth as he can to imitate nature by art and to make and compound artificial Carbuncles above the earth with the same materials which nature formeth them of under the earth; therefore he useth the same principles, operating with the Spirit and Soul of Sol undivided, and the most hard Salt of the earth, whereof Venice glass is made, which two are the material organs. For [the] manual [operation] three things are required, that is to say a glass maker furnace<sup>285</sup>, a flaming fire and a crucible.

We now come to the materials, which are two and are to be joined together; the first giveth the form, the other receiveth it. That which giveth the form is the Spirit and Soul of Sol or Gold, joined together in the Red Elixir and is the agent and, as it were, the man. That which receiveth the form is the hardest salt of the earth contained in glass, and is the power of heaven impregnating the earth; the patient is the power of the earth retaining the impression of the heaven.

Having thus demonstrated the theory we now lay the foundation[s] of the practice, which are two, whereof the first is the preparation of the Elixir, the other of glass. Therefore your red corporeal Elixir is to dissolved with the oil or tincture of Mars or Iron, because it has the greatest virtue above all other bodies, by whose celestial power the earth, that is to say the glass, is to be brought to the hardness of a stone and converted into stone. And so the Elixir is prepared for projection upon glass; but for the preparation of glass there is no more required but that it be made of the same matter that Venice glass is made of, the composition of which, if ye know not, take as much Venice glass as you please and weigh it exactly, upon which [to] project your Elixir. When you have done so, put your glass in the crucible to melt, and when it is well molten then take your corporeal red Elixir dissolved as before (or if you will, undissolved) as much as sufficeth to tinge the molten glass, and put it tied up in a paper in the glass, stirring it a little with a rod, and there let it stand the space of an hour. Then take out the crucible and pour the matter into an ingot, and it will be malleable but as hard as glass and stone-like to the sight; and you may either cut it like stone or work it with a hammer. This Carbuncle stone or metal hath the property of a Carbuncle in shining and glistening above all natural Carbuncles; and if you touch a Toad or Spider, they presently die, because it taketh virtue from the Elixir against all poisons. And if the sick carry this Carbuncle about with him, so that it doth touch the region of his heart, it taketh away the cardiac passion and diminisheth the strength of the disease.

**Of The Composition Of The Mineral Electrum Of<sup>286</sup> Amber As Well Natural  
As Artificial And Of The Bell Made Of Amber Used By Trithemius**

Having finished these two secrets we now come to the Electrum, but whether it is to be reckoned amongst stones or amongst bodies it may be doubted because in the West Indies it is found writ in Spanish Decads of the virtue thereof, for it is affirmed to be the greatest antidote against all poison and far more noble than Gold; but if it be a metal it must necessarily be the chief and supreme of all metals, for other metals have their origin from Sulphur and Mercury, but this metal consisteth of seven metals and is the best of all those which grow by the Ideas of the earth. For where Gold is taken for the most noble of all metals by reason of its perfect digestion and colour, this hath a greater degree of digestion and colour having a higher colour, that is to say, clear red, approaching nearer to the true colour of the Sun. For as Gold is the Sun of other metals, so this Electrum is to Gold as the heaven [is] to the Sun, wherein nature, as it were, in heaven hath created certain stars shining with clear beams of a silver colour, showing plain to the eye that it consisteth of red and white metals mixed in the highest degree of digestion.

On the contrary it may be objected:

Object 1. That there are only six metallic bodies, amongst which this is not to be found<sup>287</sup>, therefore it is a rather Spirit than a body.

Also that:

Object 2. The *minere* of every body or metal is converted into metal by fusion, but the *minere* of Electrum in melting always remaineth, therefore it is no metal.

Object 3. There is nothing generated in the earth but stones, Spirits, metals or mean minerals. But Electrum is none of these, therefore it seems to be no mineral.

1. To the first objection it is thus answered. We say that it is not apparent out of the books of any of the ancient philosophers that they even dreamed of this natural and mineral Electrum. But more to the purpose: those that are called Spirits which fly from the fire; but the Electrum flieth not from the fire; therefore it is no Spirit as Quicksilver and the rest and also mean minerals.

2. We now come to the next. We grant that the *minere* of every metal is converted into metal by the fire, which consists of Mercury and Sulphur. This axiom is evident in those metals which are imperfect and fly from the fire either in their *minere* or in themselves after they be reduced to metal; and also the Gold *minere*, although before melting it fly from the fire, before the Gold be molten, but is fixed in all probation, therefore it is accounted the worthiest of all metals which consist of Sulphur and Mercury.

3. Now the third. I say that I think it rather is of a stony and metallic nature joined together, by which mixture it differs from a stone and also from a metal; but because it consisteth of Mercury, earthly Salt and Sulphur mixed, therefore it gets unto it a mixed nature of them, so that it is half stone, half metal<sup>288</sup>.

Wherefore it is to be judged that it consisteth of three natures mixed together; that is to say mineral, metallic and stony, and is the best of all those which grow in the Ideas of the earth, for it exceeds mean minerals in fixation and constancy, because they pass away in fume by long melting and vanish to nothing, or else they melt easily in moisture as Salts etc. But this Electrum or<sup>289</sup> Amber remaineth fixed and constant as well in the fire as water.

It exceeds metals in digestion, colour and dignity. In digestion because it is endowed with the sign of greater and more perfect digestion. For as gold is more yellow by reason of his greater heat and more perfect digestion, so the Electrum, because it hath a higher colour than Gold hath, therefore it is more digested in colour; for as Gold exceeds other metals in colour, so Electrum exceeds Gold; for Gold is yellow but Electrum is red, which is a higher colour than yellow. And as Silver is the Luna of white metals, so Gold is the Sol of red metals: so Electrum is to Gold as the heaven is to Sol in dignity and value. For by how much more Gold is more noble than Silver, so much this Electrum is more noble than Gold.

Lastly it exceeds stones in shining and virtue; in shining because these shine by reason of their hardness; so this Electrum showeth many sparks<sup>290</sup>, not by reason of its hardness, but by reason of this completeness. And as the heaven is adorned with stars, so this Electrum [is] with sparkling, because it hath the clearness and brightness of all metals. And as the heaven containeth all the stars and planets, so this Electrum, which is the heaven of metals, containeth the Sun and Moon and the rest of the planets in itself, Gold and Silver as it were the greater luminaries, the other bodies or metals as the rest of the planets, mean minerals as stars in virtue.

For although many stones have singular properties and virtues, so that some help the sight, others the spleen, some the heart, some stop blood, some hinder abortiveness, some hasten childbirth, some resist poison, yet there is no one found which takes away all infirmities, as Electrum does more than all mean minerals, metals or<sup>291</sup> stones, according to the three-fold conjunction, that is to mineral, metallic and lapifidic<sup>292</sup>.

Therefore, whatsoever others please to think of this natural Electrum, this seemeth most probable to me, that it is not simply a metal, but of a nature exceeding metal; for whereas stones, mean minerals and metals are generated of Salt, Sulphur and Mercury, this Electrum takes his original from stones, minerals and metals. From stones it takes Salt, from minerals Mercury and from Metals Sulphur<sup>293</sup>. These three being brought into one by the Ideas of Nature are

its elements, from a greater virtue and power of nature; which elements have formed a higher degree of perfection than in any other stone, mineral or metal, as it were by the command of God, nature should ascribe a crown of virtue and dignity above all minerals.

But however it be, it is taken two manner of ways among the later Magicians [and] Rosie Crucians, and that is to say, that which is made naturally and [that which is made] artificially. Naturally is that which groweth in the natural Ideas of the earth; the artificial is that which is made by art above the earth in imitation of nature.

Whence Paracelsus, a worthy Master in Magic, seeing fully the nature and the utility of Alchemy, commanding to make the Elixir thereof, when as its natural body cannot anywhere be had, in his *Book of the Vexations of Philosophers*<sup>294</sup> and the sixth of his *Magical Archidoxes*<sup>295</sup>, teacheth to compound an Artificial Electrum that the Elixir must be made thereof, as appears more at large in the said books, which I like not at all. He teacheth how to make the Elixir out of Electrum; I contrarily, the Electrum out of Elixir; he would make the Elixir out of the virtue of the Elixir. I leave his way to his own followers, but I desire mine not to weary and vex themselves in such a weak, but [in] a more strong principle.

I make two kinds of Electrum one way, the first whereof is spiritual, the other corporeal. First of the former. After you have made your red corporeal Elixir by projection, in the same crucible melt one ounce of Lead and likewise another of Tin; and when they are hot, take the crucible from the fire and pass therein one ounce of Silver melted in another crucible. And when these three white metals begin to be cold, take two ounces of Mercury well purged and put these two ounces of Quicksilver upon the molten metal by drops, then increase the fire gently so that too much of the Mercury do not fume away<sup>296</sup>. Then in three other several crucibles melt Iron, Copper and Gold, of each one ounce, which you must have in readiness molten. And first put your molten Gold into the crucible where your four white metals stand molten, and pour upon them<sup>297</sup> the Copper and last of all your Iron, stirring the whole mass with a stick, that is may mix together, and let it stand in a melting heat the space of an hour. Then take all out that it may mix together and let it stand in melting in the crucible and consider well the weight of it and according to the goodness of the Elixir make projection for Medicine. And then you have created and compounded spiritual Electrum of the weight of seven ounces, consisting of seven metals, which metals so converted into Medicine, will be the Elixir of Electrum and an universal Medicine, for you need not after regard upon what body (or metal) you project it. It is also the choicest of Medicine for man's body; for although three or four of all the diseases of the Microcosm were united together, yet they may be cured with this one Medicine. If you dissolve part of this in Spirit of Wine and distil away the same Spirit *in Balneo* and the oil of the Medicine of Elixir<sup>298</sup> remain in the bottom, you shall have a most noble Rosie Crucian Medicine of Life.

Note that if your Iron melt not well, then dissolve your Electrum in the oil or tincture of Mars, dissolving and congealing until it have imbibed a sufficient quantity.

But if you desire to make corporeal Electrum, when your Medicine beginneth to fail to convert metals any more into Medicine, then in like manner project your Medicine upon your melted metals or bodies and they will be converted into corporeal Electrum, metallic and malleable. Of the abuse of this Electrum Paracelsus writeth that Virgil Hispanus<sup>299</sup> and Trithemius made a diabolical bell of this Artificial Electrum, upon which, when they would invoke Spirits (which they called by a more decent name of Intelligences) they writ the character of what Spirit they desired and at the third ring of the bell the Spirits obeyed their desires so long as they desired to talk with them; and when they would talk no more, they hid the character, and by the reverse ringing of the bell the Spirits departed. This supernatural Magic is altogether infamous and unlawful<sup>300</sup>.

Before I come to the *Particularia*, or the preparations of the seven metals, I will discover some Arcanums belonging to Vitriol, Sulphur and [the] Magnet.

There is a subterranean mineral Salt called Vitriol, which for dyeing of cloths and many other uses we cannot want. It is distinguished from other Salts in its sharpness and quality in eating through. The mineral of this Salt is strange [and] of a very hot and fiery quality as [is] apparent in its Spirit, the like [of which is] not found in other Salts. It is white and red and hath an extraordinary medicinal quality. This Salt containeth a combustible Sulphur, which is not in other Salts. Therefore in metalline affairs, touching their transmutation, it performeth more than others. It not only opens some, but helpeth the generation of others by reason of its innate heat. When Vitriol is separated by fire, then its Spirit at first comes in a white form; after that there comes from its earth a Spirit of a red condition. Staying in the earth, the Salt, being united with its expelled Mercury and Sulphur, can sharpen them; the remainder that stayeth behind is a dead earth of no efficacy. Consider well this now kindled Ternary, for as you find in Vitriol's body three distinct things, as Spirit<sup>301</sup>, Oil<sup>302</sup> and Salt, even so you may expect from its own Spirit again (which without the mingling of its oil is driven from its matter) three distinct things as you did formerly from the body of Vitriol, which well deserveth the name of *Speculum Sapientiae Physicae*. Separate this Spirit of Vitriol as it ought, then that affords again unto you three principles, out of which only, without any addition, since the beginning of the world the Philosophers' Stone hath been made. From that you have to expect again a Spirit of a white form, an oil of a red quality [and] after these two a crystalline Salt. These three being duly joined in their perfection generate no less than the Philosophers' great Stone, for that white Spirit is merely Philosophers' Mercury and the red oil is the Soul<sup>303</sup> and the Salt is the true Magnetic Body. As from the Spirit of Vitriol is brought to light the red and white tinctures, so from its oil there is made Venus, her tincture, and in the centre they are much distinct assunder, though they dwell in one body. In this knowledge lieth hid an irrecoverable error;

worldly wit cannot conceive of it that the Spirit of Vitriol and the remaining oil should be of so great distinction in their virtue. Touching their properties, the Spirit being well dissolved and brought into its three principles, Gold and Silver only can be made of it, and out of its oil only Copper, which will be apparent in a proof made.

The condition of the Spirit of Vitriol and its remaining oil is this, that where there is Copper and Iron, the Solar Seed is not far from it commonly; and again where there is Seed of Gold at hand, Copper and Iron are not far from it, by reason of its attractive magnetic quality and love, which they, as tingeing Spirits in a visible manner continually bear one to another. Therefore Venus and Mars are penetrated and tinged with the superabounding tincture of Gold, and in them there is found much more the root of the red tincture than in Gold itself, unto which there belongeth also the *minera* of Vitriol, which goeth beyond these in many degrees, because its Spirit is mere Gold and *rubedo*<sup>304</sup>, a crude, indigested tincture, and in very truth is not found out otherwise.

But this Spirit must be divided into certain distinct parts, as into Spirit, Soul and Body. The Spirit is the Philosophic Water, which, though visibly parted assunder, yet can never be separated radically (because of their unavoidable affinity they bear and have one to another) as it appeareth plainly when afterward they are joined, [for] the one, in their mixture, embraceth the other, even as a magnet draweth Iron, but in a meliorated essence better than they had before their dissolution. This Spirit (I can prove) is the essence of Vitriol, because this Spirit and oil do differ so much and were never united radically; [and] because the oil cometh after the Spirit, each can be received apart. This fiery Spirit may rather and more fitly be called an<sup>305</sup> essence, Sulphur and substance of Gold, and it is so, though it lieth lurking in Vitriol as a Spirit.

This golden Water, or Spirit drawn from Vitriol;, contains again a Sulphur and a Magnet; its Sulphur is the *anima*, an incombustible fire; the Magnet is its own Salt, which in the conjunction attracteth its Sulphur and Mercury, uniteth with the same and are inseparable companions. First in a gentle heat is dissolved the undigested Mercurial Spirit; by this is further extracted after a magnetic way by the Mercurial Spirit<sup>306</sup>; so still the one is a Magnet unto the other, bearing magnetic love one to another, as such things whether the last together with the medium is drawn forth by the first, and are thereby generated and thus take their beginning. In this separation and dissolution the Spirit or Mercury is the first Magnet, showing its magnetic virtue towards the Sulphur and Soul which it, *quasi magnes*, attracteth. This Spirit, *per modum distillationis*, being absolved and freed, showeth again its magnetic power towards the Salt, which it attracteth from the dead earth; after the Spirit is separated from it, then the Salt appeareth in its purity. If that process be further followed, and after a true order and measure the conjunction be undertaken and the Spirit and Salt be set together into the philosophic furnace, then it appears again how the heavenly Spirit striveth in a magnetic way to attract its own Salt, [for] it dissolveth the same within forty days,

bringeth it to an uniform water with itself, even as the Salt hath been before its coagulation. In that destruction and dissolution appeareth the highest blackness and eclipse and darkness of the earth that was ever seen. But in the exchange thereof a bright, glittering whiteness appearing, then the case is altered and the dissolved, fluid, waterish Salt turns into a Magnet; for in that dissolution it layeth hold on its own Spirit, which is the Spirit of Mercury, attracteth the same powerfully like a Magnet, hiding it under a form of a dry, clear body, bringing the same by way of uniting into a deep coagulation and firm fixedness by means of a continued fire and the certain degrees thereof.

Note that from all metals, especially from Mars and Venus, which are very hard and almost fixed metals, of each part can be made Vitriol. This is the reduction of a metal into its mineral. For minerals grow to metals and metals were at first minerals, and so minerals are *proxima materia* of metals, but not *prima*. From these Vitriols may be made other reductions, namely a Spirit is drawn from them by the virtue of the fire.

This Spirit being driven over, then there is again a reduction of a mineral into its spiritual essence, and each Spirit in its reduction keepeth a metalline property; but this Spirit is not the *prima materia*.

#### **Of The Sulphur And Ferment Of The Philosophers**

I have formerly told you plainly how the Philosophers' Sulphur is made; [in] *loco masculi* pour this Spirit upon purged and fined Gold. Let it dissolve and putrefy fourteen days, *in Balneo Mariae* distil it and pour the water again on the Gold calx, and cohobate this until the Gold pours over with the water; set this again to distil, abstract the water gently, leave a third part of it in the bottom, then set it into a cellar; let it coagulate and crystallise, wash these crystals with distilled water, amalgamate them with Mercury vive, evaporate the Mercury gently, then you have a subtile powder; put it in a glass, lute it, reverberate it for three days and nights, do[ing] it gently; thus is the philosophers' Sulphur well prepared for your work and this is the Purple Mantle or Philosophic Gold; keep it safe in a glass for your conjunction.

#### **Of The Philosophic Vitriol**

After the philosophers' Sulphur is made, which [in] *loco masculi* is to make the King or man, now you must have the female or wife, which is the Mercury of the Philosophers or the *materia prima lapidis*, which must be made artificially; for our Azoth is not common Vinegar, but is extracted with the common Azoth, and there is a Salt made of *materia prima* or Mercury of the Philosophers, which is coagulated in the belly of the earth. When this matter is brought to light it is not clear and it is found everywhere; it is ponderous and hath a scent of a dead body. Take this matter, distil, calcine, sublime [and] reduce it to ashes, for if an artist want ashes, how can he make a Salt, and he that hath not a metalline Salt, how can he make the philosophers' Mercury?

Therefore if you have calcined the matter, then extract its Salt, rectify it well, let it shoot into the Vitriol, which must be sweet without any corrosiveness or sharpness of Salt. Then you get the philosophers' Vitriol or Philosophic Oil. Make further of it a mercurial water. Thus you have performed an artificial work. This is called the philosophers' Azoth, which purgeth Laton<sup>307</sup> that<sup>308</sup> is not yet washed. For Azoth washeth Laton, as the ancient philosophers have told two or three thousand years agone. For the philosophical Salt or Laton must with its own humidity, or its own mercurial water be purged, dissolved, distilled, attract its Magnet and stay with it. And this is the philosophers' Mercury or *Mercurius duplicatus*, and it consists of<sup>309</sup> two Spirits, or a Spirit and a water of the Salt of Metals. Then this water beareth the name of *Succus Lunaris*<sup>310</sup>, *Aqua Coelestis*, *Acetum Philosophorum*, *Aqua Sulphuris*, *Aqua Permanens*, *Aqua Benedicta*. Take eight or ten parts of this water and one part of the Ferment or Sulphur of Sol; set it in the philosophers' egg, lute it well; put it in the athanor, into that vaprous yet dry fire; govern it to the appearance of a black, white and red colour; then you get the Philosophers' Stone.

### Of The Philosophic Magnet

Hermes, the father of the philosophers, had this art and was the first that wrote of it and prepared the Stone out of Mercury, Sol and Luna of the philosophers, whom some hundred laborators have imitated. I do assure you for a truth that the philosophers' Stone is composed of two bodies; the beginning and ending of it must be with philosophic Mercury.

And this is now *prima materia* and is coagulated in the entrails of the earth, first into Mercury, then into Lead, then into Tin and Copper, then into Iron, etc. Thus the coagulated Mercury must by art be turned into its *prima materia* or water, that is mercurial water.

This is a stone and no stone<sup>311</sup>, of which is made a volatile fire in [the] form of a water, which drowneth and dissolveth its fixed father and its volatile mother. Metalline Salt is an imperfect body which turneth to philosophic Mercury, that is a permanent or blessed water, and is the philosophers' Magnet, which loveth its philosophic Mars, sucketh unto him and abideth with him. Thus our Sol hath a Magnet also, which Magnet is the first root and matter of our Stone. If you conceive of and understand my saying and what Hermes saith, three things are required for the work; first a volatile or mercurial water, *aqua coelestis*, then *Leo viridis*, which is the philosophic Lune, thirdly *oes Hermetis*, Sol or Ferment.

Lastly note philosophers had two ways, a wet one, which I made use of, and a dry one. Herein you must proceed philosophically; you must purge well the philosophers' Mercury and make Mercury with Mercury, adding the philosophic Salt, Ferment or Sulphur of philosophers and then you have [firstly] the philosophers' magnet, that is the philosophers' Mercury, secondly the metalline Salt or philosophic Salt, thirdly *oes Hermetis* or philosophic Sulphur.

### A Process Upon The Philosophic Work Of Vitriol<sup>312</sup>

Take ten pound of Vitriol dissolved in distilled rain water; being warmed let it stand for a day and a night. At that time many feces were settled. I filtered the matter, evaporated it gently *ad cuticulum usque*. I set it in a cool place to crystallise. This onshot<sup>313</sup> Vitriol I exiccated, dissolved it again in distilled rain water, let it shoot again, which work I iterated so till the Vitriol got a celestial green colour, having no more any feces about it, and lost all his corrosiveness and was of a very pleasant taste.

This highly putrefied Vitriol, thus crude and not calcined. I put into a coated retort, distilled it in open fire, drove it over in twelve hours space by an exact government of fire in a white fume. When no more of these fumes came and the red corrosive oil began to come, then I let the fire go out. The next morning, all being cold, I took off the receiver, poured the gift in the receiver into a body, and some of the lute being fallen in too, I filtered it and had a fair menstrual water, which had some phlegm because I took that Vitriol uncalcined, which I abstracted *in Balneo*, not leaving one drop.

I found my Chaos in the bottom of a dark redness, very ponderous, which I poured into a viol, sealed it *hermeticê*, set it on a three-foot into a wooden globe into a vaprous bath made of water, where I left it so long till all was dissolved. After some weeks it separated into two parts, into a bright, transparent water and into an earth, which settled to the bottom of the glass in [the form of] a thick, black corrosive like pitch.

I separated the white spirit from it and the fluid black matter I set in again to be dissolved. The white Spirit which was dissolved [out] of it I separated again. This work I reiterated, leaving nothing in the bottom save a dry, red earth. After that I purged my white Spirit *per distillationem* very exactly; it was as pure as the tear that falls from the eye. The remaining earth I exiccated under a muffle; it was porous and as dry as dust. On this I poured again my white Spirit [and] set it in a digestion. This Spirit extracted the Sulphur or philosophic Gold and was tinged of a red yellow. I canted it off from the matter and in a body I abstracted the Spirit from the Sulphur. That Sulphur stayed behind in [the] form of an oil, very fiery, nothing [being] like unto its heat, as red as Ruby. The<sup>314</sup> abstracted white Spirit I poured on the earth again, extracted further in Sulphur and put it to the former. After this that *corpus terrae* looked of a paler colour, which I calcined for some hours under a muffle [and] put it into a body; on it I poured my white Spirit [and] extracted its pure, white, fixed Salt. The remaining earth was very porous, [and] good for nothing, which I flung away; thus these three principles were fully and perfectly separated.

After this I took my astral, clarified Salt, which weighed half an ounce after the weight at Strasbourg in Germany, and of the white Spirit, which weighed four ounces, of Mercury one ounce and a quarter of an ounce. These I divided into two parts, whose quantity was half an ounce and one dram. I put this Salt to one

part of the other in a viol and nipped it [and] set it in digestion; there I saw perfectly how the Salt dissolved itself again in this Spirit, therefore I poured to it the other part, which was half an ounce and one dram. No sooner this was put to it than presently the body, together with the Spirit, turned as black as coal, ascended to the end of the glass, and having no room to go any further, it moved to and fro. Sometimes it settled to the bottom; by and by it rose to the middle; then it rose higher. Thus it moved from the fourth of July to the seventh of August, namely thirty-four days, which wonderful work I beheld with admiration. At last these were<sup>315</sup> united and turned to a black powder staying on the bottom and was dry. Seeing that it was so I increased my fire in one degree, took it out of the wet and set it in ashes; after ten days the matter on the bottom began to look somewhat white, at which I rejoiced heartily. This degree of fire I continued till the matter above and below became as white as the glittering snow. But it was not yet fix[ed] as I discovered upon] making trial of it, [so I] set it in again [and] increased my fire one degree higher; then the matter began to ascend and descend, moved on high, stayed in the middle of the glass, not touching the bottom of it. This lasted thirty-eight days and nights, [and] I beheld them as well as formerly, at the thirty days, a variety of colours which I am not able to express.

At last this powder fell to the bottom [and] became fix[ed]. [I] made projection with it, putting one grain of it to one and a quarter ounce of Mercury, transmuting the same into very good Lune. Now it was time to restore unto this white tincture her true *anima*, and imbibe it, to bring it from its whiteness unto redness and to its perfect virtue.

Thereupon I took the third principle, namely the *anima*, which hitherto I had reserved, (in quantity it was one ounce and one dram) poured it to my reserved Spirit of Mercury, (whose quantity was one ounce and a quarter of an ounce) [and] drew it over several times *per alembicum* so that they in the end united together. I then divided<sup>316</sup> them into seven equal parts; one part I poured on my clarified earth or tincture, which greedily embraced its *anima*, together with its Spirit, and turned to a ruddiness in twelve days and nights, but had no tingeing quality as yet, saving [that] Mercury vive and Saturn it transmuted into Lune, which Lune at the separating yielded three grains of Gold. I proceeded further with my imbibation and carried all the seven parts of the *anima* into [my tincture]; at the fourth imbibation one part of my work tinged ten parts of Copper into Gold; at the fifth imbibation one part tinged an hundred parts; at the sixth it tinged a thousand parts; at the seventh it tinged ten thousand parts. At this time I got of the true Medicine four ounces, half an ounce and one dram.

#### **Of The Preparation Of The Seven Metals. And First Of The Sulphur Of Sol, Whereby Luna Is Tinged Into Good Gold**

Take of pure Gold, which is three times cast through Antimony, and of well purged Mercury vive, being pressed through leather, six parts; make of it an *Amalgama*; to the quantity of this *Amalgama* grind twice as much of common Sulphur; let it evaporate on a broad pan in a gentle heat under a muffle, stirring it

well with an Iron hook; let the fire be modified that the matter do not melt together. This Gold calx must be brought to the colour of a Marigold flower, then it is right. Then take one part of Saltpeter, one part of Sal Armoniack, half a part of grinded pebbles<sup>317</sup> [and] draw a water from it. Note this water must be drawn warily and exactly; to draw it after the common way will not do; he that is used to chemic preparations knows what he hath to do. And note you must have a strong stone retort, which must be coated, to hold the Spirit closely; its upper part must have a pipe upward of half a span's length; its wideness must bear two fingers breadth; it must be set first in a distilling furnace, which must be open above that the upper pipe may stand out directly; apply a large receiver [and] lute it well; let your first fire be gentle, then increase it that the retort look glowing hot; put a spoonful of this ground matter in at the pipe suddenly with a wet clout [and] the Spirits come rushingly into the receiver. These Spirits being settled, then carry in another spoonful; in this manner you proceed till you have distilled all. At last give time to the Spirits to be settled [and] to turn into water. This water is a hellish, dissolving, strong one, which dissolveth instantly prepared Gold Calx and laminated Gold into a thick solution. This is that water which dissolves not only Gold but bringeth it to a volatility, carrying it over the helmet, whose *anima* may afterwards be drawn from its torn body.

Note the Spirit of common Salt effecteth the same if drawn in that manner which I shall mention afterwards. If three parts of this Salt Spirit be taken, and one part of *Spiritus Nitri*, it is stronger than Sal Armoniack water, and is better because it is not so corrosive, dissolveth Gold the sooner, carrieth it over the helmet, [and] maketh it volatile and fit to part with its Soul. You have your choice to use which you think best and may easier be prepared thus: Take one part of the prepared Gold calx and three parts of the water which you make choice of. Put it into a deep body, lute a helmet of it, set it in warm ashes [and] let it dissolve; that which is not dissolved, pour three times as much water upon, that all dissolve. Let it cool, separate the feces, put the solution into a body, lute a helmet to it [and] let it stand in a gentle heat day and night *in Balneo Marine*. If more feces be settled separate them, digest them again *in Balneo* nine days and nights, then abstract the water gently to a spissitude like unto an oil in the bottom. This abstracted water must be poured on that spissitude [and] this must be iterated again and often that it grow weary and weak; remember to lute well at all times. To the oleity on the bottom pour fresh water which was not yet used; digest day and night, firmly closed, then set it in a sand cupel [and] distil the water from it [till it be reduced] to a thickness; make the abstracted water warm, put it in a body, lute it, abstract it, iterate this work and make all the Gold come over the helmet.

Note, at the next drawing always the fire must have one degree more. The Gold being come over into the water, abstract the water gently from it in the Balney to the oleity [and] set the glass into a cool place; there will shoot transparent crystals; these are the Vitriol of Gold. Pour the water from it, distil it again unto an oleity [and] sat it by for shooting; more crystals will shoot; iterate it as long as any do shoot. Dissolve these crystals in distilled water, put to it of purged Mercury

three times as much, shake it about, many colours will appear, an *Amalgama* falls to the ground [and] the water cleareth up. Evaporate the *Amalgama* gently under a muffle, stirring it still with a wire; at last you get a purple coloured powder, scarlet like; it dissolveth in Vinegar into a blood redness. Extract its *anima* with prepared Spirit of Wine mixed with the Spirit of common Salt, entered together into a sweetness. This tincture of Sol is like a transparent Ruby, leaving a white body behind.

Note that without information you cannot attain unto the Spirit of Salt; if it be not sweet it hath no attractive power; to the attaining hereof observe these following manuals: Take good Spirit of Salt, dephlegmed exactly, driven forth in that manner as ye shall hear anon. Take one part of it, add half a part to it of the best Spirit of Wine, which must not have any phlegm, but be a mere Sulphur of Wine and must be prepared in that manner as I shall tell you anon. Lute a helmet to it, draw it over strongly, leave nothing behind. To the abstracted [part] put more Spirit of Wine, draw it over somewhat stronger than you did the first time, weigh it, put a third time more [Spirit of Wine] to it [and] draw it over again well luted; putrefy this for half a month, or so long as it be sweet, and it is done in Balney very gently. Thus the Spirit of Wine and Salt is prepared, loses<sup>318</sup> its corrosivity and is fit for extracting.

Take the Ruby-red prepared Gold powder, put of this prepared Spirit of Salt and Wine so much that it stand two fingers breadth over it, set it in a gentle heat [and] the Spirit will be red tinged; this Spirit must be canted off. Pour a new Spirit on that which remaineth on the bottom, set it luted into a gentle heat, let it be tinged deeply, then cant it off; this work must be iterated (till) that the body of Sol remain on the bottom like Calx vive, which keep, for therein sticketh more Salt of Gold, which is effectual in ways of Medicine, as shall be showed anon.

Those tinged Spirits put together, abstract them gently *in Balneo* [and] there will be left a red subtile powder in the bottom, which is the true tincture animated, or Sulphur of Gold. Dulcify it with distilled rain water [and] it will be very subtile, tender and fair. Take this extracted Sulphur of Sol as you were taught, and as much of the Sulphur of Mars, as you shall hear anon when I treat of Mars. Grind them together, put it in a pure glass, pour on it so much of Spirit of Mercury - let it stand over it two fingers breadth - that the matter may be dissolved; see to it that all dissolve into a Ruby-like Gold water, jointly drive it over, then it is one and were at first of one stem. Keep it well, that nothing of it evaporate; put it in separated Silver calx, being precipitated with pure Salt and afterwards well edulcorated and dried; fix it together in a fiery fixation that it sublime no more; then take it and melt it in a wind-oven; let it stream well; then you have united Bride and Bridegroom and brought them unto Gold of a high degree. Be thankful to God for it as long as you shall live.

I shall hereafter at large set forth how this extracted Soul of Sol may be made potable. I will now set forth how the white solar body shall further be anatomised,

and that by art its Mercury vive and its Salt may be obtained. The process of it is thus.

Take the white body of Sol, from which you have drawn its *anima*, reverberate it gently for half an hour, let it become corporeal, then pour on it well rectified honey-water, which is corrosive [and] extract its Salt in a gentle heat. It is done in ten days space. The Salt being all extracted, abstract the water from it *in Balneo*, edulcorate the Salt with iterated distillings with common distilled water, clarify it with Spirits of Wine, then you have *Sol auri*, of which you shall hear more in its due place [and] of the good qualities in hath by way of medicine upon man. On the remaining matter pour Spirit of Tartar, of which elsewhere because it belongeth unto medicinals. Digest these for a month's time, drive it through a glass retort into cold water, then you have quick Mercury of Sol; many strive to get it but in vain.

There is one mystery more in Nature, that the white solar body, having once lost its *anima*, may be tinged again and brought to be pure Gold, which mystery is revealed to very few. I shall briefly declare it, as also about the universal Stone of [the] Philosophers, how it resteth merely upon the white Spirit of Vitriol, and how that all three principles are found only in this Spirit and how you are to proceed in and to bring each into its certain state and order.

Take the philosophic Sulphur, which in order is the second principle and is extracted with the Spirit of Mercury; pour it on the white body of the King<sup>319</sup>, digest it for a month in a gentle Balny, then fix it in ashes and at last in sand, that the brown powder may appear; then melt it with a fluxing powder made of Saturn; then it will be malleable and fair Gold as it was formerly, in colour and virtue nothing defective. But note, the Salt must not be taken from the Solar body.

There may be prepared yet in another manner a transparent Vitriol from Gold in the following manner.

Take good *Aqua Regis* made with Sal Armoniack one pound, *id est* dissolve four ounces Sal Armoniack in *Aqua Fortis*, then you have a strong *Aqua Regis*. Distil and rectify it often over the helmet, let no feces remain behind; let all that ascends be transparent. Then take thinly beaten Gold rolls, cast formerly through Antimony, put them into a body, pour on it *Aqua Regis*, let it dissolve as much as it will or as you can dissolve in it. Having dissolved all the Gold, pour into it some oil of Tartar or Salt of Tartar dissolved in fountain water till it begins to hiss. Having done hissing, then pour in again of the oil. Do it so long till all the dissolved Gold fallen to the bottom and nothing more of it precipitate, and the *Aqua Regis* clear up. This being done, then cant off the *Aqua Regis* from the Gold calx, edulcorate it with common water eight, ten or twelve times. The Gold calx being well settled, cant off that water and dry the Gold calx in the air where the Sun doth not shine. Do it not over a fire, for as soon as it feeleth the least heat in kindleth and great damage is done, for it would fly away forcibly that no

man could stay it. This powder being ready also, then take strong Vinegar, pour it on, boil it continually, over [the fire] in a good quantity of Vinegar, still stirring it that it may not stick unto the bottom, for twenty-four hours together, then the fulminating quality is taken from it; be careful you do not endanger yourself; cant off the Vinegar, dulcify the powder, and dry it. This powder may be driven *per Alembicum* without any corrosive, blood-red, transparent and fair, which is strange and uniteth unwillingly with the Spirit of Wine and by means of coagulation may be brought to a solar body.

Do not speak much of it to the vulgar. If you receive any benefit by my plain and open information, keep these mysteries secret to thy dying day. I will impart unto thee this arcanum also and entrust thee on thy conscience with it.

Take good Spirit of Wine, being brought to the highest degree, let fall into it some drops of Spirit of Tartar; then take thy Gold powder, put to it three times as much of the best and subtilest common Flowers of Sulphur, grind these together, set it on a flat pan under a muffle, give to it a gentle fire, let the Gold powder be in a glowing heat, put it thus glowing into the Spirit of Wine, cant off the Spirit of Wine [and] dry the powder against a heat. It will be porous being dried. Then add to it again three parts of *Flores Sulphurii* let them evaporate under a muffle, Neal the remaining powder in a strong heat and put it in Spirit of Wine; iterate this work six times [and] at last this Gold powder will be so soft and porous as firm butter; dry it gently, because it melteth easily. Then take a coated body, which in its hinder part hath a pipe; lute a helmet to it, apply a receiver, set it freely in a strong capel; let your first fire be gentle, then increase it; let the body be almost in a glowing heat, then put in the softened, well dried Gold powder, being made warm, behind at the hollow pipe. Shoot it in nimbly. There come instantly red drops into the helmet. Keep the fire in this degree so long till nothing more ascendeth and no more drops fall into the receiver. Note, in the receiver there must be of the best Spirit of Wine into which the drops of Gold are to fall.

Then take this Spirit of Wine, into which the Gold drops did fall, put it in a pelican, seal it *hermeticé* [and] circulate it for a month; it turneth then to a blood red Stone, which melteth in the fire like wax. Beat it small, grind among it lunar calx [and] melt it. Then you find (as) much good Gold as the Gold powder and the spirit of wine together with the moiety of<sup>320</sup> the added lunar calx did weigh, but one moiety of the lunar calx is not tinged and<sup>321</sup> is as good as it was to be used. If you hit this rightly, then be thankful to God. If not, do not blame me; I could not make it plainer.

Now if you will make this Vitriol, then take the powder formerly made, boiled in Vinegar; pour on it good Spirit of common Salt, mingled with Saltpeter water and the Spirit of Salt of Nitre. This Saltpeter water is made as *Aqua Tartaris* is made, using<sup>322</sup> Saltpeter. Gold is dissolved in this water, which being done then abstract the water to a thickness [and] set in a cellar; then there shooteth a pure Vitriol of Sol. The water which stayeth with the Vitriol must be canted off, [then]

distil it again to a spissitude, set it in the cellar [and] more of the Vitriol will shoot. Iterate this work as long as the Vitriol shooteth. If you are minded to make the Philosophers' Stone out of solar Vitriol, as some fantastic men endeavour in that way, then be first acquainted and ask counsel of thy purse and prepare ten or twelve pounds of this Vitriol, then you may perform the work very well, and the Hungarian Vitriol and others digged out of the mines will permit thee to do it. You may extract from this Vitriol also its Sulphur and Salt with spirit of wine, which is all easy work.

### **The Particular Of Lune And Of The Extraction Of Its Sulphur And Salts**

Take of Calx vive and common Salt and<sup>323</sup>, Neal them together in a wind oven; then extract the Salt purely from the Calx with warm water; coagulate it again, put to it an equal quantity of new Calx, Neal it, extract the Salt from it, iterate it three times, then is the Salt prepared.

Then take the prepared Lunar Calx, stratify the Calx with prepared Salt in a glass viol, pour strong water on it, made of equal quantities of Vitriol and Saltpeter, abstract the *aqua fort* from it, iterate this three times<sup>324</sup>, at last drive it strongly, let the matter melt well in the glass, then take it forth [and] your Lune is transparent and blueish like an Ultramarine. Having brought Lune thus far, then pour on it strong distilled Vinegar [and] set it in a warm place, the Vinegar is tinged with a transparent blue, like a Sapphire and attracteth the tincture of Lune, being separated from the Salt [and] all which comes from Lune goeth again into the Vinegar, which must be done byedulcoration; then you will find the Sulphur of Lune fair and clear. Take one part of this Sulphur of Lune, one half part of the extracted Sulphur of Sol [and] six parts of the Spirit of Mercury; join all these in a body, lute it well [and] set it in a gentle heat in digestion; that liquor will turn to a red-brown colour, having all driven over the helmet, and nothing [will] stand in the bottom; then pour it on the water<sup>325</sup> remaining of the Silver you drew your Sulphur from, lute it well, set it in ashes for to coagulate and to fix it eleven days and nights, or when you see the lunar body be quite dry, brown and nothing of it doth any more rise or fume; then it will melt quickly with a sudden flux [at the] fire before the blast; cast it forth; then you [will have] transmuted<sup>326</sup> the whole substance of Silver into the best, most malleable Gold.

I formerly told you that the Spirit of Salt can destroy Lune, so that a potable Lune can be made of it, of which potable Lune shall hereafter be set forth as to the preparation and the use thereof in medicine.

When you perceive that the Sulphur of Lune is wholly extracted and the Vinegar take no more tincture from her nor the Vinegar doth taste any more of Salt, then dry the remaining calx of Silver, put it into a glass, pour on it corrosive Honey water as you did to the Gold<sup>327</sup>, yet it must be clear and without any feces; set it in warmth for four or five days, extract Lune's Salt, which you may perceive when the water groweth white. The Salt being all out of it, then abstract the Honey

water, edulcorate the corrosiveness by distilling and clarify the Salt with Spirit of Wine. The remaining matter must be edulcorated and dried; pour upon it the Spirit of Tartar, digest it for half a month, then proceed as you did with the Gold. Then you have Mercury of Lune. The said Sal<sup>328</sup> of Lune hath excellent virtues upon man's body. The efficacy of its Salt and Sulphur may be learned by the following process.

Take of the sky-coloured Sulphur, which you extracted from Lune and is rectified with Spirit of Wine, put it in a glass, pour on it twice as much of Spirit of Mercury, which is made of the white Spirit of Vitriol. In like manner take of the extracted and clarified Salt of Silver, put to it three times as much of Spirit of Mercury. Lute well both glasses [and] set them in a gentle Balney for eight days and nights. Look to it that the Sulphur and Salt lose nothing, but keep their quantity as they were driven out of the Silver. Having stood these eight days and nights, then put them together into a glass, seal it *Hermeticê*, set it in gentle ashes, let all be dissolved and let it be brought again into a clear and white coagulation. At last fix them by the degrees of fire, then the matter will be as white as snow. Thus you have the white tincture, which with the volatile dissolved *anima* of Sol you may animate, fix, bring to the deepest redness and at last ferment and augment the same *ad infinitum*, the Spirit of Mercury being added thereunto. And note that upon Gold a process is to be ordered with its Sulphur and Salt.

If you understood how their *primum mobile*<sup>329</sup> is to be known, then is it needless in this manner and to that purpose to destroy metals; but you may prepare everything from or of the first essence and bring them to their full perfection.

#### **Of The Particulars Of Mars Together With The Extraction Of Its Anima And Salt**

Take of red Vitriol oil or oil of Sulphur one part and two parts of ordinary well water. Put these together [and] dissolve therein filings of Steel. This dissolution must be filtered. Being warmed, let it gently evaporate a third part of it, then set the glass in a cool place [and] there will shoot crystals as sweet as sugar, which is the true Vitriol of Mars. Cant off that water, let it evaporate more, set it again in a cold place [and] more crystals will shoot. Neal them gently under a muffle, stirring it still with an Iron wire; then you get a fair, purple coloured powder. On this powder cast distilled Vinegar, extract the *anima* of Mars in a gentle Balney, abstract again the Vinegar and dulcorate the *anima*. This is the *anima* of Mars, which, being added to the Spirit of Mercury and united with the *anima* of Sol, tingeth Lune into Sol as you heard about the Gold.

#### **Of The Particular Of Venus What Mysteries There Are Hid Therein And Of The Extraction Of Its Sulphur And Salt**

Take as much of Venus as you will and make Vitriol of it, after the usual and common practice; or take good Verdigris sold in shops - it effecteth the same; grind it very small, pour on it good distilled Vinegar [and] set it in a warmth; the

Vinegar will be [coloured a] transparent green, cant it off [and] pour on the remaining matter on the bottom new Vinegar; iterate this work as long as the Vinegar taketh out any tincture and the matter of the Verdigris on the bottom lieth very black. Put the tinged Vinegar together, distil the Vinegar from it to a dryness, else a black Vitriol will shoot, thus you get a purified Verdigris. Grind it small, pour on it the juice of immature grapes [and] let it stand in a gentle heat; this juice maketh the transparent tincture as green as a Smaragd and attracteth the red tincture of Venus, which affords an excellent colour for painters, limners and others for their several uses.

When the juice extracts no more of the tincture, then put all the extraction together, abstract a moiety of this juice gently, set it into a cool place [and] there shooteth a very fair Vitriol. If you have enough of that, then you have matter enough to reduce the same and to make of it the Philosophers' Stone, in case you should make a doubt to perform this great mystery by any other Vitriol. The common Azoth is not the matter of our Stone, but our Azoth or *materia prima* is extracted with the common Azoth and with the wine, which is the outpressed juice of unripe grapes, and with other waters also must be prepared. These are the waters wherewith the body of Venus must be broken and be made into Vitriol, which you must observe very well, then you may free yourselves from many troubles and perplexities.

But especially note that it may be done with great profit if you drive forth the red oil of Vitriol and dissolve Mars in it and crystallise the solution as you were told when I treated of Mars. For in this dissolution and coagulation Venus and Mars are united. This Vitriol must be nealed under a muffle unto a pure red powder and must be extracted further with distilled Vinegar as long as there is any redness in it.

Then you get the *anima* of Mars and Venus doubled. Of<sup>330</sup> this doubled virtue, after the addition of the *anima* of Sol, which you made in the before quoted quantity, take twice as much of Silver Calx and fix it. But note that there must be twice as much of the Spirit of Mercury than there was allowed in that place but in the rest the process is alike. The Salt of Venus must be extracted when the juice taketh no more of the green tincture; then take the remaining matter, dry it, pour Honey Water upon it, then that Salt goeth in that heat for five or six days and clarify it with Spirit of Wine; then is the Salt ready for your Medicine.

#### **Of The Particular Of Saturn Together With The Extraction Of Its Soul And Salt**

Saturn, the highest of the Celestial Planets, hath the meanest authority in our Magistry, yet is the chiefest key in the whole art. Saturn is not to be slighted by reason of its external despicable form; if he be wrought in a due process after the philosophers' way, he is able to requite all the labourer's pains bestowed upon him, for the great virtues of it in Medicine for man's health and for meliorating of metals<sup>331</sup>. The preparation of it is thus:

Take red Minium or Ceruse, laminate it thinly, hang these lamens in a large glass filled with strong Vinegar, in which is dissolved a like quantity of the best Sal armoniack, sublimed thrice with common Salt. Stop the glass' mouth very closely that nothing evaporate, set the glass in ashes in a gentle heat, otherwise the Spirits of the Vinegar and Sal armoniack ascend and touch the Saturnal lamens. At the tenth or twelfth day you will spy a subtile Ceruse hanging on those lamens; brush them off with a hare's foot [and] go on and get enough of this Cerus. Take a quantity of it [and] put it in a body; pour strong Vinegar on it, which several times hath been rectified and was fortified at the last rectification with a sixteenth part of Spirit of vulgar Salt, dephlegmed and drawn over. Spot the body well, or, which is better, lute a blind head to it, set the body in ashes to be digested, swing it often about and in a few days the Vinegar begins to look yellow and sweet at the first. Iterate three times<sup>332</sup>, it is sufficient.

The remnant of the Ceruse stayeth in the body's bottom, unshapely; filter the tinged Vinegar clearly, that is of a transparent yellowness, put all the tinged Vinegar together, abstract two parts of it *in Balneo Mariae*, [but] let the third part stay behind. This third part is of a reasonable *rubedo*. Set the glass in cold water, then the crystals will shoot off the sooner; being shot, take them out with a wooden spoon [and] lay them on a paper for to dry; these are as sweet as sugar and are of great energy against inflamed symptoms. Abstract the Vinegar further *in Balneo*, in which the crystals did shoot, set the distillation aside for the shooting of more crystals and proceed with these as you did formerly.

Now take all these crystals together; they in their appearance are like unto clarified sugar or Saltpeter; beat them in a mortar of glass or Iron, or grind them on a marble unto unpalpableness, reverberate it in a gentle heat to a bloodlike redness. Provided<sup>333</sup> they do not turn to blackness. Having them in a scarlet colour, put [them] in a glass, pour on them a good Spirit of Juniper abstracted from its oil and rectified several time into a fair, white, bright manner; lute the glass above, set it in a gentle heat [and] let the Spirit of Juniper be tinged with a transparent redness like blood; then cant it off neatly from the feces into a pure glass, with that proviso that no impure thing run therewith; on the feces pour over the Spirit of Juniper [and] extract still as long as any Spirit taketh the tincture. Keep the feces; they contain the Salt.

Take all these tinged Spirits together, filter them, abstract them gently *in Balneo* [and] there remaineth in the bottom a neat Carnation powder, which is the *anima* of Saturn. Pour on it rain water, often distilled; distil it strongly several times to get off that which stayed with the Spirit of Juniper, and so this subtile powder will be edulcorated delicately. Keep it in a strong boiling, cant it off, then let it go off neatly. Let it dry gently; for safety's sake reverberate it again gently for its better exiccation; let all impurity evaporate, let it grow cold, put it in a viol, put twice as much of Spirit of Mercury to it, seal it *hermeticé*; set it in a vaporous bath called the philosophers' *firmus equinus*, let it stand in the mystical furnace for a month,

then the *anima* of Saturn closeth daily with the Spirit of Mercury and both become inseparable, making up a fair, transparent, deeply tinged, red oil. Look to the government of the fire; be not too high with it, else you put the Spirit of Mercury as a volatile Spirit to betake himself to his wings, forcing him to the breaking of the glass. But if these be well united, then no such fear look for, for one nature embraceth and holdeth up the other.

Then take this oil or dissolved *anima* of Saturn out of the viol. It is of a gallant fragrancy. Put it into a body, apply a helmet to it, lute it well, drive it over, then Soul and Spirit are united together and fit to transmute Mercury precipitated into Sol.

The precipitation of Mercury is done thus: Take one part of the Spirit of Salt Nitre and three parts of oil of Vitriol; put these together, cast into half a part of quick Mercury, being very well purged, set it in sand, put a reasonable strong fire to it, so that the Spirits may not fly away [and] let it stand a whole day and night; then abstract all this Spirit, then you find in the bottom a precipitated Mercury, somewhat red. Pour the Spirit on it again, let it stand day and night, abstract it again and then your precipitate is at the highest *rubedo*; dulcify it with distilled water [and] let it strongly be exiccated. Then take two parts of this precipitated Mercury, one part of the dissolved Saturnal oil, put these together, set it in ashes [and] let all be fixed; not one drop must stick anywhere to the glass. Then it must be melted with due additional of Lead; they close together and afford Gold, which afterward, at the casting through Antimony, may be exalted.

Note that Mercury must not be precipitated unless with pure oil of Vitriol or oil of Venus, with the addition of the Spirit of Salt Nitre. Albeit such Mercury cannot be brought to its highest fixation by way of precipitating but its fixed coagulation is found in Saturn.

Beat the above said Mercury small, grind it on a stone, put it in a viol, pour on it the Saturnal dissolved oil [and] it entereth instantly, if so be you proceeded aright in the precipitation. Seal the viol *hermeticé*, fix it in ashes [and] at (the) last in sand, to its highest fixation. Then you have bound Mercury with a true knot and brought him into a fix[ed] coagulation, which brought its form and substance into a melioration with an abundance of riches. If you carry it on a white precipitate, then you get only Silver, which holds but little Gold.

One thing more I must tell thee about this process, that there is yet a better way to deal upon Saturn with more profit. Take two parts of the above said dissolved oil, or oil of the Saturnal Soul, one part of *Astrum Solis* and of Antimonial Sulphur, whose preparation followeth afterwards, two parts, half as much of Salt of Mars as all those are, weigh them together, put them into a glass viol and let the third part of it be empty; set them in together to be fixed, then the Salt of Mars openeth in this compound, is fermented by it and the matter begins to incline to blackness. For ten or twelve days it is eclipsed, then the Salt returns to its coagulation, laying hold in its operation on the whole compound. Coagulate it first

into a deep brown mass, let it stand thus unstirred in a continual heat [and] it turneth to a blood-red body? increase the fire that you may see the *Astrum Solis* to be predominant, which appeareth in a greenish colour, like unto a Rainbow; keep this fire continually, let all these colours vanish [and] it turneth to a transparent red stone, very ponderous, needless to be projected upon Mercury, but [which] tingeth after its perfection and fixation all white metals into the purest Gold. Then take of the prepared, fixed, red Stone or of the powder, one part and four parts of the white metal. First let the metal melt half an hour and let it be well clarified; then project the powder upon it [and] let it drive well so that it be entered into the metal and the metal begin to congeal; then is it transmuted into Gold. Beat the pot in pieces [and] take it out; if it hath any slacks<sup>334</sup> drive them with Saturn, then it is pure and malleable. If you carry it on Lune, then put more of the powder on it than you do upon Jupiter and Saturn, as half an ounce of the powder tingeth five ounces of Lune into Sol. Let this be a miracle. Fool not thy Soul with imparting this mystery unto others that are unworthy of it. Proceed with Salt of Saturn as you were informed about Mars and Venus, only [note that] distilled Vinegar performeth that which Honey Water did by the others and clarify it with Spirit of Wine.

#### **Of The Particular Of Jupiter With The Extraction Of Its Anima And Salt**

Take pumice stones sold in shops, neal them, quench them in old good wine, neal them again and quench them as you did formerly [and] let this nealing be iterated a third time; the stronger the wine is you quench withal, the better it is. After that dry them gently; thus are they prepared for that purpose. Pulverise these pumice stones subtilly, then take good Tin, laminate it, stratify it in a cementing way, in a reverberating furnace reverberate this matter for five days and nights in a flaming fire [till] it draweth the tincture of the metal. Then grind it small, first scraping the Tin lamens; put it in a glass body, pour on it good distilled Vinegar and set it in digestion [when] the Vinegar draweth the tincture, which is red-yellow. Abstract the Vinegar *in Balneo*, edulcorate the *anima* of Jupiter with distilled water, exccate gently and proceed in the rest as you did with the *anima* of Saturn, viz., dissolve radically in or with the Spirit of Mercury, drive them over, pour that upon two parts of red Mercury precipitated; being precipitated with this Venerean, sanguine quality, then coagulate and fix; if done successfully you may acknowledge Jupiter's bounty that gave leave to transmute this precipitate into Gold, which will be apparent at their melting. It performeth this also, it transmuteth ten parts of Lune into Gold, if other Sulphurs be added thereunto; force no more upon Jupiter, it is all he is able to do; being of a peaceable disposition he told all what he could do.

The process about this Salt is to extract it with distilled rain water, clarified with Spirit of Wine.

### **Of The Particular Of Mercury Vive And Of Its Sulphur And Salt**

Take of quick Mercury, sublimed several times, half a pound<sup>335</sup>, grind it very small, pour on it a good quantity of sharp Vinegar, boil it on the fire for an hour or upward, stirring the matter with a wooden spatula, [then] take it from the fire and let it be cold, [when] the Mercury settleth to the bottom and the Vinegar cleareth up. If it be slow in the clearing, let some drops of Spirit of Vitriol fall into the Vinegar; it doth precipitate the other, for Vitriol precipitateth Mercury Vive, Salt of Tartar precipitateth Sol, Venus and common Salt doth precipitate Lune and Mars does the like to Venus; a lixivium<sup>336</sup> of Beech ashes doth it to Vitriol and Vinegar is for common Sulphur, and Mars for Tartar and Saltpeter for Antimony. Cant off the Vinegar from the precipitate [and] you will find the Mercury like a pure washed sand. Pour on it Vinegar, iterate this work a third time, then edulcorate the matter [and] let it dry gently.

Take two ounces of *anima* of Mars, one ounce of *anima* of Saturn, one ounce of *anima* of Jupiter, dissolve these in six ounces of Mercurial Spirit [and] let all be dissolved; then drive it over, leaving nothing behind [and] it will be a golden water like a transparent dissolution of Sol; your prepared and edulcorated Mercury must be warmed in a strong viol, pass this warmed water gently upon [the other]<sup>337</sup>, a hissing<sup>338</sup> will be, stop the viol and then the hissing<sup>338</sup> is gone; then seal it *hermeticé*, set it in a gentle Balney [and] in ten days the Mercury is dissolved into a grass-green oil. Set the viol in ashes for a day and a night [and] rule the fire gently; this green colour [then] turneth into a yellow oil; in this colour is hid the *rubedo*; keep it in this fire and let the matter turn to a yellow powder like unto Orpiment; when no more comes over, then set the glass in sand for a day and a night; give a strong fire to it, let the fairest ruby *rubedo* appear, melt it to a fixedness with a fluxing powder made of Saturn [and] it comes now to a malleableness; one pound of it containeth two ounces of good Gold, as deep as ever Nature produced any.

### **An Oil Made Of Mercury And Its Salt**

Take quick Mercury, often sublimed and rectified with Calx Vive, put it in a body, dissolve it in a heat in strong nitrous water, [and] abstract the water from it; the corrosiveness which stayeth there must be extracted with good Vinegar well boiled in it. At last abstract the Vinegar, [when] the remainder of it must be dulcified with distilled water and then exiccated. Afterward on each pound must be poured one pound of the best Spirit of Wine. Let it stand luted in putrefaction, then drive over what may be driven, first gently, then more strongly. From that which is come over abstract the Spirit of Wine *per Balneum* [and] there stayeth behind a fragrant<sup>339</sup> oil, which is *Astrum Mercurij*, an excellent remedy against venereal diseases.

Seeing the Salt and *Astrum* of Mercury is of the same medicinal operation, I hold it needful to write of each in particular and will join their operation into one and

declare of it in the last part about the Salt of Mercury, because they are of one effect in medicinal operations. Take the made oil or *Astrum Mercuri*, which by reason of its great heat keeps its own body in a perpetual running, casting it on the next standing earth, from which you formerly drew the oil; set it in a low heat [and] and the oil draweth its own Salt. That being done, put to it a reasonable quantity of Spirit of Wine [and] abstract it again; the Salt stayeth behind, dissolved in the fresh Spirit of Wine, being dulcified by cohobation. Then is the Mercurial Salt ready and prepared for the Medicine. Mercury is able to do no more, neither *particulariter* nor *universaliter*, because he is far off from philosophers' Mercury, although many are deceived in their fancies to the contrary.

### **Of The Particular Of Antimony Together With The Extraction Of Its Sulphur And Salt**

Take good Hungarian Antimony, pulverise it subtilly to a meal, calcine it over a gentle heat, stirring it still with an Iron wire, and let it be albified and [become so] that at last it may be able to hold out in a strong fire. Then put it into a melting pot, melt it, cast it forth, turn it to a transparent glass, beat that glass, grind it subtilly, put it in a glass body of a broad, flat bottom, pour on it distilled Vinegar [and] let it stand luted in a gentle heat for a good while. The Vinegar extracteth the antimonial tincture, which is of a deep redness; abstract the Vinegar [and] there remaineth a sweet, yellow, subtile powder, which must beedulcorated with distilled water. All acidity must be taken off. Exiccate it, pour on it the best graduated Spirit of Wine [and] set it in a gentle heat. You have a new extraction, which is fair and yellow; cant it off, pour on other Spirit, let it extract as long as it can, then abstract the Spirit of Wine. Exiccate [and] you find a tender, deep yellow, subtile powder of an admirable medicinal operation, [which] is nothing inferior unto potable Sol.

Take two parts of this powder [and] one part of Solar Sulphur; grind these small, then take three parts of Sulphur of Mars, pour on it six parts of Spirit of Mercury, set it in digestion, well luted, let the Sulphur of Mars be dissolved totally, then carry in a fourth part of the ground matter of the Sulphur of Antimony and of Sol. Lute and digest. Let all be dissolved, then carry in more of your ground Sulphur [and] proceed as formerly, iterating it so long till all be dissolved; then the matter becomes a thick, brown oil. Drive all over jointly into one, leave nothing behind in the bottom; then pour it on a purely separated Lunary Calx, fix it by degrees of fire, then melt it into a body, separate it with an *aqua fort* [and] six times as much [more] of Sol is precipitated than did enter by weight into the ponderosity of the above compound<sup>340</sup>. The remainder of Lune serveth for such works as you please to put it unto.

The Antimonial tincture being extracted totally from its *vitrum*, and [when] no Vinegar takes more hold of any tincture, then exiccate the remaining powder, which is of a black colour; put it into a melting pot, lute it, let it stand in a reasonable heat [and] all the Sulphurous part burn away; grind the remaining

matter, pour on it new distilled Vinegar, extract its Salt, abstract the Vinegar, edulcorate the acidity by cohobation [and] clarify it so long that the water be white and clear. If you have proceeded well in your manuals, then the lesser time will be required to extract the antimonial Salt as you shall hear of it, whereby you may observe that the antimonial Sulphur is extracted in the following manner and is of the same medicinal operation, but is of a quicker and speedier work, worthy to be observed.

### **A Short Way To Make Antimonial Sulphur And Salt**

Take good Vitriol, common Salt and unslaked Lime, of each one pound, [and] four ounces of Sal Armoniack. Beat them small, put them in a glass body, pour on it three pound[s] of common Vinegar [and] let it stand in digestion, stopped, for a day. Put it afterwards into a retort, apply a receiver to it [and] distil it as usually an *aqua fort* is distilled. Take of the off-drawn liquor and of common Salt one pound of each, rectify them once more; let no muddiness come over with it; all must come clear. Then take one pound of pulverised antimonial glass, pour this Spirit on it, lute it well, digest and let all be dissolved. Then abstract the water *in Balneo Mariae* [and] there remains in the bottom a black, thick, fluid matter, but somewhat dry. Lay it on a glass table [and] set it in a cellar [and] a red oil floweth from it, leaving some feces behind. Coagulate this red oil gently upon ashes, let it be exiccated there, then pour the best Spirit of Wine on it [and] it extracteth a tincture which is blood-red. Cant off that which is tinged, pour other Spirit of Wine on the remainder and [by iteration] let all redness be extracted. Thus you have the tincture of antimonial Sulphur, which is of a wonderful medicinal efficacy and is equivalent unto potable gold as you were told before<sup>341</sup>. This black matter which stayed behind after the extraction of the Sulphur must be well exiccated. Extract its snow-white Salt with distilled Vinegar, edulcorate it, clarify it with Spirit of Wine and observe its virtues in medicine.

I have mentioned and demonstrated that all things are made and compounded of three essences, viz., of Mercury, Sulphur and Salt. But know this that the Stone is made of one, two, three, four and five<sup>342</sup>.

Of five, that is the quintessence of its matter; of four are understood the four elements; of three are the three principles of all things; of two, for that is the double mercurial substance; of one, that is the *Ens Primum* of all things, which flowed from the *fiat* of the first creation<sup>343</sup>.

Many well-minded artists may be doubtful, by all these sayings, to attain the foundation and discovery thereof. Therefore I shall first very briefly speak of Mercury, secondly of Sulphur, thirdly of Salt; for these are essences of our matter of the Stone.

First know that no common Argent Vive is made of the best metal by the Spagyric Art<sup>344</sup>, [but one that is] pure, subtile, clear, splendent as a fountain, transparent as crystal, without any impurity. Of this make a water or

incombustible oil<sup>345</sup>, for Mercury was at the first water, as all the philosophers agree.

In this mercurial oil dissolve its proper Mercury, out of which the water was made, and precipitate that Mercury with its proper oil; then have you a double mercurial substance. And know that your Gold must be first dissolved in a certain water after its purification and must be reduced into a subtile Calx as hereafter shall be declared at large. And then the said Calx must be sublimed by Spirit of Salt precipitated again and by reverberation reduced into a subtile powder; then its own proper Sulphur will the more easily enter into its own substance and be in amity with it, for they wonderfully love each other. So have you two substances in one and [it] is called the Mercury of the Philosophers and yet it is but one substance, that is, the first Ferment.

Your Sulphur you must seek in the like metal, then you must know how to extract it out of the body of the metal by purification and destruction of its form and reverberation without any corrosive. Then dissolve this Sulphur in its own proper blood, whereof it was made before its fixation, according to its due weight; then you have nourished and dissolved the true Lion<sup>346</sup> with the blood of the Green Lion<sup>347</sup>; for the fixed blood of the Red Lion is made out of the volatile blood of the Green Lion, therefore are they of one nature. And the volatile blood maketh the fixed blood volatile, and the fixed likewise maketh the volatile blood fixed as it was before its solution. Then set them together in a gentle heat until the whole Sulphur be dissolved; then have you the Second Ferment, nourishing the fixed Sulphur with the volatile as all philosophers agree with me herein. This afterwards is driven over with Spirit of Wine, red as blood, and is called *Aurum Potabile*, whereof there is no reduction to a body.

### **Of The Salt Of The Philosophers**

Salt maketh fixed and volatile according as in its degree it is ordered and prepared. For the Spirit of Salt of Tartar, if it be drawn per se and without addition, maketh all metals volatile by resolution and putrefaction and resolveth them into a true vive or current Mercury, as my practice declares.

Salt of Tartar *per se* fixeth most firmly, especially if the heat of Calx vive be incorporated with it, for both then have a singular degree of fixing.

So also the vegetable Salt of Wine both fixeth and maketh volatile according to the divers[e] preparation thereof, as its use requireth, which certainly is a great Mystery of Nature and a wonder of the philosophic Art.

If a man drink Wine and out of his urine a clear Salt be made, that is volatile and maketh other fixed things volatile and carrieth them<sup>348</sup> over the helmet with it, but it fixeth them<sup>348</sup> not, and although the man drink nothing but Wine, out of whose urine the Salt was made, yet it hath another property than the Salt of tartar or of the feces of Wine. For there is made a transmutation in the body of man, so that

out of a vegetable, that is out of a Spirit of Wine, an animal Spirit of Salt is made. Horses, by the corroboration of their natural virtue, do transmute oats, hay and such like and convert it into fat and flesh; so doth the bee make honey out of the best of flowers and herbs. So understand of other things. This key and cause consisteth only in putrefaction, from whence such a separation and transmutation taketh its original.

The Spirit of common Salt, which is drawn after a peculiar manner, maketh Gold and Silver volatile; if a small quantity of the Spirit of Dragon<sup>349</sup> be added to it, it dissolveth it and carrieth it over with it *per alembicum*, as also doth the Eagle with the Dragon's Spirit, which dwelleth in stony places; but if anything be melted with Salt before the Spirit be separated from its body, it fixeth much more than it volatiliseth.

If the Spirit of common Salt be united with Spirit of Wine and both be three times distilled over together, then it waxeth sweet and loseth its acrimony. This prepared Spirit doth not corporeally dissolve Gold; but if it be poured on a prepared Calx of Gold it extracteth its highest tincture and redness, which, if it be rightly done, it reduceth pure and white Luna into the same colour, whereof its<sup>350</sup> body was before it<sup>351</sup> was extracted. Also the old body<sup>352</sup> will again attain its colour by the love of enticing Venus, being descended from the same original, state and blood<sup>353</sup>.

Know also [that] the Spirit of Salt destroyeth Luna and reduceth it into a spiritual essence, from whence afterwards *Luna potabile* may be prepared, which Spirit of Luna is appropriated to the Spirit of Sol as man and wife by the copulation and conjunction of the Spirit of Mercury or its oil.

The Spirit lieth in Mercury; seek the tincture in Sulphur<sup>354</sup> and the coagulation in Salt<sup>355</sup>; then have you three matters, which may again produce some perfect thing, that is the Spirit of<sup>356</sup> Gold fermented with its own proper oil. Sulphur is plentifully found in the propriety of most precious Venus, which inflameth the fixed blood gotten of her. The Spirit of the philosophic Salt gives victory to coagulation, although the Spirit of Tartar and Spirit of Urine, together with the true *acetum*, may do much; for the Spirit of Vinegar is cold and the Spirit of Calx vive is very hot, therefore are they esteemed and found to be of contrary nature. This I faithfully declare. Seek your matter in a metalline substance, make thereof Mercury, which ferment with Mercury; then a Sulphur, which ferment with its proper Sulphur, and with Salt reduce it into order<sup>357</sup>; distil them together [and] conjoin them all according to their due proportion, then will it become one thing, which before came from one; coagulate and fix it by a continual heat, then multiply and ferment it three times.

The Key of the process discovering the Tincture is thus. When the Medicine and Stone of the philosophers is made and perfectly prepared out of the true *Lac Virginis*, take thereof one part, of the best and purest Gold, melted and purged by Antimony, three parts and reduce it into as thin plates as possibly you can; put

these together into a crucible wherein you use to melt metals. First give a gentle fire for twelve hours, then let it stand three days and nights continually in a melting fire; then are the pure Gold and the Stone made a mere Medicine of a subtile, a spiritual and penetrating quality. For without the ferment of Gold the Stone cannot operate or exercise its tingeing quality, being too subtile and penetrative; but being fermented and united with its like ferment, the prepared tincture obtaineth an ingress in operating upon other bodies. Then take of the prepared ferment one part to a thousand parts of melted metal, if you will tinge it, then know for a very certain truth that it shall be transmuted into good and fixed Gold; for one body embraceth the other, although they be not alike, yet by the force and power added to it, it is made like unto it, like having its origin from its like.

Note well that out of Black Saturn and friendly Jove a Spirit may be extracted, which is afterwards reduced into a sweet oil as its noblest part, which Medicine, *particulariter*, doth most absolutely take way the nimble, running quality from common Mercury and bringeth him to a melioration.

Having thus attained the matter, nothing remains but that you look well to the fire, that you observe its regimen, for herein is the highest concernment and the end of the work. For our fire is a common fire and our furnace is a common furnace, although some philosophers, to conceal the art, write the contrary<sup>358</sup>. The fire of the lamp with the Spirit of Wine is unprofitable; the expense thereof would be incredible. *Fimus Equinus* spoileth it, for it cannot perfect the work by the right degree of fire.

Many and various furnaces are not convenient, for in our threefold furnace only the degrees of heat are proportionately observed. And as our furnace is common so is our fire common and as our matter is common, so is our Glass likened to the Globe of the Earth.

### **Of Mercury**

There are several sorts of Mercury. Mercury of animals and vegetables is merely a fume of an incomprehensible being unless it be caught and reduced to an oil; then it is for use. But Mercury of metals is of another condition, as [is] that also of minerals, though the same, also, may be compared with a fume, yet it is comprehensible and running. One Mercury is better and nobler than the other, for the Solar Mercury is the best of them all. Next unto that is the Lunar Mercury and so forth. There is a difference, also, among Salts and Sulphurs. Among the mineral Salts that carrieth away the bell which is made of Antimony and that Sulphur which is drawn from Vitriol is preferred before all others. Mercury of metals is hot and dry, cold and moist; it containeth the four qualities.

There are medicaments prepared of it of a wonderful efficacy, of several sorts and forms, which is the reason why there is such a variety of virtues therein. In Mercury lieth the highest arcanum for man's health, but [it] is not to be used crude, but must first be prepared into its essence. It is sublimed with Copper water and is further reduced into an oil. There is an oil made of it *per se*, without

any corrosiveness, which is pleasant and fragrant. Several sorts of oils, with additionals, can be made of it, good for many things. It is prepared also with Gold, being first made into an *Amalgama*; there is made a precipitate of it in water, wherein it dissolveth green, like unto a Smaragd or Chrysolite. The volatile Mercury serveth for outward use, if a separation is made by some means and [if it] is brought into [a] subtile, clear liquor and then to a red-brown powder and its received corrosiveness is separated, then it may do well for other uses.

The mixed Mercury serveth for inward use. Mercury, being purged, is precipitated with the blood of Venus, is well digested with distilled Vinegar, and thus his corroding quality is taken off. Have a care what quantity you minister; if it is<sup>359</sup> given in a true dose, then it does its part very well. But for its operation it is not equally sublimed unto the fixed, its coagulation is found in Saturn, his malleableness is apparent when he is robbed of his life; he containeth his own tincture upon white and red, being brought in his fixed coagulation unto a white body, is tinged again by Vitriol water and being reduced to Gold is graduated by Antimony. Though that bloodthirsty Iron Captain with his spear assaulteth Mercury very much, yet he alone cannot conquer him unless cold Saturn come in to hide him and Jupiter command the peace with his sceptre. Such process being finished, when<sup>360</sup> the Angel Gabriel, the Strength of the Lord, and Uriel, the Light of the Lord, hath showed Mercury unto humble Michael, then Raphael can make right use of the highest Medicine<sup>361</sup>.

### Of Antimony<sup>362</sup>

It is very difficult to find out all the mysteries that are hid therein. Its virtue is miraculous; its power is great; its colour, hidden therein, is various; its crude body is poisonous; yet its essence is an antidote against poison [and] is like unto Quicksilver, which ignorant physicians can neither comprehend nor find, but the knowing physician believeth it to be true, having made many experiments with it.

This mineral containeth much of Mercury, much of Sulphur and little of Salt, which is the cause why it is so brittle and appliable; for there is no malleableness in it by reason of the small quantity of Salt. The most amity it beareth unto Saturn is by reason of Mercury, for philosophers' Lead is made out of it and is affected unto Gold by reason of its Sulphur; for it purgeth Gold, leaving no impurity in it. There is an equal operation in it with Gold if well prepared and [ad]ministered to man medicinally. It flieth out of the fire or<sup>363</sup> keeps firmly in the fire if it be prepared accordingly. Its volatile Spirit is poisonous, purgeth grievously [and] not without damage unto the body. Its remaining, fixed redness purgeth also, but not in that manner as the former did, provoketh not to stool but seeketh merely the disease whatever it is, penetrateth all the body and the members thereof, suffers no evil to abide there, expels it and brings the body to a better condition. In brief Antimony is the Lord in medicinals. There is made out of it a *Regulus* out of Tartar and Salt; if at the meeting of Antimony some Iron filings be added, by a manual used there cometh forth a wonderful Star, which philosophers before me called the Signet Star<sup>364</sup>. This Star being several times melted with cold earth

Salt, it groweth then yellowish, is of a fiery quality and of a wonderful efficacy. This Salt afterwards affords a liquor, which further is brought to a fix[ed], incombustible oil, which serveth for several uses.

Besides there are made of common Regulus of Antimony curious flowers, either red or yellow or white, according as the fire hath been governed. These flowers being extracted and the extract, without any addition, *per se* being driven into an oil, have an admirable efficacy. This extraction may be made also with Vinegar of crude Antimony or of its *Regulus*, but it requireth a longer time, neither is it so good as the former preparation.

And being reduced into a *Philistea* there is a glass made of it *per se*, which [if it] is extracted also, [and] then abstracted, there remaineth a powder of incredible operation, which may safely be used after it hath been edulcorated. This powder, being dissolved, healeth wounds, sores etc., causing no pains. This powder being extracted once more with Spirit of Wine, or driven through the helmet with some other matter, affords a sweet oil.

Antimony is melted also with cold earth Salt, dissolved and digested for a time in Spirit of Wine. It [then] affords a white fixed powder [which] is effectual against *Morbus Gallicus* [and] breaks inward imposthumes. It hath several virtues besides.

There is made an oil also of Antimony, the Flying Dragon<sup>365</sup> being added thereunto, which, being rectified thrice, then it is prepared. Though a cancer were never so bad and the wolf<sup>366</sup> never so biting, yet they, with all their fellows, be they fistulas or old ulcers, must fly and be gone. The little powder of the Flying Dragon prepared with the Lion's Blood, must be [ad]ministered also, three or four grains for a dose according to the party's age and complexion.

A further process may be made with this oil with the addition of a water made of stone serpents<sup>367</sup> and other necessary spices, not those that are transported from the Indies. This powder is of that efficacy that it radically cureth many chronical diseases. There is made a red oil of Antimony, Calx vive, Sal armoniack and common Sulphur, which hath done great cures in old ulcers; with stone Salt or with common Salt there is forced from Antimony a red oil which is admirable good for outward symptoms.

There is made a sublimate of Antimony with Spirit of Tartar and Salmiac<sup>368</sup>, being digested for a time, which by means of Mars is turned into quick Mercury. This antimonial Mercury hath sought of many but few have gotten it, which is the reason why his praise is not divulged, much less is his operative quantity<sup>369</sup> known. If you know how to precipitate it well, then your arrow will hit the mark to perform great matters; its qualities ought not to be made common [knowledge]. It is needless to describe its combustibile Sulphur, how that is made out of Antimony; it is easy and known; but that which is fixed is a secret and hidden

from many. If an oil be made of it in which its own Sulphur be dissolved and these be fixed together, then you have a Medicine of rare qualities, in virtue, operation and ability far beyond vegetables.

Quicksilver being imbibed with Quicksilver melted with Antimony for some hours in a wind oven, the Salt of the remainder being extracted with distilled Vinegar, then you have the philosophers' Salt, which cureth all manner of agues.

There is an *acetum* made of Antimony, of an acidity as other *acetums* are; if its own Salt be dissolved in this *acetum* and distilled over, then this *acetum* is sharpened, which is an excellent cooler in hot swellings and other inflamed symptoms about wounds, especially if there be made an unguent of it together with *anima* of Saturn.

There is a quintessence of Antimony, which is the highest Medicine, the noblest and subtlest found in it and [it] is the fourth part of an Universal Medicine. Let the preparation of it be still a mystery. Its quantity or dose is three grains. There belong four instruments to the making of it; the furnace is the fifth, in which Vulcan dwelleth; the manuals and the government of the fire afford the ordering of it.

#### **Of Copper -- water**

Copper is a mineral whose Salt is set forth in the highest manner, whose<sup>370</sup> great and good qualities are of the transcendancy that reason is not able to comprehend or to conceive of them. It went generally by the name of Copper-water to make the meaning and sense of it plain. And be thus informed that Vitriol containeth two Spirits, a white and a red one; the white is the white Sulphur upon white, the red Spirit is the Red Sulphur upon red.

Observe it diligently. The white Spirit is sour, causeth an appetite and a good digestion in a man's stomach; the red Spirit is yet sourer and is more ponderous than the white; in its distilling a longer fire must be continued because it is more fixed<sup>371</sup> in its degree. Of the white, by distilling with<sup>372</sup> Sulphur of Lune, is made *Argentum potable*. In the like manner the Gold<sup>373</sup>, being destroyed in the Spirit of common Salt and made spiritual by distilling and its Sulphur taken away from it and joined with a red Spirit in a due dose, that it may be dissolved and then for a time putrefied in Spirit of Wine, to be further digested and often abstracted that nothing remain in the bottom, then you have made an *Aurum potable* of which great volumes have been written, but very few of their processes were right.

Note that the red Spirit must be rectified from its acidity and brought into a sweetness subtly penetrating? of a pleasant taste and sweet fragrancy.

The sweet Sulphur is made of Sulphur of Vitriol, which is combustible like other Sulphur before it is destroyed. For the Sulphur of the philosophers is not combustible. Note this well. The preparation is easy [and] requireth no great

pains nor great expenses to get a combustible Sulphur out of Vitriol. This sweet oil is the essence of Vitriol and is such a Medicine which is worthy the name of the Third Pillar of the Universal Medicine. The Salt is drawn from Colchotar<sup>374</sup> and is dissolved in the red or white oil or in both and is distilled again; if it be fermented with Venus it performeth its office very well, for it affords such a Medicine which at the melting tingeth pure Iron into pure Copper.

Colchotar of Sulphur affords true fundamentals unto [the] healing of perished wounds, which otherwise are hardly brought to any healing, and such sores which by reason of a long continued white redness will admit of no healing. Colchotar affords an ingress thereunto, setting a new foundation that quality and virtue are not in the Colchotar, but the Spirit, together with the Salt, are the matters which dwell therein.

There is made of Copper and Verdigris a Vitriol of a high degree, which<sup>375</sup> is far spread in its tincture. There is a Vitriol made of Iron also, which is of a strange quality; for Iron and Copper are very nigh kind<sup>376</sup> one to another, belong[ing] together as man and wife. This mystery I would have concealed.

[When] Vitriol [is] corroded with Sal Armoniack in its sublimation, there ariseth a combustible Sulphur together with its Mercury, of which there is but little because it hath most of Sulphur. If the same Sulphur be set at liberty again by the Eagle<sup>377</sup> with Spirit of Wine, there can be made a Medicine of it, as I told you before, though there be a nearer way to make combustible Sulphur out of Vitriol, as of its precipitation upon a precedent dissolution by the Salt or Liquor of Tartar, as also by a common *lixivium* made of Beech-ashes; yet this is the best reason, because the body of Vitriol is better and more opened with the Key of the Eagle<sup>377</sup>. There is not found in its nature either cold or moist quality, but [it] is of a hot and dry, substantial quality and [this] is the reason why, by its superabounding calidity, it heateth other things, digesteth them and at last it bringeth them to a full maturity, the fire being continued for a certain time.

### **Of Common Sulphur**

The usual common Sulphur is not so perfectly exalted in its degree and brought into maturity as [when] it is found in Antimony and Vitriol. There is made of it *per se* an oil against putrid, stinking wounds, destroying such worms which grow in them, especially if the little Salt in it be dissolved from its Sulphur.

There is made of it a balsam with Sallet oil<sup>378</sup> or oil of Juniper, in like manner with the white Spirit of Turpentine, and [it] is of a red colour [and] is made thus. Take o? Flowers of Sulphur made with Colchotar of Vitriol and digest them for a time in horse-dung. This balsam may safely be used for such that are in a consumption of the lungs, especially [if it] be rectified several times with Spirit of Wine, drawn over and separated, that it be blood red. This balsam is a preservative against corruption and rottenness.

The quintessence of Sulphur is [found] in a mineral where a sulphureous flint is generated. Thus [let] beaten pebbles [be] put in a glass and on it be poured a strong *aqua fort*, made of Vitriol and Saltpeter, and let dissolve what may be dissolved, [then] abstract the water; the remainder must be well dulcified and reverberated to a redness; pour on that Spirit of Wine, extract its tincture [and] afterwards circulate for a time in the Pelican; let all the essence of Sulphur be separated, it stayeth below the Spirit of Wine like [a] fat Sallet oil, by reason of its ponderousness; its dose of six grains is found to work sufficiently. If you digest in this essence of Sulphur, Myrrh, Aloes and other Spirits, it extracts their virtues and makes them<sup>379</sup> into a balsam, which suffers no flesh or other parts that are subject to putrefaction to fall into rottenness, for which reason the ancients have put this name to it, *Balsamus mortuorum*. There may be made an oil of it<sup>380</sup> which is found very useful. The Sulphur may be sublimed in a high instrument with a good heat, which sublimation in a long time changeth [it] into a liquor or oil [if left] standing in a humid place.

There may be cocted a Liver out of common Sulphur, which is turned into milk, and it may also be changed into a red oil. Many other Medicinals may be made out of Sulphur. Its Flowers, Essence and Oil are preferred before the rest, together with the white and red fixed Cinnabar<sup>381</sup> which are made of it, because in them is found a mighty virtue.

### Of Calx Vive

The secrets of Quicklime are known to few men and few there are which attained to a perfect knowledge of its qualities. But though Lime is contemptible, yet there lieth great matters therein and [it] requireth an understanding master to take out of it what lieth buried in it. [By this] I mean to expel its pure Spirit, which colaterally stands in affinity with minerals, is able to bind and help to make fix[ed] the volatile Spirits of minerals, for it is of a fiery essence [and] heateth, concocteth and bringeth [them] unto maturity in a short time, when in many years they could not [otherwise] be brought to it. The gross, earthly body of it doth not do the feat, but its Spirit doth it, which is drawn out of it. This Spirit is of that ability that he bindeth and fixeth other volatile Spirits.

For note, the Spirit dissolveth *Occuli cancrorum*<sup>382</sup>, dissolveth crystals into a liquor. These two being duly brought into an unity *per modum distillationis* (I will say nothing now of Diamonds and such-like stones) that water dissolveth and breaketh the stones in the bladder and the gouty Tartar settled into the joints of hands and feet [and] suffers not any gout to take root in those parts. This is a rare secret. Quick Lime is strengthened and made more fiery and hot by a pure and unsophisticated Spirit of Wine, which is often [to be] poured on it and abstracted again; then the white Salt of Tartar must be grinded with it, together with its additional which must be dead and contain nothing, then you will draw a very hellish Spirit, in which great mysteries lie hid.

### **Of Arsenick**

Arsenick is in the kindred of Mercury and Antimony as a bastard in a family may be. Its whole substance is poisonous and volatile, even as the former two; in its external colour to the eye it is white, yellow and red, but inwardly it is adorned with all manner of colours, like to its metals, which it was fain to forsake, being forced thereunto by fire. It is sublimed *per se* without additions and also in its subliming there are added several other matters as occasion requireth. If it be sublimed with Salt and Mars, then it looks like a transparent crystal, but its poison stayeth still with it, unfit to be joined or added to metals [and it] hath very little efficacy to transmute any metals.

The subterranean Serpent bindeth it in the union of fire, but cannot quite force it that it might serve for a Medicine for man and beast. If it be further mixed with the Salt of a Vegetable Stone<sup>383</sup>, which is with Tartar<sup>384</sup>, and is made like unto an oil, it is of great efficacy in wounds which are of an hard healing. It can make a coat for deceitful Venus, to trim her handsomely, that the inconsistency of her false heart may [not?] be disclosed by her wavering servants, without gain, with her prejudice and damage. When Antimony and Mars are made my companions [saith Arsenick], and [I] am exalted by then to the top of Olympus, then I afford a Ruby in transparence and colour [like un]to that which cometh from [the] Orient and I am not to be esteemed less than it. If I am proved by affliction, then I fall off like a flower which is cut off and withers, therefore nothing can be made of me to fix any metal or tinge it to any profit.

### **Of Salt Peter**

Two elements are predominant in me, as fire and air; the lesser quantity is water and earth. I am fiery, burning and volatile. There is in me a subtile Spirit, I am altogether like unto Mercury, hot in the inside<sup>385</sup> and cold in the outside. [I] am slippery and very nimble at the expelling of my enemies. My greatest enemy is common Sulphur and yet is [he] my best friend also, for being purged by him and clarified in the fire, then am I able to allay all heats of the body within and without and am one of the best Medicaments to expel and keep off the poisonous plague.

I am a greater cooler outwardly than Saturn, but my Spirit is more hot than any. I cool and burn according as men will make use of me and according as I am prepared. When metals are to be broken I must be a help, else no victory can be obtained, be the understandings great or small. Before I am destroyed I am a mere ice, but when I am anatomised, then am I an hellish fire.

### **Of Sal-armoniack**

Sal-armoniack is none of the meanest Keys to open metals thereby, therefore the ancients have compared it with a volatile Bird. It must be prepared, else you can do no feats with it, for if it be not prepared it doth more hurt than good unto metals [and] carrieth them away out of the chimney hole. It can elevate and sublime with its swift wings the tincture of minerals and of some metals to the very mountains, where store of snow is found usually, even at the greatest heat

of summer. If it be sublimed with common Salt, then it purgeth and cleareth and may be used safely.

He that supposeth to transmute metals with this Salt, which is so volatile, surely he doth not hit the nail on the head, for it hath no such power; but to destroy the metals and make them fit for transmutation, in that respect it hath sufficient power, for no metal can be transmuted unless it be first prepared thereunto.

### **Of Tartar**

This Salt is not set down in the book of minerals but is generated of a vegetable seed<sup>386</sup>, but its Creator hath put such virtue into it that it beareth a wonderful love and friendship unto metals, making them malleable. It purgeth Lune unto a whiteness and incorporateth into her such additional which are convenient for her; being digested for a time with minerals or metals and then sublimed and vilified<sup>387</sup>, they all come into a quick Mercury, which to do there is not any vegetable Salt besides it. Many mysteries lie hid in it. It is a good remedy either outwardly or inwardly in Medicine; its Salt being made spiritual and sweet it dissolveth and reaketh the stone in the bladder and dissolveth the coagulated Tartar of the gout settled into the joints or anywhere else besides. Its ordinary Spirit, which is used for [the] opening of metals, being used and applied outwardly, layeth a foundation for healing such ulcers which admit hardly any healing, as fistulas, cancers, woles and such-like.

### **Of Vinegar**

In Alchemy and Medicine nothing, almost, can be prepared but Vinegar must set a helping hand to it. In Alchemy it is used to set metals and minerals into putrefaction. It is used also for to extract their essences and tinctures, being first prepared thereunto even as the Spirit of Wine is usual to extract the tinctures from vegetables.

In Physic it deserveth its praise also, for it taketh the pure from [the] impure and is a separator and taketh from the mineral Medicaments their sharpness and corrosiveness, fixeth that which is volatile and is a great defender against poison. Vinegar is used inwardly also and both men and beasts are benefited thereby. Outwardly it is applied to hot inflammations and swellings for a cooler. Spirit of Wine and Vinegar are of great use both in Alchemy and Physic. Both have their descent from the Urine [and] are of one substance, but differ in the quality by reason of [the] putrefaction the Vinegar got there. But this is not the philosophers' Vinegar. Our Vinegar or *Acetum* is another liquor, namely a matter itself<sup>388</sup> for the Stone of [the] Philosophers is made out of the Azot of [the] Philosophers, which must be prepared with ordinary distilled Azot, with Spirit of Wine and with other waters besides and must be reduced unto a certain order.

Note this for a memorandum. If distilled, pure Vinegar be poured upon destroyed Saturn and is kept warm in Mary's Bath, it looseth its acidity altogether [and] is as sweet as sugar; then abstract two or three parts of that Vinegar, set it in a cellar

[and] then you will find white, transparent stones like unto crystals. These are an excellent cooler and healer of all adust<sup>389</sup> and inflamed symptoms.

If these crystals are reduced into a red oil and poured upon Mercury precipitated by Venus and proceeded in further as it ought; if that [I say] be done<sup>390</sup> rightly, then neither Sol nor Lune will hinder thee from getting riches.

### Of Wine

The true Vegetable Stone is found in Wine, which is the noblest of all vegetables. It containeth three sorts of Salt, three sorts of Mercury and three sorts of Sulphur.

The first Salt sticketh in the wood of the Wine, which, if [it be] burnt to ashes and a *lixivium* made of it [is able to] have its Salt drawn forth, which must be coagulated. This is the first Salt.

The second Salt is found in Tartar, if that be incinerated; then draw its Salt forth, dissolve and coagulate it several times and let it be sufficiently clarified.

The third Salt is this. When the Wine is distilled it leaveth feces behind, which are [to be] made to powder; its Salt can [then] be drawn out with warm water.

Each of these Salts hath a special property. In their centre they stand in a harmony, because they descend from one root.

It hath three sorts of Mercury and three sorts of Sulphur. The first oil is made of the steam, the second oil is made out of crude Tartar, the third is the oil of Wine.

There is a strange property in the Spirit of Wine, for without it there cannot be extracted any true tincture of Sol, nor can there be made without it any true *Aurum Potabile*; but few men know how a true Spirit of Wine is made, much less can its property be found out wholly. Several ways have been tried to draw and to get the Spirit of Wine without sophistication, as by several instruments and distillings with metalline Serpents and other strange inventions, of sponges, papers and the like. Some caused a rectified *Aqua vitae* [to] be frozen in the greatest frost, expecting the phlegm thereof should turn to ice [and] the spirit thereof to keep liquid, but nothing was done to any purpose.

### To Make A True Spirit Of Wine

Take *Vinum Adustum*<sup>391</sup> and put it into a strong Vessel, which will endure the fire; light it with a match of Brimstone and put quickly a head of Iron or Copper upon it and the true, fiery Spirit will be resolved into a water in the receiver, which must be large. This is the true aerial, fiery Spirit of Wine. It must be subtile, penetrating, without any phlegm, pure, aerial and volatile, so that air in a magnetic quality may attract it; therefore it had need to be kept close in. It is of a penetrating and effectual operation.

There are three which are the noblest creatures in the world; these three have a wonderful affection one to another<sup>392</sup>. Among animals it is man, out of whose Mummy is made an Animal Stone, in which [the] Microcosm is contained. Among minerals Gold is the noblest, whose fixedness is a sufficient testimony of its noble offspring<sup>393</sup> and kindred. Among vegetables there lieth hid a Vegetable Stone<sup>394</sup>. Man loveth Gold and Wine above all other creatures, which may be beheld with the eyes. Gold loveth Man and Wine, because it lets go its noble part if Spirit of Wine be put to it, being made potable, which giveth strength to Man and prolongeth his life in health. Wine beareth affection to Man also and to Gold, because it easily uniteth with the tincture of Sol, expelleth melancholy and sadness [and] refresheth and rejoiceth Man's heart. These Stones renew men and beasts, cure leprous metals and cause barrenness to become fruitful with a new birth.

### **The True Preparation Of Aurum Potabile Without Sophistication**

First [I will describe] what is that true and highest *Aurum potable* and Universal Medicine. After this in order there followeth another *Aurum potable* made of the fixed red Sulphur or Soul of the corporeal Gold, most highly purged, and [it] is prepared with the conjunction of the Universal Spirit of Mercury. After this there followeth another particular Medicine, which is half an *Aurum potable*, showing its efficacy and power in many trials. Then I will add thereunto a description of *Aurum potable*, because it traceth the steps of Gold and it showeth wonderfully its great energy and virtues.

The highest and chiefest *Aurum potable* which the Lord god hath laid into Nature is the excocted, prepared and fixed substance of our Stone before it is fermented. A higher, greater and more excellent Universal Medicine and *Aurum potable* cannot be found nor had in the circumference of the whole world; for it is a heavenly balsam because its first principles and original cometh from heaven, made formal in earth or under ground, and is afterwards, being exactly prepared, brought into a *plusquam* perfection, of which first principle and nativity of this heavenly substance I have already writ sufficiently.

Now as this excocted and perfect substance is the highest, chiefest and greatest Universal Medicine unto man, even so, on the other side, the same matter, after its fermentation, is a tincture also and the chiefest, greatest and most powerful Universal Medicine upon all metals whatsoever and thereby [they] may be transmuted into their highest melioration and health, namely into the purest Gold.

This is the first, chiefest and greatest *Aurum potable* and Universal Medicine of the whole world, of which alone great volumes could be writ, whose preparation is already written.

Now I will declare the true and full process how a true *Aurum potable* is to be made.

How true *Aurum potabile* is to be had and prepared from Gold, which in the best manner is exactly putrefied. Take the extracted Soul of Gold, draw[n] forth with the sweet Spirit of common Salt, as I informed you about the Particular of Gold<sup>395</sup>, where the body of Gold appeared very white; abstract the Spirit of Salt from it; edulcorate the *anima* of Sol ten or twelve times [and] at last let it be exiccated. Weigh it; pour on it four times as much of Spirit of Mercury; lute it well; set it in the Vaprous bath [and] putrefy it gently. Let the *anima* of Sol be quite dissolved and be turned into water or its *prima materia*. Both will turn into a blood-red liquor, fair and transparent, no Ruby on the earth [being] comparable unto it.

But note, when the *anima* of Sol begins to be dissolved and brought into its *prima materia*, that at the first, on the side round the glass where the matter lieth there [will] be seen a green circle, on it a blue, then a yellow. Afterwards all the colours of the rainbow join and make appearance, which do but last a little while<sup>396</sup>. The *anima* of Sol being wholly dissolved into the Mercurial Spirit, and [when] nothing is seen in the bottom, then pour to it twice as much of the best rectified Spirit of Wine, brought to its highest degree. The glass must be luted exactly. Digest and putrefy gently for twelve or fifteen days together, then abstract *per alembicum*, [when] the matter cometh over in a blood-red, transparent colour. This abstracting must be iterated; nothing must be left in the bottom which is corporeal; then you have the true *Aurum potabile*, which can never be reduced into a body.

But note, the Gold, before its destruction and [the] extraction of its Soul, must be purged in the highest degree. There is made another *Aurum potabile* and [one that is] artificially prepared, which, though it cannot be said or set down in writing to be the full and true potable Gold, yet is it [counted] more than half an *Aurum potabile* because it is transcending effectual in many diseases in which Nature might have stood in great doubts. This half *Aurum potabile* is made in a two-fold manner, where the latter is better and more effectual than the former and asketh more pains and time than the former.

Take this extracted Soul of Gold drawn forth with the sweet Spirit of common Salt, edulcorate it most purely and exactly [and] at last exiccate it [and] put it in a spacious viol or body of glass. Pour on it red oil of Vitriol, which was dephlegmed and rectified *per retortam* that it be transparent, clear and white and you see that it seizeth on the Gold and dissolveth it and is tinged deeply red. Put so much of this oil to it that in it may be dissolved [the] Sulphur or the Soul of Gold. Let it putrefy in *Balneo Mariae* [and] put a reasonable fire to it, that you may see that the Soul of Gold is quite dissolved in the oil of Vitriol. The feces which it hath settled must be separated from it; then put twice as much of the best rectified Spirit of Wine to it, which rectification you shall be further informed of, seal the glass, let no Spirits of Wine evaporate [and] set it again in putrefaction in the *balneum*; let it be there for a month, then the sharpness of the Vitriol is mitigated by the Spirit of Wine and loseth its acidity and sharpness [and] both together

make an excellent Medicine; drive both over [and] let nothing stay behind in the bottom, then you get more than half an *Aurum potabile*, in form and colour of a deep yellow liquor.

Note that some metals in this manner may be proceeded withal. First a Vitriol may be gotten out of the metal, then a Spirit is further driven from it and joined in this manner with the Soul [and] dissolved and further digested with Spirit of Wine. All must enter into a Medicine as I formerly said, which [Medicines] have their special efficacy.

The second way to prepare this half *Aurum potabile*, which though it be but half an *Aurum potabile*, yet in virtue and efficacy, is far preferred before the other now spoken of, is done as followeth<sup>397</sup>.

Take the extracted solar Soul spoken of above, put it into a viol [and] pour on it the extracted philosophic Sulphur, which is the second principle, which is drawn with Spirit of Mercury from the philosophers' earth and Mercury, or Spirit of Mercury, unto an oleity, which now is Sulphur again and must be abstracted gently *per modum distillationis*.

Of this philosophic Sulphur pour on it as much that the solar Soul may be dissolved. Let it stand in a gentle bath, let the dissolution be made, then pour more of the best Spirit of Wine to it, digest gently, draw these over, let nothing stay behind in the bottom [and] then you have a Medicine that shall not want above two grains of the right and true *Aurum potabile*.

Those are the chiefest ways to make the corporeal *Aurum potabile*. This I close and proceed further with a short but true process how the Silver, which is the next to Gold concerning perfection, is made potable also. This process must be done in the following manner.

Take the sky-coloured Sulphur or Spirit of Lune, which was extracted with distilled Vinegar as I informed you in the particular of Lune<sup>398</sup>, edulcorate it, rectify it with Spirit of Wine, exccate it, put it in a viol, pour to it three times as much of Spirit of Mercury, which is prepared from the white Spirit of Vitriol as I taught you before, lute the glass firmly, set it in putrefaction in the vaprous bath [and] let all be dissolved and nothing more see in the bottom. Then put to it an equal quantity of the best Spirit of Wine, set it in digestion for half a month, drive all over, let nothing stay behind [and] then you have the true potable Luna which in its efficiency is admirable and doth wonders when it is used.

### **A Description Of The Fiery Tartar**

Distil of good Wine a Spirit of Wine, rectify it with white calcined Tartar, let all come over [and] put that which is distilled over into a viol. Pour four ounces of well sublimed Sal-armoniack to one quart of Spirit of wine, set a helmet upon [it],

set a great receiver into cold water [and] drive the volatile Spirits into [it] gently *in Balneo Mariae*. Leave but a little quantity of it behind. Note the alembick must always be cooled with wet cloths, then the Spirits will be dissolved and turn into a liquor. Thus is prepared this hot Spirit of Wine.

### **Of The Salt Of Tartar**

First you must note that the philosophers' Tartar is not the vulgar Tartar, wherewith the lock is opened, but it is a Salt which cometh from root<sup>399</sup> and is the only mystical Key for all metals and is prepared thus: Make a sharp *lixivium* of the ashes of Sarments<sup>400</sup> or twigs of the vine<sup>401</sup>, boil away all its moisture [and] there stayeth behind a ruddy matter, which must be reverberated for three hours in a flaming fire. Stirring it still, let it come to a whiteness, which white matter must be dissolved in distilled rain water; let the feces of it settle [and] filter and coagulate them in a glass, that the matter in it be dry, which dry matter is the Salt of Tartar from which the true Spirit is driven<sup>402</sup>.

Note. As precious stones have many rare virtues and qualities, so there are many despicable and ignoble stones, which have great virtues, [as] for example the Limestone, Calx vive, which in men's judgements is held of no great value and lieth contemptibly in obscurity; however there is a might virtue and efficacy in it which appeareth if application be made of it to the most heaviest diseases, seeing that its triumphant and transcendent efficacy is almost unknown for the generality; therefore for the good of such which are inquisitive into natural and supernatural mysteries I will discover this mystery concerning Calx vive and show how its Spirit is driven from it, which work, indeed, requireth an expert artist who is well informed aforehand of its preparation.

Take unslaked Lime as much as you will; beat and grind it on a well dried stone to an impalpable powder [and] put on it so much of Spirit of Wine as the pulverised Calx is able to drink. There must not stand any of that Spirit upon it. Apply a helmet to it and lute it well and put a receiver before it [and] abstract the Spirit from it gently *in Balneo*; this abstracting must be iterated eight or ten times. This Spirit of Wine strengtheneth the Spirit of Calx mightily and [it] is made more fiery hot. Take the remaining Calx out of the body, grind it very small and put to it a tenth part of Salt of Tartar, which is pure, not containing any feces.

As much as this matter weigheth together, add as much of the additional of Salt of Tartar thereunto, namely the remaining matter from which was extracted the Salt of Tartar, and it must be well exiccated. All this must be mingled together and put in a well coated retort. Three parts of the retort must be empty. Lute<sup>403</sup> a great receiver or body to it very strongly. Note [that] the body into which the retort's nose is put must have a pipe of a finger's breadth unto which may be applied another body and a quantity of Spirit of Wine in it. Then give a gentle fire to it. At first there comes over some of the phlegm, which falls into the first applied body. The phlegm being all come over, then increase the fire [and] there cometh a white Spirit to the upper part of the body, like unto the white Spirit of

Vitriol, which doth not fall among the phlegm but slideth through the pipe into the other body [and] draweth itself into the Spirit of Wine, embracing the same as one fire doth join with the other. Note [that] if the Spirit of Calx be not prepared first by the Spirit of Wine and drawn off and on as I told, then he does not so, but falleth among the phlegm where he is quenched [and] loseth also all his efficacy. Thus difficult a matter is it to search Nature th[o]roughly, [she] reserving [as she does] many things unto herself. This Spirit being fully entered into the Spirit of Wine, then take off the body [and] put away the phlegm, but keep carefully the Spirit of Wine and Spirit of Calx.

Note both these Spirits are hardly separated because they embrace closely one another and being distilled they come over jointly.

Therefore take these mixed and united Spirits, put them into a jar-glass [and] kindle it; the Spirit of Wine burneth away, [but] the Spirit of Calx stayeth in the glass; keep it carefully. This is the great arcanum; few of other Spirits go beyond its efficacy if you know how to make good use of it. This Spirit dissolves *occuli cancrorum*<sup>404</sup> [and] the hardest crystals. These three being driven over together and often iterated in that distilling, three drops of that liquor being ministered in warm wine break and dissolve any gravel and stone in man's body, expelling their very roots [and] not putting the patient to any pain.

This Spirit of Calx at the beginning looks bluish [but] being gently rectified [it] looks white, transparent and clear, leaving few feces behind. This Spirit dissolveth the most fixed jewels and precious stones. On the other side he fixeth all volatile Spirits with his transcendent heat.

This Spirit conquereth all manner of podagrical<sup>405</sup> symptoms, be they never so nodose<sup>406</sup> and tartarous; [it] dissolves them and expels them radically.

#### **Of Vitriol And Its Preparation As Also Of Its Power And Virtue**

Take good Hungarian Vitriol, calcine it till it be of a yellowish colour and no higher; grind this calcined Vitriol very small, put it into a distilling vessel with a long neck, well luted, *luto sapientiae*. Put thereto a large receiver and begin to distil day and night with a very gentle fire, that gives not a stronger heat than the Sun doth in a hot day. Afterwards increase the fire by degrees, forcing at last the Spirits with the strongest fire, till red, visible drops do come over, which work hath taken up three days and nights. This being done take that which is left in the distilling vessel, commonly called *Caput Mortuum*, and grind it small. Pour on it clean rain water, first distilled, and boil therein the Cholcotar and the Salt of Vitriol will go into the water. The water being settled and clear, filter it that the feces may be separated. Let the water vapour away in some glass vessel till the Salt be dry, [then] dissolve the Salt again in rain water, first distilled and let it vapour away again to dryness. Repeat this operation the third time and the Salt of Vitriol will be very fair, clean and clear. Put this dry Salt into a crucible of glass and pour

on it the above made Spirit of Vitriol; lute the glass *luto sapientiae* and set it in digestion for some days. This being done, open the glass and put the materials together into a retort of glass and distil them [at] first gently; and when it ceaseth to drop, increase the fire and force it over till nothing will come more. Let it become cold and then take the Spirit out of the receiver, which must be somewhat large and strong. Put the Spirit into a glass body and rectify it by distillation till it be freed from the phlegm and the matter in the glass body appear to be of a red-brown colour.

Then take the glass body and set it with the said matter in a cellar and there will shoot from it very clear, white, transparent crystals. Put these transparent crystals into a large phial with a very large and long neck and pour on them the first white Spirit of Turpentine and it will boil up and foam; therefore you must be careful and not over hasty in doing this. The crystals will dissolve and the Spirit of Turpentine will grow transparent [and] as red as blood. This being done, pour on it three times the weight of common Spirit of Wine freed fully from its phlegm, so that it stand two fingers high above it. Then put a little head of glass upon the neck of the phial, luting it well, join it to a receiver and distil very gently the Spirit of Wine *in Balneo Mariae* and the tincture of Vitriol comes over very pleasant[ly] with the Spirit of Wine and that which is corrosive remains behind with the oily parts of the Spirit of Turpentine. The Spirit of Wine being come with the tincture, put it together into another phial and pour on it some fresh Spirit of Wine and distil again gently *in Balneo Mariae* as you did before; if any corrosive be come over with the fire it will now stay behind. Repeat this operation the third time and the work is done and perfect. Put this fair, red, transparent Spirit of Vitriol into a Pelican, add to it at once half an ounce of well pulverised Unicorn's horn<sup>407</sup> and let it stand in circulation in a gentle heat a whole month. Then pour it off very clear from the feces and the tincture of Vitriol is prepared for the Medicine, of a very pleasant taste, and is to be used after this manner following, to wit: Let him that is troubled with the falling sickness<sup>408</sup> take half a dram of it in a spoonful of *Lillum Convallium* water when the fit is coming upon him. Thus let him use it three times and the Medicine will cure him by the help of God. He that is mad and distracted should take it likewise in Wine for the space of eight days and he will have reason to give God thanks for it. Moreover if it be taken in wine it doth resolve any hardness settled in the nerves and if it be constantly used for some time, even the gout itself is consumed and cured thereby.

Likewise it maketh those who are melancholy and troubled with sadness, if it be used as before, very cheerful and light-hearted; it dispelleth all sadness and breedeth good and pure blood. It hath been found very excellent in swimings and giddiness in the head; it comforteth the brain and preserveth the memory. If it be administered in consumptions of the lungs and any other coughs in the manner aforesaid, it will cure those distempers and is very useful for many other things.

### **An Addition**

Take Sal Armoniack, dissolve a considerable quantity of it in the strongest Vinegar and add to it filings of Copper. Let it putrefy in heat till the filings are all grown friable so that they may be grinded into powder and you will have a yellow powder, which edulcorate well.

Having done so, dry the powder and pour on it the red *Aqua Vitae Vitrioli*, which hath been distilled over with its proper Salt, so that it cover it all over. Set it thus in heat and the powder of the Copper will be dissolved in the oil, but there must be some fair water be mixed with it. Then draw it off in sand to dryness and the phlegm comes over. The remainder force out of a retort in an open fire and you will find an *Oleum Veneris*, green [and] transparent like an Emerald. Put again into this *Oleum* some of the powder of Copper and it will be dissolved in it. Then coagulate to dryness and you have a powder, half an ounce whereof will transmute a whole pound of Iron, being in flux, into very good Copper.

### **Of The Sweet Essence Of Vitriol**

The sweet Essence of Vitriol, whereby many wonderful cures may be wrought, is only prepared out of its Sulphur, which burneth like other Brimstone. To obtain this proceed after this manner. Take of the best Vitriol you can get [and] dissolve it in fair fountain water; after this take Pot-ashes, such as dyers use for their dyeing [and] these dissolve likewise in fair fountain water; let it settle well and then pour off the clear from the dregs and add it to the solution of Vitriol and one will enflame the other and cause a separation. For the Sulphur of Vitriol doth separate itself by precipitation. Make a considerable quantity of it and edulcorate it from all impurity. Afterwards dry the same Sulphur, which will burn like other Sulphur, being cast upon glowing coals.

Take now this Sulphur and sublime it by itself without any addition and there will remain some feces, which separate and put away. Then take the Sulphur and grind together with it half its weight of common Salt of Tartar and distil them together through a retort and there will come over a reddish oil. Pour to this oil some distilled Vinegar and there will precipitate a brown powder and the Spirit of Tartar remaineth in the water. Edulcorate the same powder very well, for therein is the treasure to be looked after. This work being done, pour some Spirit of Wine on the said powder and let it circulate in heat for eight days. Thus the excellent sweet Essence of the Sulphur of Vitriol goeth into the Spirit of Wine and swimmeth upon the top, *in forma olei*, like an oil of cinnamon. Then separate the essence from the Spirit of Wine by means of a separating glass and keep it very carefully for use, it being a great treasure.

### **The Use Of This Medicine**

This Essence of Sulphur, four grains of it being taken in Balm water, drieth up the bad humours of the blood, strengtheneth and incites men and women to copulation, cleanseth the womb, hindreth the rising of the mother and breedeth good sense for the procreation of children.

The same quantity being taken in parsley water and continued for a fortnight, doth consume all phlegmatic humours of the whole body cures the dropsy radically, drives out the putrefied blood [and] openeth imposthumes, yea you will find it do wonderful cures if you will be industrious and careful in the preparation thereof; but you must never whilst you live forget God your Creator, to call upon Him for a blessing and to render to Him thanks for all His fatherly benefits He hath bestowed upon you.

### **The Preparation Of The Stone Ignis<sup>409</sup>**

Now I will teach you the chiefest preparation of Antimony and the use of it in Medicine. In this Antimony are hidden and found so many wonderful mysteries that there is none too old to learn and to search to find them out. I will instruct you to make some preparations which are also required to other things.

Take pure mineral Antimony, which is brought from Hungary, grind it very small and wash it very clean, that the earth may be separated from it. Take then a pound of it, mix with it as much of fluxing powder and melt it once again and then the *Regulus* will be clean and pure.

Add to this *Regulus* its weight of Nitre and melt it down. Pour it out together and beat off the *Scoriae* and put again to the *Regulus* its weight of Nitre and melt it.

Repeat this till all is gone into *Scoriae*, which you must carefully keep; they will burn upon the tongue like fire. This being done, take the matter so gathered, grind it small and edulcorate the Salt-peter from it and there remaineth a brown-yellow powder, which dry and keep; it looketh like grinded glass. Take now a common *Regulus* of Antimony made with Salt-peter and Tartar, grind it small and put it into a round glass, which must not be too high, and fasten a head to it. Sublime your *Regulus* in sand by itself without any addition, sweep the sublimate with a feather again into the glass and sublime it again. Repeat this so long till nothing do rise, but [the matter] remain red and fixed in the bottom. Then take this fixed Antimony and put it upon a stone in a cellar and in time it will be dissolved into water, which distil *in Balneo Mariae* until the sixth part only of the water do remain in the glass. Set this in a cold place and there will shoot reddish crystals, which dissolve in rain water. Filter it and draw off the phlegm to a thickness, set it to dry as before and the crystals will shoot white and very pure, like unto Salt peter. This is the Salt of Antimony.

Take these crystals and pour upon them pure distilled Vinegar and they will dissolve in the Vinegar. Then distil the Vinegar, the glass being very close luted, forcing at last the Spirits into the Vinegar and then the Vinegar is prepared. Take this Vinegar and pour it in the prepared brown-yellow powder and set it in some warm place and the Vinegar will draw out the tincture of Antimony, altogether red, within half or quarter of an hour. Pour off this extraction together and set it to digest twenty-eight days *in Balneo Mariae*.

Afterwards distil from it the Vinegar through an Alembick in sand, forcing in the end the oil into another glass, which comes over with many strange and wonderful veins. Rectify this oil in ashes and the rest of the Vinegar, if any be left, will come off and the oil remaineth very sweet and of a pleasant red colour like a Ruby. Thus have you joined the Sulphur with the Salt of Antimony and brought it over like an *Aqua Vitae*, which keep very carefully. Furthermore take again a common *Regulus* of Antimony made with Salt-peter and Tartar and beat it to [a] powder. Then take of strong distilled Vinegar four quarts and a half. Put into it of Sal Armoniack [and] of Salt of Tartar likewise eight ounces (I shall teach how to make it at the end of the directions). Digest this to the evaporation of the Vinegar and mingle with the Salts three parts of Venice Tripoli and distil the Spirit, which is of a singular nature and property.

Pour this Spirit on the pulverised *Regulus* of Antimony and having the glass well luted let it stand in digestion sixteen days; then distil the Spirit from the matter to a dryness and grind four times the weight of filings of steel with the same. Put it into a retort and putting thereto a large receiver full of water, distil it, forcing at last with a strong fire, and the Mercury comes over in fumes and is quickened in the water, which is the true Mercury of Antimony.

Take common Spirit of Vitriol, add a little common water to it and put your filings of steel into it. Let it stand till the filings are dissolved, then pour it off clean and put away the feces. Afterwards distil the Spirit in ashes to a thickness and set the glass in a cold place and there will shoot good Vitriol of Iron, which take, and having first vapoured away the phlegm mingle with it three parts of the powder made of burned potsherds of broken pots, put it into a retort, draw off the phlegm first, then force the Spirit with a strong fire into a proper glass, which rectify to the height and there will remain an oil in the bottom. Pour this oil upon the Mercury made before and draw off the phlegm in hot ashes and the tincture of the *Aqua vitae* remains behind and doth precipitate the Mercury into a fair, high-coloured powder of very great virtues in curing old running sores.

### **The Conjunction Of The Three Principles Sulphur, Salt And Mercury Of Antimony**

Take of this precipitate, welledulcorated with Spirit of Wine, one part and pour on it of the above mentioned sweet oil, three parts, in a phial, so that the phial be not above one half full.

Then seal it hermetically and place it in a philosophical furnace and the precipitate will be dissolved in that continual heat. Open then the glass and continue a strong fire till the matter become a fixed powder and do fix and then the Stone *Ignis* is prepared of which I have written. This Stone is a particular tincture in men's bodies as well as in those of metal[s]. This may be used in many hard and dangerous distempers. Take of this Stone or particular tincture half an ounce, cast it upon twelve ounces and a half of pure Silver or upon as

much Pewter or Lead, let it flow very well for four and twenty hours, then drive it off clean and quart<sup>410</sup> it as tryers and refiners do and you will find in the Silver two ounces and a half of very good Gold and in the Pewter or Lead one ounce upon the cupel.

### **Another Medicine Made Out Of Antimony And Mercury And Of Its Effects In Outward Sores**

Take Hungarian Antimony and sublimed Mercury and grind them well together and distil them through an earthen retort, forcing them at last with the strongest fire imaginable and you will obtain an oil, which separate and keep apart. Put away the quick Mercury, if so there be any; and the Cinnabar you will find in the neck of the retort. But as for the *Caput Mortuum*, grind it small and put it into a new retort and having poured on it the oil, first made warm, distil it again from it. Repeat so often till the *Caput Mortuum* remain behind like ashes and then your oil is prepared.

After this take so much fresh Antimony as first of all the *Caput Mortuum* did weigh, grind it small and put on it the oil, first warmed, and so many times distil<sup>411</sup> as before till the oil come over as red as a Ruby and the *Caput Mortuum* likewise remain like ashes in the bottom of the glass and then the oil is prepared.

### **The Preparation Of The Sublimate For This Work**

Take one pound and a half of Hungarian Vitriol, one pound of common Salt and four ounces of Salt-peter; grind this together and put [with?] one pound of Quicksilver into the bottom of a glass body; place it in sand so that the sand do not come above the matter in the glass; put a head thereupon and give it a convenient fire and the sublimate will stick to the sides of the glass, which is to be used in your work.

Take the above prepared *Aqua vitae*<sup>412</sup> and add to eight ounces of it three ounces of Salt-peter water and distil it out of a coated, glass retort and you will have an ounce of the *Aqua vitae*<sup>412</sup> remain behind fixed. Then put again to the *Aqua vitae*<sup>412</sup> one ounce of fresh Salt-peter water into a retort and distil as before and there will stay more behind. This addition of fresh Salt-peter water to the *Aqua vitae*<sup>412</sup> and<sup>413</sup> distillation out of a coated retort, as has been said before, repeat so often till all remains fixed in the retort.

### **The Salt-Peter Water Is Made Thus**

Take unburned potsherds grinded small and with three part of the same grind one part of purified Salt-peter. Put into the receiver half a pound of water to one pound of Salt-peter and force the Spirits over into it. That which is fixed with this water<sup>414</sup>, put into a glass body and pour upon it the common *Aqua vitae Vitrioli* so that it be four fingers high upon it. Then distil it till the matter become dry. Take out this matter and dry it yet more that the rest of those corrosive Spirits may evaporate, then edulcorate it well with Spirit of Wine and the Medicine is prepared.

### **The Use**

Three or four grains of this Medicine being taken in some good treacle for some days cureth the French pox; there [be] no sore so old and festered but is cured infallibly by it. I have cured with it likewise many spreading, old, running ulcers, as fistulas, cancers, the wolf<sup>415</sup> and the like. The Name of the Lord be praised therefore.

### **The Preparation Of A Medicine Out Of Common Sulphur**

Take common Sulphur and grind it small, then grind with it three parts of calcined Vitriol, put it together into a high cucurbite and sublime it in sand till nothing will sublime more. Take then these flowers, put them into a glass and pour on them a common *Aqua vitae Tartari*, which hath been dissolved in a cellar, so that it swim on the top of its a hand's breadth. Place it in a convenient heat and the Sulphur will open itself in [a] few hours and become transparent red like a Ruby. This being done pour off the extraction into another glass and put to it very good distilled Vinegar and the Sulphur falls to the bottom with a great stink.

Pour off the *Aqua vitae* and edulcorate well the Sulphur and dry it gently. Put this Sulphur again into another glass cucurbite and pour upon it Spirit of Wine, which is prepared with philosophical Tartar, set it in heat for three days and the Spirit of Wine imbibeth again that excellent tincture of the Sulphur. Then pour off the extraction and draw off the Spirit of Wine with a pretty strong fire in sand and there will come over with it a pleasant, sweet smelling *Aqua vitae*. Having done so, rectify the oil in *Balneo Mariae* and draw off the Spirit of Wine gently and the *Aqua vitae Sulphuris* remaineth in the bottom.

### **The Use Of This Medicine**

Six or eight drops of this oil being taken in a spoonful of Wine are good for those that are in a consumption. It is good likewise for coughs, openeth the breast and ulcers of the breast, likewise imposthumes. It relieveth against whatsoever may occasion any putrefaction in a man's body if the use of it be continued for some time.

### **The Preparation Of The Tincture Of Corals**

Take red Corals, break them into pieces and pour on them a common Spirit of Salt and the Corals will be dissolved. This being done, draw off by distillation the Spirit of Salt and edulcorate them well. Then take to one marck<sup>416</sup> of this powder half an ounce of common Sulphur, pulverised, and having mingled it together, reverberate it very gently till all the Sulphur be burned away. Having done so, grind as much Camphor with the Corals and burn the Camphor likewise away. Then edulcorate well the Corals and pour upon them high rectified Spirit of Wine and digest them for eight days and the tincture of the Corals will elevate itself into the Spirit of Wine. Then pour off that which you have extracted and after that draw off the Spirit of Wine from it and there remaineth the tincture of Corals behind in the bottom like a red, fat oil of Olives.

### **The Use Of The Medicine**

Six drops of this tincture given in a spoonful of Wine to those that are bereaved of their senses restoreth them again. This tincture comforteth likewise the brain and strengthens the memory, dispelleth sadness and melancholy, makes light-hearted, breedeth good blood and strengtheneth the heart. It is such a noble Medicine for which we are bound indeed to bless Almighty God.

### **Of The True Solution Of Pearls**

Take very good Verdigris, grind it small and dissolve it in distilled Vinegar; pour off the clean and throw away the feces. Then distil off the Vinegar out of a glass body to a thickness and put it into a cold place and there will shoot from it a fair Vitriol. Put this Vitriol into another glass and pour on it a high rectified Spirit of Wine and dissolve therein the Vitriol very well. Separate the feces from it [and] afterwards distil off likewise the Spirit of Wine to a thickness and set it again in a cold place and the Vitriol shooteth again. Put then the Vitriol into a glass body and draw off by distillation the phlegm *in Balneo Mariae* till the matter becomes dry. Take it out, put it into a glass retort and distil once more with a stronger fire in sand and you will obtain a pleasant Vinegar. Dissolve in this Vinegar as many Pearls as it will dissolve, for this Vinegar worketh very well upon them, dissolveth the substance but not the shells. The Pearls being dissolved, draw off the Vinegar *in Balneo Mariae* till the Pearls be very dry, then take them out and edulcorate them with Rose-water. Put these Pearls thus prepared into a glass body and pour some Spirit of Wine upon them and digest them in [a] gentle heat four and twenty hours and there riseth a pleasant liquor from the Pearls which doth mount and swimmeth upon the Spirit of Wine like an *Aqua vitae* made of Cinnamon. Pour it off together with the Spirit of Wine and keep it.

### **The Use Of This Medicine**

Take of this Spirit of Wine half a spoonful so that four or five drops of the oil may go with it. It comforteth the heart, gives strength to the very marrow and bones [and] cureth swimming in the head and whatsoever may be hurtful to the eyes. [It] dispelleth rheums in the head and the noise in the ears, openeth the passage to hearing and is, moreover, a most precious treasure in many distempers.

### **A Certain Cure Of The Stone**

Recipe. Of common Salt-peter, well purified, one pound and as much of common white Spirit of Vitriol. Pour the Spirit of Vitriol upon the Salt-peter and the Salt-peter will be dissolved together. This being done, distil from thence the Spirit of Vitriol in ashes to a thickness and set it in some cold place and the Salt-peter will shoot again from it. Take two ounces of this Salt-peter and the like quantity of the Salt of Wormwood; pour on them a little of the oil of Sulphur made *per campanam* so that the Salts may be like a poultice. Mix with it likewise one dram of Anniseed oil and as much of white Amber, adding thereto a pound of Canary sugar and mix all these ingredients very well together. Let him that is tormented with the stone take of this powder every day five or six time[s] as much as will lie

upon a point of a knife, twice repeated, and this medicine will work upon the stone and break it and throw it out radically.

### **Of The Soul Or The Sulphur Of Lune Or The Philosopher's Silver**

Take common Salt(-peter) and quick or unslaked Lime, reverberate them together in a wind furnace with the strongest fire, extract again the Salt-peter with warm rain water and coagulate it to dryness; mingle again with it new quick Lime, reverberate it and extract again; repeat this the third time. This being done take Calx of Silver, being after the dissolution in an *Aqua fort* prepared, and mix it with prepared Salt[-peter]; put it into a glass viol, pour on it common *Aqua fort* such as the goldsmiths use, made of Salt-peter and Vitriol, and draw it off by distillation in hot sand. Pour on it some fresh *Aqua fort* and having distilled it likewise, repeat it the third time, giving at last [a] very strong fire, that the matter in the glass may flow very well. Let it cool of itself in the furnace and the Silver will become transparent blue in one piece. Extract this with Vinegar till you can extract no more. Edulcorate that which is extracted with water, that the Salt may be separated from it.

Cohobate Vinegar upon the dry Sulphur till it come over like a Sapphire. Reduce the same Silver into small filings and add to it its weight of Sal-armoniack and sublime it in a glass body and the Sal-armoniack carrieth with it the Sulphur of Lune of a very pleasant sky-colour. Put this sublimate into a dish of glass, edulcorate it well with rain water, first distilled, and the Sal-armoniack will be separated. Then dry the Sulphur of Lune, put it into a little body and pour on it good rectified Spirit of Wine and set it twenty-four hours in heat and the Spirit of Wine doth imbibe the Sulphur of Lune, [a] fine transparent blue, like a Sapphire or Ultramarine, and leaveth some few feces behind, which separate from it.

### **The Use**

Five or six drops of this tincture being taken in Wine doth dispel sad and melancholy thoughts. It preventeth unquiet sleep, cureth those as use to rise and wander up and down in the night and likewise that are lunatics and giveth rest to all such as are restless in the night.

### **The Secret Of The Quick Or Unslaked Lime**

Take good, pure Chalk [and] burn it in a potter's furnace with a very strong fire to bring it to an exact maturity. Then grind it small upon a warm stone and pour on it, in a glass body, Spirit of Wine made with philosophical Tartar that the Chalk become like a thin poultice.

This being done, distil from thence the phlegm to the dryness of the Chalk, pour fresh Spirit of Wine on it and distil it off again. Repeat this six times, then grind the matter small and lay it on a stone in a cellar to dissolve and there will flow in a few days from it a liquor, which, when you have gathered, put it into a retort of

glass and distil it in sand and the phlegm comes over first, which keep apart. After this there cometh a spiritual liquor which is likewise to be kept by itself.

Moreover take crystal stones, pulverise them and grind their weight of live or mineral Sulphur with them. Put then this matter upon a broad, earthen platter, stirring it continually, and burn away the Sulphur from it. Then reverberate it in an open, flaming fire for three hours. This being done, likewise put the matter into a glass and pour the liquor upon it. Take likewise crabs eyes<sup>417</sup>, put them into another glass and pour on them of the same liquor; let it stand pretty hot for fourteen days and nights and there will rise from both a moisture, which pour off together very clean into a little body of glass and rectify it *in Balneo Mariae* and the liquor remaineth behind. Three grains of which, being taken in wine, have wrought very great and admirable effects. This Medicine cureth likewise radically the stone of the bladder and kidneys, both in men and women.

Take this burned Chalk, pour upon it and then draw from it again several times an *Aqua fort* made of Vitriol and Salt-peter. Dissolve it afterwards in a cellar. Distil that which is dissolved into an oil with a strong fire. Digest with this oil a Calx of Lune, opened with *Aqua fort*, for a month. Reduce this Calx by melting down with Salt-peter and Sal armoniack and refine it with Saturn; then separate it and you will have a white, fixed Lune, which lay for a day and a night in an *Aqua fort* and you have good Gold, which endureth all trials. *Laus Deo*.

### **The Preparation Of The Great Philosophic Stone**

Our Stone is made out of its own proper Essence; for its transmuteth other metals into real and true Gold, which Gold must be prepared and become a better Stone. And though nothing of another nature must be used in the preparation of our Stone, which might obstruct its majestic excellency, yet the preparation of it in the beginning cannot be made without means. But observe that, as you will hear afterwards, all corrosives must be washed away from it and separated, so that our Stone may be severed from all poison and be prepared to be the greatest Medicine. Now I will show the work itself.

Take of the very best Gold you can have, one part; of good Hungarian Antimony, six parts; melt these<sup>418</sup> together upon a fire and pour it out into such a pot as the goldsmiths use; when you have poured it out it becometh a *Regulus*. This same *Regulus* must be melted again that the Antimony may be separated from it.

This being done, add to it Mercury and melt it again and cleanse it again. Repeat this the third time and the Gold is purged and purified enough for the beginning of the work. Then beat the Gold very thin as goldsmiths do when they gild and make an amalgam with common Quicksilver, which must be squeezed through a leather. Let the Quicksilver fume away little by little upon a gentle fire, that nothing of it may remain with the Gold and stir it about continually with a small Iron [rod] and the Gold is become subtile so that its water may the better work upon it and open it.

### **The Preparation Of The Water**

Take one part of Salt-peter, well purified, and grind with it the like quantity of Sal-armoniack and half as much of pebbles, very well cleansed and washed. Mingle all these ingredients together and put them into an earthen retort, that the Spirits may not come through and put the same into a distilling furnace. The retort must have a pipe behind and put as large a receiver as you can get to the retort. The receiver must lie in a vessel full of cold water and a wet linen cloth must be put round about it, which you must continually [change] with another wet cloth. Then again so much matter [must be put] into the retort [at intervals] till all is gone into it<sup>419</sup> and then your water is prepared.

Take then of the prepared Calx of Gold one part, put it into a glass body and pour three parts of the above made water upon it and place it in warm ashes and the Gold will dissolve in it; but if it should not altogether be dissolved, pour more fresh water upon it and it will dissolve it all. This being done, pour it out into another glass and let it stand till it become cold and it will let fall some feces, which separate by pouring the water from them to another glass. Set this glass *in Balneo Mariae* and put a head upon it. Let it stand in heat day and night and more feces will settle, which separate from it as before. Close up your glass very well after you have put on the head and lute another glass to the head and let it stand for fourteen days in a gentle heat that the body may be well opened. This being done, increase the fire and distil off the phlegm to a thickness that it remain in the bottom like an *Aqua vitae*. That which hath been distilled pour again into the body, having first made it warm, and lute again the head to it and let it stand to digest a day and night. Then draw off the water again by distillation and pour it again warm, upon it. Repeat this so long till the Gold is come over altogether into a low body with a flat bottom. Put this spiritualised solution of Gold again into a glass and pour on it a considerable quantity of rain water, putting thereto three parts of live Mercury to one of Gold but you must squeeze first the Mercury through a leather, and stir it very well together and you will see many wonderful colours. And if you do repeat this, stirring several times, there will fall an *Amalgama* to the bottom and the water will become clear.

This being done, decant the water and dry gently the *Amalgama*, which, havingedulcorated it very well, put upon a broad, shallow, earthen platter under a cover. Stir it about continually with an Iron wire till all the Quicksilver be fumed away and there will remain upon the earthen [platter] a very fair powder of a purple colour<sup>420</sup>.

### **Afterwards You Must Prepare Your Spirit Of Wine With The Philosophical Tartar In The Manner Following:**

First you are to know that the Tartar of the philosophers, whereby the lock is unopened, is not like unto common Tartar as many do think; but it is another Salt and springeth from one root and is the only Key to open and to dissolve metals and is prepared as followeth. Take ashes of a vine which hath borne grapes that have yielded good wine; make of them with warm water as strong a lee<sup>421</sup> as possibly can be made. When you have a considerable quantity of this lee, boil it

away and coagulate it to a dryness and there remaineth a reddish matter. Put this matter into a reverberating furnace and reverberate it for three days or thereabouts in an open fire, that the flame may play very well upon it and stir it continually till the matter is become white.

Afterwards dissolve this [re]verberated matter in fountain water and let it settle, pour off the clear [liquid] and filter it, that all the feces may be separated and coagulate it in a glass body and you will have a pure, white Salt of Tartar from which a true Spirit is drawn<sup>422</sup>.

Take now high rectified Spirit of Wine, fully freed from its phlegm, [and] put the same into a glass phial with as long a neck as possibly you can get. But first of all put into it your Salt of Tartar and then the Spirit to the supereminency of three fingers. Lute a head to the phial and put thereto another glass, let it stand in a gentle heat, then distil gently off the phlegm, and the Spirit of Tartar is opened by the Spirit of Wine and by reason of their reciprocal, wonderful love it comes over with the Spirit of Wine and is united with it. The remaining feces and some phlegm staying behind with them are to be put away.

This is now the right Spirit of Wine, wherewith you may open that which the lover of Art desireth to know, for it is become penetrant by preparation.

Take now the powder of Gold of a purple colour and having put it into another phial, pour on it your Spirit of Wine. Put it, very close luted, in a gentle heat and it will extract the Sulphur of Gold within twenty-four hours of a high red colour like blood. Having done so [so often] that it doth not yield any tincture more, pour off the extraction very clear into a little glass body. The remainder is a white Calx. Pour upon this Calx the aforesaid Spirit of Wine and let it stand in putrefaction, having the glass well stopped, for fourteen days and nights and the Spirit of Wine will become of a white colour like milk, which pour off clear and pour upon it<sup>423</sup> fresh Spirit of Wine and let it stand a day and [a] night longer and it will be coloured again, but not much. Add this to the first and what remaineth do not dry, but leave it in the glass. Put the white extraction into a little body and distil the phlegm from it till it be reduced to a small quantity.

This being done, put the glass in a cellar and there will shoot from it fair and transparent crystals, which having taken out, put the remainder again in a cellar and you will have more crystals, which put together into a body of glass, for it is the Salt of the Philosophers, and pour half the extraction of the Sulphur of Gold upon them and they will dissolve immediately and melt like butter in hot water. And then distil it together out of a glass body in hot ashes and it will come over together in the form of a red oil, which falls to the bottom and the Spirit of Wine swimmeth upon the top, which separate from it.

This (oil) is the true Potable Gold, not reducible into a body, and my *Phalaia*, whereby I have cured many by the blessing of God, giving but three grains of it in Wine.

The other half of the extraction must be distilled gently *in Balneo Mariae* to a dryness [that] the Spirit of Wine may be separated. Pour on it this Oil of Gold or Potable Gold and it taketh the powder in a moment and becomes of a much higher colour than it was before; and this will dissolve in common Spirit of Wine and other Wine as red as a Ruby, which constantly and wonderfully cureth all such distempers of the body as have their origin from within.

Then take that other part of Mercury of Pure Gold which you have kept and pour all this, being its own oil, upon it and distil by an alembick, but not too strongly; and there comes over some phlegm and the oil doth precipitate its own Mercury and becomes white again, the greenness<sup>424</sup> being lost and gone.

This work being done likewise, get a philosophical egg, which the philosophers call their Heaven and you will find two parts of the oil in weight to one part of the precipitated Mercury. Put then the Mercury into a glass and add the oil of Gold to it, so that one part of the glass may be filled and three parts remain empty. Seal it well as Hermes teacheth and put it into the three-fold furnace so that it standeth not hotter than an egg which is under an hen to be hatched, and the matter will begin to putrefy within a month, and doth become very black which, when it doth appear, it is then certain that the matter is open by putrefaction and you may be glad of the happy beginning. Increase now the fire to the second degree and the blackness will vanish away in time and change into many admirable colours. These colours being gone likewise, increase the fire to the third degree and your glass will look like Silver and the rays will become ponderous. Then, increasing the fire to the fourth degree, the fumes will cease by little and little and your glass will shine as [if] it were beset within with cloth of Gold. Continue this fire and the rays will disappear likewise and there will be no more rays be seen to rise, but you will see your matter lie beneath like a brown oil, which at length being become dry, doth appear like into a Granat<sup>425</sup>, which is both fixed and liquid like wax, penetrant like oil and mighty ponderous.

He that hath obtained this may render thanks to God his Creator, for poverty hath forsaken him, diseases will fly from him and wisdom hath taken possession of him.

Having thus prepared your Medicine, if you intend to multiply it proceed as follows. Take of the prepared powder of Gold of a purple colour, as you have done before, three parts. Add to it of the prepared tincture, one part, in a new Heaven or philosophers' egg. Seal it again hermetically and set it again into the furnace as before and the matter will unite itself and dissolve and be brought to perfection within thirty-one days, which is a month, which otherwise will take up

ten months. Thus you may multiply the Medicine *in infinitum* so that you may perform things which the world will account incredible.

Lastly you must know that this Medicine is a very spiritual and piercing one, which cureth any distempers of this world in all creatures whatsoever. One only grain of it being taken, it penetrateth the whole body like a fume, cleareth out of the body all that is bad and bringeth that that is good in the room of it, reneweth the man and maketh of him, as it were, a new man, which it preserveth without any accidents to his age and the term prefixed by the Most High. *Contra mortem remedium non est.*

This Medicine, being first fermented with other pure Gold, doth likewise tinge many thousand parts of all other metals into very good Gold as I showed in a former process, whereby such Gold likewise becometh such a penetrant Medicine that one part doth tinge and transmute a thousand parts of other metals, and much more beyond belief, into perfect Gold. God be blessed and praised both now and for ever more. Amen.

### **Additional Preparations For A Fuller Declaration Of The Same**

#### **Spirit Of Mercury By Itself Or Mercurial Water**

Put running Mercury into a retort and put to it a receiver, which must stand in a glass with water in it. Distil then, and the Spirit will precipitate itself and is resolved into a water. Pour out this water and put the Mercury which sticketh to the neck of the retort back again into the retort. Distil and rectify till you have brought and reduced it to a water. This spirit of Mercury cureth almost all distempers and doth extract the essence out of minerals and metals.

#### **A Tincture Both Upon Men And Metals**

Take the spiritual Gold of a purple colour, extract its Sulphur with distilled Vinegar and separate the Vinegar again from it that it become a powder. This powder being dissolved in Spirit of Red Mercury, that is Gold, put thereto Salt of Gold and fix it. This is an universal Medicine for sick and diseased bodies of men, likewise it is excellent to exalt metals to the highest degrees.

#### **A Tincture Upon White**

Calcine Silver with Salt and Quicklime and extract its blue Sulphur, which elevate and rectify with Spirit of Wine that it remain a liquor. Dissolve this in the white Spirit of Vitriol and in the Spirit of mineral Mercury.

I do not understand here the red Mercury, but the common, white, mineral Mercury, or rather that [which] is extracted out of Vitriol.

Fix it then, and you have an universal Medicine against all distempers and a tincture which doth tinge Lead, Pewter, Mercury and Copper into Silver.

#### **To Make An Ounce Of Gold Out Of Half An Ounce**

Take Spirit of Salt, rectify it with Spirit of Wine and it become sweetish. Pour this upon the Spiritual Gold of a purple colour and it will extract only the Soul or Sulphur of the Gold, but doth not touch the body of Gold. The Sulphur of Gold doth graduate Silver into Gold, yet no greater quantity of it than there hath been of Gold. The body of Gold must be as white as Silver. Reduce it upon a cupel with Saturn and a little Copper and the white body of Gold doth recover again its colour and property and becometh good Gold.

#### **To Make Mercury Of Gold Or The Philosophical Mercury**

Take the Gold of a purple colour out of which the Sulphur is already extracted, digest it with the following water for a month, then revive it again by driving it through a retort in the neck whereof are to be laid Iron plates. Drive it into a receiver with some water in it and it runneth together and becometh a Quick Mercury of Gold.

#### **The Water Is Made As Followeth**

Take Salt of Urine of a young man that drinketh nothing but Wine and likewise Salt of Tartar and Sal-armoniack, *ana*<sup>426</sup>. Let all this dissolve into a liquor, which rectify with Sprit of Wine that it become very sweet. This is the Arcanum wherewith the body of Gold is reduced into a running Mercury.

#### **To Make The Salt Of Gold**

Pour<sup>427</sup> Gold three times through Antimony, beat it into thin plates and dissolve them in *Aqua Regis*. Dissolve likewise Salt of Tartar in Spirit of Wine and draw off the phlegm that it remain like an oil. With this oil precipitate your Gold and separate again the Salt of Tartar from it by ablutions, then reverberate it fourteen days. Pour upon this Calx of Gold distilled Vinegar; let it boil gently a day and night and the Vinegar doth dissolve the Salt of the reverberated Gold. What remaineth in the bottom undissolved must be reverberated again eight days. Then boil it again in new Vinegar (and) put this afterwards to the first solution.

If anything remaineth behind it must be reverberated eight days more till the body is gone into the Vinegar. Then draw off the Vinegar *in Balneo Mariae* and you have the Salt of Gold in a yellowish powder which cureth all distempers.

#### **Soli Deo Gloria**

#### **To Conclude These Preparations With A Brief Discovery Of The First Tincture, Root Aand Spirit Of Metals And Minerals, How They Are Conceived, Ripened, Brought Forth, Changed And Augmented**

#### **Of The First Tincture, THhe Root Of Metals**

Observe that the tincture which is the root of all metals is a supernatural, flying, fiery Spirit. It hath its sustenance and natural habitation in the earth and water, where it may rest and work. And this Spirit is found in all metals, and more abundant in other metals than Gold; for the Gold is very close, solid and compact by reason of its well digested, ripened and fixed body; therefore it can no more enter into the body than the body doth need. But other metals have not such a fixed body, but their pores are open and dispersed, therefore can the tingeing Spirit abundantly more penetrate and possess them. But because the bodies of other metals are unfixed, the tincture likewise cannot stay with these unfixed bodies, but must go out of them, and [it] being [the case that] the tincture of Gold doth in no other metal abound more than in Iron and Copper, as husband and wife, their bodies are destroyed and the tingeing Spirit from thence [is] expelled, which breedeth much blood in the opened, prepared Gold, and by its feeding doth make it volatile. Therefore when the volatile Gold is filled by its meat and drink, it taketh up its own blood, doth dry it up through its own internal fire with [the] help and addition of a moist fire and is again a conquest, which doth fix, nay produceth the highest fixedness, so that the Gold becometh a high fixed Medicine and cannot make a body again by reason of the superabundant blood, except there be added to it a superfluous body into which this [super] abundant fixed blood doth disperse itself, which joined metallic body is penetrated by the exceeding great heat of the fixed blood of the Lion, like fire, [is] cleansed from all impurity and immediately is ripened to a perfect maturity and fixedness.

I now pass to the birth and to the generation, how the *Archeus* doth show and pour forth its power and displayeth it, by which all metallic and mineral forms are exposed to the view and are made formal, palpable and corporeal through the mineral, incomprehensible, flying, fiery Spirits.

First you are to know that all the metals and minerals of the earth have one only matter and one only mother, by which they in general altogether have received their conception and perfect bodily birth. And this matter, which cometh from the centre, doth divide itself in the beginning into three parts to produce some corporeal thing and a certain form of every metal. These three parts are fed and nourished by the elements in the earth out of its body till they become perfect. But the matter, which hath its original from the centre, is framed by the Stars, wrought by the elements and formed by that which is terrestrial and is a known matter and the true mother of metals and minerals and is such a matter and mother out of which man himself hath been conceived, born, nourished and made corporeal, and may be altogether compared to the Middle World<sup>428</sup>; for whatsoever is in the Great World, that is known likewise in the Little and whatsoever is in the Little World, that is likewise in the Great. And thus what is in the Great and Little World together, that is found in the Middle World, which joineth the Great and Little Worlds and is a Soul, which doth unite and copulate the Spirit with the body. This Soul is compared to water and is indeed a right true water, yet doth it not wet like other water, but it is an heavenly water, found dry in a metallic, liquid substance, and a soul-like water, which loveth all Spirits and

doth unite them with their bodies and bringeth them to a perfect life. Therefore it is certain that the water is a mother of all metals, which, being heated by a warm, aerial fire<sup>429</sup>, as is the Spirit of Sulphur, bringeth life into the terrestrial body through its ripening, wherein the Salt is apparently found, which doth preserve from putrefaction, that nothing may be consumed by corruption. In the beginning and in the birth is wrought first the Quicksilver, which yet lieth open with a subtile coagulation, because there is but little of the Salt communicated to it, whereby it showeth more a spiritual than a corporeal body. Other metals, which are all derived from its essence and have more Salt, which maketh them corporeal, do follow after this. I begin with the Spirit of Mercury.

### **Of The Spirit Of Mercury**

All visible and palpable things are made out of the Spirit of Mercury, which is beyond all the terrestrial things of the whole world, and all things are made out of it and have their original from it. For herein is all to be found that can do all that the Artist doth desire to enquire into. It is the principle to work metals, being made a spiritual Essence, which is a mere Air, and flyeth to and fro without wings and is a moving wind, which, after its expulsion out of its habitation by Vulcan, is driven into its Chaos, into which it entereth again and doth resolve itself into the elements, where it is attracted by the Stars after a magnetical manner, out of love, from whence it went forth and was wrought out before, because it desireth to be united again with its like. But when this Spirit of Mercury can be taken and made corporeal, it doth then resolve itself into a body and becometh a clear, fair and transparent water, which is a true spiritual water and the first Mercurial Root of minerals and metals, spiritual, unperceivable, incombustible, without any commixtion of the terrestrial aquosity. It is that heavenly water of which much hath been written. For by the Spirit of Mercury all metals may be, if need requireth, dissolved, opened and without any corrosive reduced or resolved into their first matter. This Spirit reneweth both men and beast[s] like the Eagle<sup>430</sup>, consumeth whatsoever is bad and produceth a great age to a long life.

To declare further the Essence, matter and form of this Spirit of Mercury, I must tell you that its Essence is Soul-like, its matter spiritual and its form terrestrial, which yet must be understood by some incomprehensible thing<sup>431</sup>.

Touching the beginning of this Spirit of Mercury, this is needless to know because it is of no benefit, nor can it do you any good. But observe that its beginning is supernaturally from Heaven, the Stars and Elements, granted in the beginning of the first Creation to enter further into a terrestrial being. And because this is needless as I have told you, leave that which is heavenly to the Soul and apprehend it by faith. That which is of the Stars, leave likewise alone, because such impressions of the Stars are invisible and incomprehensible. The Elements have already brought forth this Spirit perfect into the World, through the nourishment of it, therefore do not meddle with them either, for no man can make any Element, but the Creator alone; and insist upon thy Spirit already produced, which is both formal and not formal, comprehensible and incomprehensible and

yet doth appear visibly, and you have the first matter, out of which are grown all metals and minerals and is one only thing and such a matter which doth unite itself with the Sulphur of Venus or Copper and is coagulated with the Salt of Mars, so that it becometh one body and a perfect Medicine of all metals, not only to generate [them] in the beginning in the earth, as in the great world<sup>432</sup>, but also by [the] help of a moist fire to change and transmute [them], together with the augmentation, in the little world. Let this not seem strange to you, because the Most High hath thus permitted it and Nature hath wrought it.

But [as to] how the Archaeus worketh further by the Spirit of Mercury in the earth, you are to understand that after the spiritual seed is framed from above by the impression of the Stars and fed and nourished through the Elements, this seed is changed into and is become a mercurial water: as in the beginning the great world<sup>433</sup> likewise was made of nothing<sup>434</sup>; for the Spirit moved upon the water and thus was this cold, waterish and terrestrial creature revived to life by an heavenly warmth<sup>435</sup>. It<sup>436</sup> was in the great world the power and the operation of the Light of Heaven<sup>437</sup>; in the little world likewise, the power of God and the operation by His Divine and Holy Breath<sup>438</sup> to work in the earth. Furthermore the Almighty did grant and ordain means for performing of the same that the creature might get power to work upon another creature<sup>439</sup> and one might help and promote the other for the forming and perfecting of all the works of the Lord. Thus was granted to the earth an influence to generate by the Luminaries of Heaven and likewise an internal heat to warm and to ripen that which was too cold for the earth by reason of its aquosity. And thus to every creature a peculiar Genius [is granted] according to its kind, that so there is raised a subtile, sulphureous steam by the starry heaven, not a common, but another, clarified, cleaned and pure steam, separated from others, which doth unite itself with the mercurial substance, by which warm property in a long time the humidity is dried up by little and little and then the Soul-like property<sup>440</sup>, being joined with it, which giveth the body and balsam of maintenance and worketh before too upon the earth by a spiritual and starry influence. Thus happeneth, then, a generation of metals according to the commixtion of the three principles and according as they take in more or less of these three, so the body is formed. If so be the Spirit of Mercury is directed and formed from above upon animals, then there is produced an animal being<sup>441</sup>, but if it seizeth upon vegetables, a vegetable work is brought forth. And if it falls upon minerals, by reason of its infused nature there will spring thence minerals and metals. Nevertheless everyone is differently wrought, the animals by another form by themselves, the vegetables after a manner proper to themselves and the minerals likewise on another fashion, every one after a singular way. Now I shall faithfully discover how this Spirit of Mercury may be had and obtained, the manner how to prepare it, that it may cure diseases and change and alter all metals of the ignoble kind, as they are generated in the little world by a transmutation and augmentation of their seed.

Take, in the Name of the Lord, red mineral Quicksilver which looketh like Cinnabar and the best mineral Gold that can be gotten. Take an equal quantity of

them both and grind them together before they have been in any fire; pour upon them an oil of Mercury made by itself out of the common, putrefied and sublimed Quicksilver; digest them for a month and you will have an extraction which is more heavenly then terrestrial. Distil gently this extraction *in Balneo Mariae* and the phlegm cometh over and the ponderous oil remaineth in the bottom, which taketh up into itself all metals in a moment. Add to this three times the quantity of Spirit of Wine, circulate it in a pelican till it becometh blood-red and hath recovered an incomparable sweetness. Pour off the Spirit of Wine and add to it fresh Spirit of Wine. Repeat this so long till the whole matter be dissolved into an exceeding sweet and ruby colour[ed], transparent liquor, which mingle afterwards together. Pour it upon white, calcined Tartar and distil it with a strong fire in ashes and the Spirit of Wine remaineth behind with the Tartar, but the Spirit of Mercury cometh over. This Spirit of Mercury being mixed with the Spirit of Sulphur Solis, together with its Salt, whosoever shall bring them over joined and united together, that they may not be separated *in infinitum*, he will have such work (if so be it doth receive its Ferment in a due measure and prefixed term, with Gold, by a solution, and is brought in its proper maturity to a *plusquam* perfection) to which nothing may be compared for the preventing of diseases and poverty. This Spirit of Mercury cureth the dropsy, consumption, gout, stone, French pox and all other lasting sores. It is the only Key to make the corporeal Gold<sup>442</sup> potable.

#### **Of The Spirit Of Copper**

Venus is clothed with a heavenly Sulphur, which doth far exceed the Splendour of the Sun, because there is found much more Sulphur in her than in Gold. But learn what the matter is of the said Sulphur of Gold, which dwelleth and reigneth abundantly in Venus. [It] is a flying and very hot Spirit, which can search and penetrate all, as also digest, ripen and bring to maturity, namely [bring] the imperfect metals into [the] perfect. If you ask how the Spirit of Copper can ripen and bring to perfection other imperfect metals, it being itself, in its body, imperfect and not fixed, I answer that this Spirit cannot have or hold in Copper a fixed body for an habitation; therefore the habitation being burned by the fire the guest goeth out of it likewise and must leave his habitation with impatience, for he dwelleth therein like an hireling. But in the fixed body of Gold he hath a protection that nothing can drive him out without the sentence of a peculiar Judge, because he hath taken possession like an heir and hath taken root in that fixed body [so] that [he] cannot be cast out so easily. The tincture which Venus hath obtained is likewise to be found in Mars, yea much more powerful, higher and more excellent<sup>443</sup> for Mars is the husband, Venus the wife. This tincture is likewise to be found in Verdigris and Vitriol as in a mineral. of which a volume might be writ; and in all things there is found a Sulphur which doth burn and yet another Sulphur which doth not burn, which is a wonderful work. The one is white, the other red in the operating birth, but the right and true Sulphur is incombustible, for it is a mere and true Spirit, out of which is prepared an incombustible oil and [it] is indeed the Sulphur out of which the Sulphur of Gold, out of one and the same root, is made and prepared.

This Sulphur may be very well called and christened the Sulphur of the Wise, because in it is found all wisdom<sup>444</sup>, if you except the Mercurial Spirit, which is to be preferred<sup>445</sup>, and with which it, together with the Salt<sup>446</sup> of Mars<sup>447</sup> must be united through a spiritual copulation<sup>448</sup> and [these] three may be brought to a correspondency and be exalted into one operation<sup>449</sup>.

This Spiritual Sulphur doth likewise and in the same manner derive its original from the Upper Region<sup>450</sup>, as the Spirit of Mercury doth, but with another form and fashion, whereby the Stars do show a separation in fixed and unfixed, in tinged and not tinged things. The tincture doth consist only in the Spirit of Copper and chiefly of its consort<sup>451</sup> and is a mere steam, stinking and of a very ill scent in the beginning. And this must be resolved in a liquid manner, that the stinking, incombustible oil may be prepared out of it. This oil is easily joined with the Spirit of Mercury and do[es] soon take up all metallic bodies, being first prepared according to the account I formerly declared. Venus hath much Sulphur; she hath been, together with Mars, digested and ripened sooner than any other metals, but because they have had but little help from the inconsistent Mercury, being he had no room left him to work harder, by reason of superabundant Sulphur, they could not receive or obtain a melioration of their unfixed bodies. Now I will discover a mystery to you, that Gold, Venus and Mars have in them one and the same Sulphur, one tincture and the same matter of their tincture, which matter of the tincture is a Spirit, a Mist and a Fume, which hath penetrated and doth penetrate all bodies. If you can bring it into captivity and do accuate it with the Spirit which is found in the Salt of Mars and then do join with the same the Spirit of Mercury according to their weight and do separate them from all impurity, that they become sweet and sweet-smelling, without any corrosive, you have then a Medicine to which nothing in the world may be compared. If you ferment this Medicine with the shining Sun you have made an ingress which is penetrant to work and to transmute all metals.

Lastly take notice that the root of the philosophical Sulphur, which is an heavenly Spirit, together with the root of the spiritual, supernatural Mercury and the principle of the supernatural Salt, is in one and is found in one matter, out of which the Stone, which hath been found before me, is made, and not in many things although the Mercury be drawn by itself by all the philosophers and the Sulphur by itself, besides the Salt apart<sup>452</sup>, that so [it may appear that] Mercury is found in one and the Sulphur in one and the Salt in one. Notwithstanding all this do I tell you that this is to be understood of the superfluity, which is found [a]lmost in every one - and particularly in many ways may be used profitably and prepared to a Medicine and [for the] transmutation of metals. But the universal, as the greatest treasure of terrestrial knowledge and wisdom and of all the three principles, is one only thing and is found in one only thing and is drawn out of it, which can reduce all metals into one only thing and is the true Spirit of Mercury and the Soul of Sulphur, joined together with the spiritual Salt, enclosed under one heaven and dwelling in one body; and [it] is the Dragon and the Eagle; it is

the King and the Lion; it is the Spirit and the body, which must tinge the body of Gold to be a Medicine, whereby it getteth abundant power to tinge others its consorts.

Concerning the generation of Copper, observe that Copper is generated out of much Brimstone, but its Mercury and Salt are equal in the same, for there is neither more nor less in quantity of one and the other to be found. Now because the Brimstone doth exceed in quantity the Salt and Mercury, there ariseth from thence a great tingeing redness, which great redness hath so possessed the metal that the Mercury could not perfect its fixedness, that a more fixed body might have been produced out of it. You are further to know that the form of Venus' body is of the same condition that a tree is which hath and doth yield abundance of Gum, as in the pine and fir-tree, with other sorts of trees, which Gum is the Sulphur of the tree, which drives out sometimes this Gum at the sides of it by reason of its too great abundance and because it cannot harbour it all. Such a tree now, that is tinged with so much fatness by Nature and the ripening of the elements, burneth and taketh fire immediately; neither is it heavy and [it] is never so durable as oak and the like hard wood, which is solid and compact and hath not his pores so open<sup>453</sup> as that sort of light wood, that the Brimstone might abundantly reign in it. But therefore hath the oak wood more Mercury and a better Salt than the pine or fir-tree. And such wood is never so much apt to swim upon the water as the fir-tree is, because it is [so] close, solid and compact that the air in it cannot bear it up. The same is to understood of metals, but especially of Gold, which, by reason of its much fixed and well ripened Quicksilver, hath a most solid, compact, close, fixed and invincible body, to which neither fire nor water, neither air nor any putrefaction of the earth can do any hurt because its pores are closed up and the corrupting power of the elements cannot injure it. Which fixedness and solid and compact conjunction do demonstrate its natural ponderosity, which is not to be found or proved in other metals, which may be discerned not only by weighing it in a pair of scales, but you will find it likewise if you put but a scruple of pure Gold upon a hundred pound weight of Quicksilver, it will fall presently to the bottom, whereas all other ponderous metals laid upon Quicksilver swim upon it and do not sink to the bottom because their pores are more largely extended that the air or wind may pass through them to bear them up.

Concerning the Spirit of Venus or Copper in physick, you are, in fine, to observe that it is found very necessary and wholesome in its virtue and efficacy; not only that Spirit that lieth *in primo Ente*, but that Spirit likewise which is found in the last matter. Its virtue, power and operation is such that in the rising of the Mother it is to be preferred before any Medicine whatsoever: also against the falling sickness, the dropsy, the stone. If you have a special care of this Spirit of Copper it will work such wonders both inwardly and outwardly as will be accounted of all incredible and supernatural.

To conclude, the Spirit of Copper is a hot Spirit, penetrant and searching, consuming all the bad humours and phlegm both in men and metals and may justly be accounted the Crown of physick. It is very fiery and piercing,

incombustible yet spiritual and without form and, therefore, is capable, like a Spirit, to further in particular the ignition, digestion and ripening of things without a form.

### **Of The Generation Of Mars, Its Spirit And Tincture**

Mars and Venus have one and the same Spirit and tincture as the Gold and other metals have. Though this Spirit be found in every metal, in some [there is] a greater, in some a smaller quantity. It is undeniable and confessed of all that there are divers men and divers opinions, although men in the beginning are made out of one first matter and generated and born out of one seed, yet there is a manifold difference of their opinions because the operation of the Stars hath occasioned this and not without a cause. For the influence of the Great World worketh the other (namely the difference of opinions) after itself in the Little World, because all the opinions, nature and thoughts, together with the whole complexion of man, do derive their original from the influence of the Stars of Heaven and do show themselves according to the Planets and Stars, where nothing can withstand nor obstruct such an influence because the generation of their perfection is already performed and brought to a period or finished. For example, a man is naturally inclined to study, one hath a mind in Divinity, another for the study of the Law, the third for Physick, the fourth will be a Philosopher. Besides all this, there are many wits that have a natural inclination for mechanical arts, as one turneth a limner, another a goldsmith, this man a shoemaker, that man a tailor, another a carver and so forth. All this happeneth by the influence of the Stars, whereby the imagination is strengthened and founded supernaturally, wherein it resolveth to continue; as we do find if a man hath once taken up a resolution in his mind and laid a foundation upon it, that no man is able to bring or keep him from it, that he should not so obstinately stand upon it, death only excepted, which at last closeth up all. The same is understood of chemists and Alchemists, who, having got once into the secrets of Nature, do not intend to give them over so easily except they have more exactly searched Nature and wholly absorbed<sup>454</sup> and finished the study thereof, which yet is no easy matter. Thus you are likewise to understand of metals that according as the infusion and imagination happeneth from above, so happeneth the form likewise; although metals are altogether called metals and are indeed metals, yet as you have understood by divers opinions of men, which are altogether men out of one matter, there may be manifold and divers metals, of which one hath got an hot and dry, another a cold and moist, another a mixed complexion and nature. Therefore because the metal of Mars hath before others been ordered by a gross Salt in the greatest quantity in its degree, its body is the hardest, most inflexible, strongest and coarsest which Nature hath thus appropriated to it. It containeth the least part of Mercury and little more it hath of Sulphur but the greatest part of Salt; and from this mixture is sprung its corporeal being and [it] is thus born into the world with the help of the elements. Its Spirit is an operation equal to other Spirits, but if the true and right Spirit of Iron can be discerned, I assure you one grain of its Spirit or quintessence, taken and administered in Spirit of Wine, comforteth and strengtheneth a man's heart, mind and courage not to fear his

enemies. It stirreth up a lion-like heart within to fight Venus' battles. If the conjunction of Mars and Venus doth rightly happen in a certain constellation<sup>455</sup>, they have success, victory and conquest both in love and sorrow, in fight and peace and will continue of one mind though the whole world should bear a spleen and enmity against them. This spirit cureth wonderfully all martial distempers.

This Spirit of Iron, being rightly discerned, hath a secret affinity with the Spirit of Copper, that they may be so joined together that there riseth one only matter from them, of one and the same operation, form, substance and being, which will cure the same distempers and transmute the particulars of metals with profit and honour.

But Iron, together with its virtue, ought properly to be considered in the manner following, that it hath a terrestrial body only in its corporeal form, which body may be used to a great many things, to alter the blood, to outward wounds, to a graduation of Silver and inwardly to the constipation of the body, which yet is not always beneficial to use, neither in a man's body inwardly and outwardly, nor yet as concerning metals, because there is no great advantage to be made *per se* without the known right means, which do belong to Nature's secret knowledge. Observe one thing more, that the Loadstone and the true Iron are almost of one and the same nature, even as it is according to a divine, spiritual and elemental sense betwixt the body, its Soul and the Chaos out of which the Soul and Spirit are gone; the body is framed last of all out of this composition.

### **Of The Spirit Of Gold**

If you are desirous to get this golden Loadstone, your prayers must be rightly made to God in true knowledge, contrition, sorrow and true humility for to know and learn the three different worlds, which are subject to human reason<sup>456</sup>, as there is the super-celestial world<sup>457</sup>, wherein the immortal Soul<sup>458</sup> keepeth its seat and residence beside its first original<sup>459</sup> and is by God's creation the first moving sensibility, or the first moving sensible Soul<sup>460</sup> which of a supernatural being hath wrought to a natural life. And this Soul and this Spirit is the root and the first fountain and the first creature existing in the life of anything<sup>461</sup> and the *primum mobile*<sup>462</sup>, which hath been so much controverted by learned men. Observe likewise the second celestial world<sup>463</sup> and take good notice of it for therein do reign the Planets and all the heavenly stars have their course, virtue and power in this heaven and do perform therein their service, for which God that placed them there and do work in this their service by their Spirit [on] both minerals and metals.

Out of these two worlds ariseth yet another different world<sup>464</sup>, where it is found and comprehended what the other two worlds have wrought and produced. Out of the first Super-celestial World is derived the fountain of life and of the Soul; from the second Celestial World doth spring the Light of the Spirit<sup>465</sup> and from the third, the Elemental World, cometh the invincible, heavenly yet sensible fire, by which it digested and ripened that which is comprehensible. These three matters

and substances do generate and bring forth the form of metals, among which Gold hath the pre-eminency because the sidereal and elemental operation hath mellowed and ripened the Mercury in this metal the more substantially to a sufficient and perfect maturity. And as the seed of a man doth fall into the womb and toucheth the *menstruum* which is its earth, [and as this]<sup>466</sup> seed which goeth out of the man into the woman is wrought in both by the Stars and the elements that it may be quite united and nourished by the earth to a generation, so you are likewise to understand that the Soul of metals [is worked upon] which is conceived by an unperceivable, invisible, incomprehensible, abstruse and supernatural, celestial composition, as out of water and air, which are formed out of the Chaos and then further digested and ripened by that heavenly, elemental light and fire of the Sun, whereby the Stars do move the powers, when its heat in the inward parts of the earth, as in the womb, is perceived. For by the warming property of the Stars above, the earth is unlocked and opened that the infused Spirit of the same may yield food and nourishment and be enabled to generate something as metals, herbs, trees and beasts, where every one particularly bringeth with it its seed for a further multiplication and augmentation. And as the conception of a man is spiritual and heavenly, whose Soul and Spirit, by nourishment of the earth in the mother's womb, are formally brought up to a perfection, so likewise it is to be observed and understood in every particular of metals and minerals. But this is the true secret of Gold, namely to instruct and teach you by an example and similitude, whereby the possibility of Nature and its mystery is to found in the manner following. It is probably true that the heavenly light of the Sun is of a fiery property and of a fiery being, which the Most High God, as Creator of Heaven and Earth hath granted to it through an heavenly, constant and fixed Sulphureous Spirit for the preservation of its substance, form and body, which creature, through its swiftness is inflamed and set on fire by the air, which inflammation will never be extinguished as long as the motion doth last and the whole created, visible world doth continue and endure, not in the least diminisheth in its power, because there is no combustible matter extant which might be given to it, whose consumption might cause the decay of that great light of heaven. So is Gold by the superior [counterpart] of its essence<sup>467</sup> thus digested and ripened and is become of such a fixed, invincible nature that nothing at all can hurt it, because the upper fixed Stars have penetrated the lower, that the lower fixed Stars, by reason of their infusion and grant of the upper, need not to give place to their equal because the lower hath received and obtained such a constant fixedness from the upper.<sup>468</sup>

I will add another similitude, according to the manner of philosophers, of the great light of heaven and of that small fire, which, being terrestrial, is here kindled every day and is made to burn before our eyes, because that great light hath a magnetical likeness and an attractive, loving power with that same small fire here upon earth, which is yet without form and impalpable and found only spiritual invincible, insensible and incomprehensible. It is remarkable, as it is proved and demonstrated by experience, that that great light of heaven hath a great love for and beareth an affection and inclination to the little fire, which is terrestrial, by

reason of the Spirit whereby both are agitated and preserved from their utter ruin and destruction. For do but consider that as soon as the air, through [the] great moisture which it hath attracted, conceiveth any corruption, that so through mists and further coagulation and conjunction clouds are generated, the beams of the Sun are hindered and obstructed that the Sun cannot obtain its reflection nor have its due penetrating and searching power; so likewise this little terrestrial fire doth never burn so clear in dark and rainy weather, neither doth it show itself with that gladness in its operation as when the air is fair, pure and clear. The cause is this, for through the obstacle of the moist air the love is hindered that the attractive power, growing sad, cannot exercise its perfect love and operation as it ought to do, for the contrary element, the aquosity, causeth this obstruction. As now the Sun, that heavenly great light, hath a special communion and love with the small terrestrial fire to attract after a magnetic manner, so likewise hath the Sun and Gold a special correspondency and a peculiar attractive power and love together, because the Sun hath wrought the Gold through the three principles, which have their loadstone, and is nearest of all related to the Sun<sup>469</sup> and hath attained to the highest degree, so that the three principles are found most mighty and powerful in the same. Next to it is Gold in its corporeal form, because it is framed out of the three principles, but hath its original and beginning from the heavenly and golden loadstone. This is now the greatest wisdom of this world. In this loadstone is and lieth buried the dissolution and opening of all the minerals and metals, their government as also their matter of the first generation and their power as touching health moreover the coagulation and fixation of metals, together with the operation to cure all diseases. Take a special care of this Key, for it is heavenly, sidereal and elemental, out of which the terrestrial is generated. It is supernatural and natural together and is born out of the Spirit of Mercury, heavenly; out of the Spirit of Sulphur, spiritual; but out of the Spirit of Salt corporeal. Out of this spiritual essence and out of this spiritual matter out of which the Gold first of all is made corporeal into one body, the ancient<sup>470</sup> as well as modern Rosie Crucian philosophers do make potable Gold more substantial than out of Gold itself, which must be made spiritual before the potable Gold can be separated out of it. This Spirit cureth likewise the leprosy [and] the French pox, as being a super-fixed mercurial essence, dryeth up and consumeth the dropsy and all running, open sores, which have afflicted a long time; comforteth the heart and brain; strengtheneth the memory and breedeth good blood.

Thus can the Soul of Gold reduced into water, the Spiritual Essence of Pearls and the Sulphur of Corals, united in one, do such things which to Nature seem otherwise incredible; but because experience confirmeth this truth it is deservedly a cordial in this mortal life to be preferred justly before all other cordials by reason of its wonderful effects. The preparation thereof is this. Take Spirit of Salt and with it extract the Sulphur of Gold. Separate the Oil of Salt from it and rectify the Sulphur of Gold with Spirit of Wine that it may become pleasant without any corrosiveness. Then take the true Oil of Vitriol, made out of Vitriol of Verdigris, dissolve in it Iron; make again a Vitriol out of it and dissolve it again into an Oil or Spirit, which rectify likewise as before with Spirit of Wine. Put them together and

draw off the Spirit of Wine from thence. Dissolve the matter which remaineth dry behind in Spirit of Mercury in a due proportion or weight. Circulate and coagulate it. When it becometh constant and fixed without rising any more, you have then, if you ferment it with prepared Gold, a Medicine to cure diseases and to tinge metals.

### Of The Spirit Of Silver

The Tincture and Spirit of Silver is of a sky-colour, otherwise it is a<sup>471</sup> waterish Spirit, cold and moist and not so hot in its degree as the Spirit which is found in Gold, Iron or Copper; therefore is Silver more phlegmatic than fiery, although it hath been reduced by fire out of its waterish substance unto a coagulation. In the same manner have the stones likewise received their hardness, fixedness and tincture, as by one and the same influence. In a Diamond is found a fixed and coagulated Mercury, therefore this stone is harder and more fixed than other stones and is not to be broken as they are. In a Ruby is found the tincture of Iron or the Sulphur of Iron. In an Emerald, the tincture of Copper<sup>472</sup>. In a Granite<sup>473</sup>, the soul of Lead. In Pewter [is] the tincture which is found in the stone called *Topasius*. Crystal is attributed to common Mercury and in a Sapphire is found the tincture and Sulphur of Silver<sup>474</sup>, yet everything in particular, according to its nature and kind, and in metals likewise according to their form and kind. And when the blue colour is separated and taken away from the Sapphire, then is its garment gone and its body is white like a diamond. Thus when Gold hath lost its Soul, it yieldeth then a white body and a fixed white body of Gold, which is called *Luna fixa* by the searching students and novices in this Art.

What hath been said as concerning the stone called Sapphire, for your instruction you may apply to the better knowledge of the nature of metals, for this blue Spirit is the Sulphur and Soul out of which Silver hath its life as well in the earth as above the earth by Art, and the white tincture of Silver upon white always, in a magnetical form of that one thing and creature, wherein the *primum ens auri* likewise is found. This Spirit of Silver alone containeth that which will perfectly cure and dispel the dropsy, even as the Spirit of Gold and of Mercury can radically cure the consumption so that even the centre itself of the said distemper may not be found.

But the Silver is not so provided in its degree with a hot substance and quality in the veins of the earth, but is subjected to a waterish kind, this fault is to be laid upon the Great Light of Heaven<sup>475</sup>, which by reason of its waterish influence hath planted this quality into the Second Creature<sup>476</sup> and into the second Planet of the earth<sup>477</sup> as into Silver. And though Silver doth carry with it a fixed Mercury or fixed Quicksilver, which is born in it, nevertheless it wanted the hot fixed Sulphur, which might have exactly dried up and consumed the phlegm, which is the cause it hath not obtained a compact body<sup>478</sup>, except it be done afterwards by Art of the lesser World. And because the body is not solid and compact, by reason of its waterish substance, hence are its pores not well stopped up nor consolidated, that it might have a due ponderosity and endure a fight with its enemies. Which

virtues ought altogether to be found in Gold, if so be it must conquer all its foes and endure all the trials without fault.

You are likewise to understand that the first matter of metals must be observed, studied and found out through the discovery of their last matter, which last matter, as there are the absolute and perfect metals, must be divided and separated that it may appear altogether naked to a man's eyes and then there may be learned and known by such a division what the first matter hath been in the beginning, out of which the last matter is made. Observe diligently this Arcanum<sup>479</sup>.

Take the sky-coloured Sulphur of Silver, which hath been extracted out of Silver and rectified by Spirit of Wine; dissolve it according to its weight in the white Spirit of Vitriol and in the sweet scented Spirit of Mercury and coagulate them together through a fixation of fire and you will get the possession of the White Tincture and its Medicine. But if you know the *Primum Mobile* it is then needless, because you may bring the thing to perfection out of one.

#### **Of The Soul And Tincture Of Pewter**

The benign Jupiter is almost of a middle nature amongst all the metals. He is neither too hot nor yet too cold, nor too warm nor too moist. He hath not too much of Mercury nor yet of Salt and of Sulphur there is least of all in him<sup>480</sup>. Pewter is found white in its colour, yet of these three principles one doth exceed the other[s] as it hath been clearly discovered in its division according to the true enquiry into Nature's secrets. Out of this composition and mixture of the three principles is generated and wrought and coagulated into a metal and brought to a maturity of perfection benevolent Jupiter. The Spirit of Jupiter doth protect and preserve from all distempers and diseases incident and hurtful to the liver. Its Spirit is naturally, as for its taste, like unto Honey. Its Mercury being made volatile doth get a venomous quality, for its purgeth vehemently and penetrates with violence. Therefore it is not always good that its unlocked Quicksilver should be thus simply used by itself; but if a correction goeth before, it may be very well used with exceeding great usefulness in those distempers and diseases which are immediately subject to his influence; that is to say, when you have taken away from Zadkiel<sup>481</sup> its venomous volatility and it is placed into a better and more fixed state, which doth resist poison. To conclude, if you do extract out of the benign Jupiter his Salt and Sulphur and make Saturn flow very well together with them, Saturn doth get a fixed body, is purified and becometh clear by them and is a total change and real transmutation of Lead into good Pewter, as you will find it upon a most accurate trial. And though this may seem to you not to be true, yet are you to understand that by reason that the Salt of Jupiter is made more Corporeal only by its Sulphur, it likewise hath received an efficacy and power to penetrate Saturn, as the vilest and most volatile metal, and to bring it to its own substance by making it better and you will really find it to be so.

### Of The Spirit Of Saturn Or Tincture Of Lead

Saturn, to generate his metal, which is Lead, is placed in the Upper Heaven, above all the Stars. But in the lower parts of the earth he doth keep the lowest degree<sup>482</sup>. As the uppermost light of Saturn is mounted to the highest altitude of all the lights of Heaven<sup>483</sup>, so likewise in imitation of the same hath Nature given leave and permitted that his children of the Lower Region have retired themselves by Vulcan to those of their quality according as Saturn hath been moved. For the Upper Light is the cause of it and hath generated an unfixed body of Lead through which go and are drawn open pores, that the Air can have its passage through this Saturnine body and bear itself up. But the fire easily worketh upon and consumeth it because the body is not solid and compact by reason of its unfixedness. This is well to be observed by a serious enquirer into all things because there is a vast difference betwixt fixed and unfixed bodies and then the causes of this fixedness and unfixedness. And though Saturn is of a singular ponderosity before other metals, yet will you observe that when they are poured out together after their conjunction in the melting of them, the other metals will always fall to the bottom, as likewise, it happeneth with other metals by pouring them through Antimony. Whereby it doth appear that other metals have a more solid and compact body than Saturn can raise, because it must give place to other metals, make room for them and yield the victory; for it vanisheth away and is consumed together with those unconstant and unfixed metals. For there are the three grossest qualities of the three principles in Saturn and by reason that its Salt is altogether fluid in comparison to other metals and planets, therefore is likewise its body more fluid, inconstant, unfixed and more volatile than any metallic body.

[As for] how Saturn doth proceed towards his regeneration, you are to know that as common water, through natural cold, by the alteration of the Upper Heaven, is congealed so that it becometh a coagulated ice, so likewise it is demonstrated that Lead is coagulated and made corporeal reason of the great cold which is found in its Salt before any other Salt. The coagulated ice is resolved through warmth and so is the coagulated Lead made fluid by fire. It hath most Mercury in it yet inconstant and volatile; but less of Sulphur and, therefore, according to the small quantity of the same, its cold body cannot be heated; and least of all Salt, but fluid; otherwise the Iron would be more liquid and malleable than Saturn if the Salt alone could impart both the malleableness and fluidity, because Iron doth carry with it more Salt than any other metal. And being there is a difference to be found in these things, you must carefully observe how metals are to be distinguished.

All the philosophers, indeed, besides myself, have writ that the Salt causeth the coagulation and the body of every metal; and this is true; but I shall show by an example how this is to be understood. *Alumen plumosum* is reputed and probably accounted to be a mere Salt, and herein may be compared to Iron, which Salt of the aforesaid *Alumen plumosum* is nevertheless found to be as a

matter and not liquid as Iron. On the contrary Vitriol doth show itself like Salt in a small quantity, yet liquid and open, and therefore its Salt cannot cause so hard a congelation in its appropriated metal as that other Salt doth. Although all Salts of metals are grown out of one root and one seed, yet there is a difference of their three principles to be observed. As one herb differs from the other, and likewise in men and beasts a difference is found as concerning the original of their qualities and their three principles, where one herb has something more of this, another herb more of that kind, which is likewise to be understood of men and beasts. The Soul of Lead is of a sweet quality, as also the Soul of Jupiter, and yet sweeter, so that as for sweetness there is hardly anything comparable to it, being first highly purified by separation, that the pure being very well severed from the impure there may follow a compleat perfection in the operation. Otherwise the Spirit of Lead is naturally cold and dry, therefore I do advise both men and women not to make too much use of it, for it over cooleth human nature, that their seed cannot perfect or perform its natural operation, nor is it good for the spleen and bladder. It doth attract the phlegmatic quality, which breedeth melancholy in men. For Saturn is a governor and such a melancholy one whereby a man is upheld and strengthened in his melancholy. Therefore if its Spirit be used, one melancholy Spirit doth attract the other, whereby a man's body is freed and released from its infused melancholy. Outwardly is the Soul of Saturn very wholesome in all sores and wounds, whether they be old or green, whether they happen by thrusting, cutting or naturally by means incident, so that hardly any other metal will do the like. It is a cooling thing in all hot and swelled members, but to eat away and to lay a foundation for healing in all corrupt and putrefied sores, which have their issuing forth from within, there the noble Venus hath the pre-eminency because Copper is hot in its essence to exiccate and dry up, but Lead, on the contrary, is found to be cold in its essence.

That heavenly light of the Sun is much hotter than the light of the Moon, because the moon is much lesser than the Sun, which doth comprehend the eight[h] part of magnitude in the circle of measuring and dividing. And if the moon should exceed the Sun in this magnitude of the eight[h] part, as the Sun doth exceed the Moon, then all the fruit and whatsoever groweth upon the earth would be spoiled and there would be continual winter and no summer would be found. But the Eternal Creator hath herein wisely prescribed a certain order and law to His creatures, that the Sun should give light by day and the moon by night and thus be serviceable to all creatures.

Those children which are addicted to the influence of Saturn are melancholy, surly, always murmuring, like old, covetous misers, which do not good to their own bodies and are never satisfied. They use their bodies to hard labour, vex and fret themselves with troublesome thoughts and are very seldom so cheerful as to recreate themselves with other people, neither do they care much for natural love of women although handsome.

To sum up all, Saturn is generated out of little Sulphur, little Salt and much immature and gross Mercury, which Mercury is to be accounted like scum or

froth which swimmeth upon the water in comparison to that Mercury which is found in Gold, being of a much hotter degree. Hence it is that the Mercury of Saturn hath not so fresh and so running a life as that which is made out of Gold, because more heat is found in this [latter], to which the running life oweth its original. Therefore it is likewise to be observed in the inferior world of the little Vulcan, in the augmentation and transmutation of metals, what description I have given you of these three principles of Saturn concerning their original quality and complexion.

And everyone is to know that no transmutation of any metal can arise from Saturn by reason of its great cold, except the coagulation of Mercury, [which can be achieved] because the cold Sulphur of Lead can quench and take away the hot, running Spirit of Quicksilver if the process be rightly performed; therefore it is rightly observable that the method be so kept that the theory may agree with the practice and concur in a certain measure and concord. Wherefore you must not altogether reject Saturn, nor vilify and disparage it, for its nature and virtues are but known to a few. For the Stone of the Philosophers hath the first beginning of its heavenly, resplendent tincture only from this metal and by the infusion of this Planet is the Key of Fixedness delivered to it through putrefaction, because that out of the yellow there cannot come any red thing except there be first made at the beginning of the black a white one.

# The 48 Enochian Calls or Keys

in the Enochian Language, Crowley's Phonetic, and Dee's English.

## Guide to the Pronunciation of the Enochian Keys (Phonetic)

All letters are sounded as in English with these exceptions:

|   |        |                 |
|---|--------|-----------------|
| A | ah     | as in "fAther"  |
| C | k      | as in "CAke"    |
| E | eh     | as in "grEy"    |
| I | ee     | as in "fEEt"    |
| O | long o | as in "smOke"   |
| Q | k      | as in "Qabalah" |
| U | long u | as in "fOOl"    |

## The First Key

### *The First Key -- Dee's English*

I rayng ouer you, sayeth the God of Iustice, in powre exalted above the firmaments of wrath: in whose hands the Sonne is as a sword and the Mone as a throwgh thrusting fire: which measureth your garments in the mydst of my vestures, and trussed you together as the palms of my hands: whose seats I garnished with the fire of gathering, and bewtified your garments wth admiration. To whome I made a law to govern the holy ones and deliuered you a rod with the ark of knowledg. Moreouer you lifted vp your voyces and sware [obedience and faith to him that liueth and triumpheth] whose begynning is not, nor ende can not be, which shyneth as a flame in the myddst of your pallace, and rayngneth amongst you as the ballance of righteousnes and truth. Moue, therfore, and shew yorselues: open the Mysteries of your Creation: Be frendely vnto me: for I am the servant of the same yor God, the true wurshipper of the Highest.

### *The First Key -- Enochian*

OI sonf vorsg, goho Iad balt, lansh calz vonpho: sopra z-ol ror i ta Nazpad Graa ta Malprg Ds hol-q Qaa nothoa zimz Od commah ta nobloh zien: Soba thil gnonp prge aldi Od vrbs oboleh grsam Casarm ohorela caba pir Od zonrensg cab erm Iadnah Pilah farzm zurza adna Ds gono Iadpil Ds hom Od toh Soba Ipam lu Ipamis Ds lohoho vep zomd Poamal Od bogpa aai ta piap piamo-i od vaoan ZACARe c-a od ZAMRAM Odo cicle Qaa Zorge, Lap zirido Noco MAD Hoath Iaida.

### *The First Key -- Phonetic*

OI sonuf vaoresaji, gohu IAD Balata, elanusaha caelazod: sobrazod-ol Roray i ta nazodapesad, Giraa ta maelpereji, das hoel-qo qaa notahoa zodimezod, od comemahe ta nobeloha zodien; soba tahil ginonupe pereje aladi, das vaurebes obolehe giresam. Causarem ohorela caba Pire: das zodonureusagi cab: erem Iadanahe. Pilahe farezodem zodenurezoda adana gono Iadapiel das home-tohe: soba ipame lu ipamis: das sobolo vepe zodomeda

poamal, od bogira aai ta piape Piamoel od Vaoan! Zodacare, eca, od zodameranu! odo cicale Qaa; zodoreje, lape zodiredo Noco Mada, Hoathahe I A I D A!

## The Second Key

### *The Second Key -- Dee's English*

Can the wings of the windes vnderstand yor voyces of wunder, O you the second of the first, whome the burning flames haue framed within the depth of my Iaws; whome I haue prepared as Cupps for a Wedding, or as the flowres in their beauty for the Chamber of righteousnes. Stronger are your fete then the barren stone, and mightier are your voices then the manifold windes. For you are become a buylding such as is not, but in the mynde of the All powrefull. Arrise, sayth the First: Move therfore vnto his Servants: Shew your selues in powre: And make me a strong Seething: for I am of him that liueth for euer.

### *The Second Key -- Enochian*

Adgt v-pa-ah zongom fa-a-ip Sald vi-i-v L sobam I-al-prg I-za-zaz pi-adph cas-arma abramg ta talho paracleda Q-ta lora-l-q turbs ooge Baltch Giui chis lused orri Od mi-calp chis bia ozongon Lap noan trof cors tage o-q manin Ia-i-don Torzu gohel ZACAR ca c-no-qod, ZAMRAN micalzo Od ozazm vrelp Lap zir Ioiad.

### *The Second Key -- Phonetic*

Adagita vau-pa-ahe zodonugonu fa-a-ipe salada! Vi-i-vau el! Sobame ial-pereji i-zoda-zodazod pi-adapehe casarema aberameji ta ta-labo paracleda qo-ta lores-el-qo turebesa ooge balatohe! Giui cahisa lusada oreri od micalapape cahisa bia ozodonugonu! lape noanu tarofe coresa tage o-quo maninu IA-I-DON. Torezodu! gohe-el, zodacare eca ca-no-quoda! zodameranu micalazodo od ozodazodame vaurelar; lape zodir IOIAD! Adagita vau-pa-ahe zodonugonu fa-a-ipe salada! Vi-i-vau el! Sobame ial-pereji i-zoda-zodazod pi-adapehe casarema aberameji ta ta-labo paracleda qo-ta lores-el-qo turebesa ooge balatohe! Giui cahisa lusada oreri od micalapape cahisa bia ozodonugonu! lape noanu tarofe coresa tage o-quo maninu IA-I-DON. Torezodu! gohe-el, zodacare eca ca-no-quoda! zodameranu micalazodo od ozodazodame vaurelar; lape zodir IOIAD!

## The Third Key

### *The Third Key -- Dee's English*

Behold, sayeth your god, I am a Circle on whose hands stand 12 Kingdoms: Sis are the seats of Liuing Breath: the rest are as sharp sickles or the horns of death, wherein the Creatures of ye earth are to are not, except myne own hand which slepe and shall ryse. In the first I made you Stuards and placed you in seats 12 of government. giving vnto euery one of you powre successively ouer 456, the true ages of tyme: to the intent that from ye highest vessells and the corners of your governments you might work my powre, powring downe the fires of life and encrease continually on the earth: Thus you are become the skirts of Justice and Truth. In the Name of the same your God, lift vp, I say, your selues. Behold his mercies flourish and Name is become mighty amongst vs. In whome we say: Moue, Descend, and apply your selues vnto vs, as vnto the partakers of the Secret Wisdome of your Creation.

### ***The Third Key -- Enochian***

Micma goho Piad zir com-selh a zien biab Os Lon-doh Norz Chis othil Gigipah vnd-l chis ta-pu-im Q mos-pleh teloch Qui-i-n toltorg chis i chis ge m ozien dst brgda od torzul i li F ol balzarg, od aala Thiln Os ne ta ab dluga vomsarg lonsa cap-mi-ali vors cla homil cocasb fafen izizop od mi i noag de gnetaab vaun na-na-e-el panpir Malpirgi caosg Pild noan vnalah balt od vooan do o-i-ap MAD Goholor gohus amiran Micma Iehusoz ca-ca-com od do-o-a-in noar mi-ca-olz a-ai-om Casarmg gohia ZACAR vniglag od Im-ua-mar pugo plapli ananael Q a an.

### ***The Third Key -- Phonetic***

Micama! goho Pe-IAD! zodir com-selahe azodien biabe os-lon-dohe. Norezoda cahisa otahila Gigipahe; vaunudel-cahisa ta-pu-ime qo-mos-pelehe telocahe; qui-i-inu toltoregi cahisa i cahisaji em ozodien; dasata beregida od toreodul! Ili e-Ol balazodareji, od aala tahilanu-os netaabe: daluga vaomesareji elonusa cape-mi-ali vaoresa CALA homila; cocasabe fafenu izodizodope, od miinoagi de ginetaabe: vaunu na-na-e-el: panupire malapireji caosaji. Pilada noanu vaunalahe balata od-vaoan. Do-o-i-ape mada: goholore, gohus, amiranu! Micama! Yehusozod ca-ca-com, od do-o-a-inu noari micaolazoda a-ai-om. Casarameji gohia: Zodacare! Vaunigilaji! od im-ua-mar pugo pelapeli Ananael Qo-a-an.

## **The Fourth Key**

### ***The Fourth Key -- Dee's English***

I haue set my fete in the sowth and haue loked abowt me, saying, are not the Thunders of encrease numbred 33 which raigne in the Second Angle? vnder whome I haue placed 9639 whome none hath yet numbred but one, in whome the second beginning of things are and wax strong, which allso successively are the number of time: and their powres are as the first 456. Arrise, you Sonns of pleasure, and viset the earth: for I am the Lord your God which is, and liueth. In the name of the Creator, Move and shew yourselues as pleasant deliuerers, That you may praise him amongst the sonnes of men.

### ***The Fourth Key -- Enochian***

Othil lasdi babge od dorpha Gohol G chis ge auauago cormp pd dsonf vi v-di-v Casarmi oali Map m Sobam ag cormpo c-rp-l Casarmg cro od zi chis od vgeg dst ca pi mali chis ca pi ma on Ionshin chis ta lo Cla Torgu Nor quasahi od F caosaga Bagle zi re nai ad Dsi od Apila Do o a ip Q-a-al ZACAR od ZAMRAN Obelisong rest-el aaf Nor-mo-lap.

### ***The Fourth Key -- Phonetic***

Otahil elasadi babaje, od dorepaha gohol: gi-cahisaje auauago coremepe peda, dasonuf vi-vau-di-vau? Casaremi oeli MEAPEME sobame agi coremepo carep-el: casaremeji caro-o-dazodi cahisa od vaugeji; dasata ca-pi-mali cahisa ca-pi-ma-on: od elonusahinu cahisa ta el-o CALAA. Torezodu nor-quasahi od fe-caosaga: Bagile zodir e-na-IAD: das iod apila! Do-o-a-ipe quo-A-AL, zodacare! Zodameranu obelisonugi resat-el aaf nor-mo-lapi!

## **The Fifth Key**

### ***The Fifth Key -- Dee's English***

The mighty sounds have entered in ye 3th Angle and are become as olives in ye olive mownt, looking with gladness upon the earth and dwelling in the brightness of the heavens as continually comforters. unto whom I fastened pillars of gladness 19 and gave them vessels to water the earth with her creatures: and they are the brothers of the first and second and the beginning of their own sea[ts] which [are garnished with continually burning lamps] 69636 whose numbers are as the first, the ends, and ye contents of tyme. Therefore come you and obey your creation: visit vs in peace and comfort: Conclude vs as receivers of your mysteries: for why? Our Lord and Mr is all One.

#### ***The Fifth Key -- Enochian***

Sa pah zimii du-i-v od noas ta-qu-a-nis adroch dorphal Ca osg od faonts peripsol tablior Casarm amipzi na zarth af od dlugar zizop z-lida caosagi tol torg od z-chis e si asch L ta vi u od iaod thild ds peral hubar Pe o al soba cormfa chis ta la vis od Q-co-casb Ca nils od Darbs Q a as Feth-ar-zi od bliora ia-ial ed nas cicles Bagle Ge iad i L.

#### ***The Fifth Key -- Phonetic***

Sapahe zodimii du-i-be, od noasa ta qu-a-nis, adaroche dorepehal caosagi od faonutas peripeso ta-be-liore. Casareme A-me-ipezodi na-zodaretahe AFA; od dalugare zodizodope zodelida caosaji tol-toregi; od zod-cahisa esiasacahe El ta-vi-vau; od iao-d tahlada das hubare PE-O-AL; soba coremeffa cahisa ta Ela Vaulasa od Quo-Co-Casabe. Eca niisa od darebesa quo-a-asa: fetahe-ar-ezodi od beliora: ia-ial eda-nasa cicales; bagile Ge-iad I-ell!

## **The Sixth Key**

#### ***The Sixth Key -- Dee's English***

The spirits of ye 4th Angle are Nine, Mighty in the firmament of waters: whom the first hath planted a torment to the wicked and a garland to the righteous: [g]iving unto them fiery darts to vanne the earth and 7699 continually Workmen whose courses visit with comfort the earth and are in government and continuance as the second and the third. Wherefore harken unto my voyce: I have talked of you and I move you in powre and presence: whose Works shalbe a song of honor and the praise of your God in your Creation.

#### ***The Sixth Key -- Enochian***

Gah s di u chis em micalzo pil zin sobam El harg mir babalon od obloc samvelg dlugar malprg arcaosgi od Acam canal so bol zar f-bliard caosgi od chis a ne tab od miam ta vi v od d Darsar sol peth bi en B ri ta od zacam g mi calzo sob ha hath trian Lu ia he odecrin MAD Q a a on.

#### ***The Sixth Key -- Phonetic***

Gahe sa-div cahisa EM, micalazoda Pil-zodinu, sobam El haraji mir babalonu od obeloce samevelaji, dalagare malapereji ar-caosaji od ACAME canale, sobola zodare fabeliareda caosaji od cahisa aneta-na miame ta Viv od Da. Daresare Sol-petahe-bienu Be-ri-ta od zodacame ji-micalazodo: sob-ha-atahe tarianu luia-he od ecarinu MADA Qu-a-a-on!

## The Seventh Key

### *The Seventh Key -- Dee's English*

The East is a howse of virgins singing praises amongst the flames of first glory wherein the Lord hath opened his mouth: and they are become 28 liuing dwellings in whome the strength of man reioyseth, and they are apparaild wth ornaments of brightnes such as work wonders on all creatures. Whose Kingdomes and continuance are as the Third and Fowrth Strong Towres and places of cumfort, The seats of Mercy and Continuance. O you Servants of Mercy: Moue, Appeare: sing prayes vnto the Creator and be mighty amongst vs. For to this remembrance is given powre and our strength waxeth strong in our Cumforter.

### *The Seventh Key -- Enochian*

R a as isalman para di zod oe cri ni aao ial purgah qui in enay butmon od in oas ni para dial casarmg vgear chirlan od zonac Lu cif tian cors to vaul zirn tol ha mi Soba Londoh od miam chis tad o des vmadea od pibliar Othil rit od miam C no quol Rit ZACAR, ZAMRAN oecrimi Q a dah od o mi ca olz aaiom Bagle pap nor id lugam lonshi od vmplif vgegi Bigliad.

### *The Seventh Key -- Phonetic*

Ra-asa isalamanu para-di-zoda oe-cari-mi aao iala-piregahe Qui-inu. Enai butamonu od inoasa NI pa-ra-diala. Casaremeji ujeare cahirelanu, od zodonace lucifatanu, caresa ta vavale-zodirenu tol-hami. Soba lonudohe od nuame cahisa ta Da o Desa vo-ma-dea od pi-beliare itahila rita od miame ca-ni-quola rita! Zodacare! Zodameranu! Iecarimi Quo-a-dahe od I-mica-ol-zododa aaiome. Bajireje papenore idalugama elonusahi--od umapelifa vau-ge-ji Bijil--IAD!

## The Eighth Key

### *The Eighth Key -- Dee's English*

The Midday, the first, is as the third heaven made of Hiacynet Pillers 26: in whome the Elders are become strong wch I haue prepared for my own righteousnes sayth the Lord: whose long contynuance shall be as bucklers to the stowping Dragon and like vnto the haruest of a Wyddow. How many ar there which remayn in the glorie of the earth, which are, and shall not see death, vntyll this howse fall and the Dragon synck? Come away, for the Thunders haue spoken: Come away, for the Crownes of the Temple and the coat of him that is, was, and shalbe crowned, are diuided. Come, appeare to the terror of the earth and to our comfort and of such as are prepared.

### *The Eighth Key -- Enochian*

Bazmelo i ta pi ripson oln Na za vabh ox casarmg vran Chis vgeg dsa bramig bal to ha goho i ad solamian trian ta lol cis A ba i uo nin od a zi agi er rior Ir gil chis da ds pa a ox bufd Caosgo ds chis odi puran teloah cacrg isalman loncho od Vouina carbaf Niiso Bagle auauaga gohon Niiso bagle momao siaion od mabza Iad o i as mo mar poilp Niis ZAMRAN ci a o fi caosgo od bliors od corsi ta a bra mig.

### *The Eighth Key -- Phonetic*

Bazodemelo i ta pi-ripesonu olanu Na-zodavabebe OX. Casaremeji varanu cahisa vaugeji asa berameji balatoha: goho IAD. Soba miame tarianu ta Iolacis Abaivoninu od azodiajiere riore.

Irejila cahisa da das pa-aox busada Caosago, das cahisa od ipuranu telocahe cacureji oisalamahe lonucaho od Vovina carebaf? NIISO! bagile avavago hohon. NIISO! bagile momao siaionu, od mabezoda IAD oi asa-momare poilape. NIASA! Zodameranu ciaosi caosago od belioresa od coresi ta a beramiji.

## The Ninth Key

### *The Ninth Key -- Dee's English*

A mighty garde of fire wth two edged swords flaming (which haue Viols 8 of Wrath for two tymes and a half: whose wings are of wormwood and of the marrow of salt,) haue stled their feete in the West and are measured with their Ministers 9996. These gather vp the moss of the earth as the rich man doth his threisor: cursed ar they whose iniquities they are in their eyes are milstones greater then the earth, and from their mowthes rune seas of blud: their heds are covered with diamond, and vppon their heds are marble sleus.\* Happie is he on whome they frown not. For why? The God of righteousness reioyseth in them! Come away, and not your Viols, for the tyme is such as requireth cumfort.

### *The Ninth Key -- Enochian*

Mica oli bransg prgel napta ialpor ds brin efafafe P vonpho o l a ni od obza Sobca v pa ah chis tatan od tra nan balye a lar lusda so boln od chis hol q C no quo di cial v nal aldon mom caosgo ta las ollor gnay limlal Amma chiis Sobca madrid z chis ooanoan chiis auiny dril pi caosgin od od butmoni parm zum vi C nila Daziz e thamz a-childao od mirc ozol chis pi di a i Collal VI ci nin a sobam v cim Bagle Iab baltoh chirilan par Niiso od ip ofafafe Bagle acosasb icorsca unig blior.

### *The Ninth Key -- Phonetic*

Micaoli beranusaji perejala napeta ialapore, das barinu efafaje PE vaunupeho olani od obezoda, soba-ca upaahe cahisa tatanu od tarananu balie, alare busada so-bolunu od cahisa hoel-qo ca-no-quodi CIAL. Vaunesa aladonu mom caosago ta iasa olalore ginai limelala. Amema cahisa sobra madarida zod cahisa! Ooa moanu cahisa avini darilapi caosajinu: od butamoni pareme zodumebi canilu. Dazodisa etahamezoda cahisa dao, od mireka ozodola cahisa pidiai Colalala. Ul ci ninu a sabame ucime. Bajile? IAD BALATOHE cahirelanu pare! NIISO! od upe ofafafe; bajile a-cocasahe icoresaka a uniji beliore.

## The Tenth Key

### *The Tenth Key -- Dee's English*

The Thunders of Iudgment and Wrath are numbred and are haborowed in the North in the likenes of an oke, whose branches are Nests 22 of Lamentation and Weeping layd vp for the earth, which burn night and day: and vomit out the heds of scorpions and live sulphur myngled with poyson. These be the Thunders that 5678 tymes in ye 24th part of a moment rore [with a hundred mighty earthquakes and a thousand] tymes as many surges. which rest not neyther know any echoing\* tyme here. One rock bringeth furth 1000, euen as the hart of man doth his thowghts. Wo, Wo, Wo, Wo, Wo, Wo, yea Wo be to the earth! For her iniquitie is, was and shalbe great! Come awaye: but not your noyses.

\* "Any echoing time between."

### ***The Tenth Key -- Enochian***

Coraxo chis cormp od blans Liucal aziazor paeb soba lilonon chis virq op eophan od salbrox cynixir faboan U nal chis Coust ds saox co casg ol oanio yor eors vohim gizyax od math cocasg plo si molui ds pa ge ip larag om droIn matorb cocasb emna L patralx yolci math nomig momons olora gnay angelard Ohio ohio ohio ohio ohio ohio noib ohio caosgon Bagle madrid i zirop chiso drilpa Niiso crip ip nidali.

### ***The Tenth Key -- Phonetic***

Coraxo cahisa coremepe, od belanusa Lucala azodia-zodore paebe Soba iisononu cahisa uirequo OPE copehanu od racalire maasi bajile caosagi; das yalaponu dosiji od basajime; od ox ex dazodisa siatarisa od salaberoxa cynuxire faboanu. Vaunala cahisa conusata das DAOX cocasa ol Oanio yore vohima ol jizodyzoda od eoresa cocasaji pelosi molui das pajeipe, laraji same darolanu matorebe cocasaji emena. El pataralaxa yolaci matabe nomiji mononusa olora jinayo anujelareda. Ohyo! ohyo! ohyo! ohyo! ohyo! ohyo! noibe Ohyo! caosagonu! Bajile madarida i zodiropo cahiso darisapa! NIISO! caripe ipe nidali!

## **The Eleventh Key**

### ***The Eleventh Key -- Dee's English***

The Mighty Seat groaned and they were 5 thunders which flew into the East: and the Egle spake and cryed wth a lowde voyce, Come away: [and they gathered themselues together and became] the howse of death of whome it is measured and it is as they are, whose number is 31. Come away, for I haue prepared for you. Moue therfore, and shew your selues: open the Mysteries of your Creation: be frendely vnto me: for I am the servant of ye same yor God, the true wurshipper of the Highest.

### ***The Eleventh Key -- Enochian***

Ox i ay al holdo od zirom O Coraxo ds zddar ra asy od vab zir comliax od ba hal Niiso salman teloch Casar man holq od ti ta z-chis soba cormf i ga Niisa Bagle abramg noncp ZACARe ca od ZAMRAN odo cicle qaa Zorge lap zirdo noco Mad Hoath Iaida.

### ***The Eleventh Key -- Phonetic***

Oxiayala holado, od zodirome O coraxo das zodiladare raasyo. Od vabezodire cameliaxa od bahala: NIISO! salamanu telocahe! Casaremanu hoel-qo, od ti ta zod cahisa soba coremeffa i ga. NIISA! bagile aberameji nonucape. Zodacare eca od Zodameranu! odo cicale Qaa! Zodoreje, lape zodiredo Noco Mada, hoathahe I A I D A!

## **The Twelfth Key**

### ***The Twelfth Key -- Dee's English***

O you that rayng in the Sowth and are 28, The Lanterns of Sorrow, bynde vp yor girdles and viset vs. Bring down your trayn 3663 that the Lord may be magnified, whose name amongst you is Wrath. Moue, I say, and shew yor selues: open ye Mysteries of yor Creation: be frendely vnto me: for I am the servant of the same yor God, the true wurshipper of the Highest.

### ***The Twelfth Key -- Enochian***

Nonci dsonf Babage od chis ob hubaio tibibp allar atraah od ef drix fafen Mian ar E nay ovof soba do o a in aai i VONPH ZACAR gohus od ZAMRAM odo cicle Qaa Zorge, lap zirdo noco MAD Hoath Iaida.

### ***The Twelfth Key -- Phonetic***

Nonuci dasonuf Babaje od cahisa OB hubaio tibibipe: alalare ataraahe od ef! Darix fafenu MIANU ar Enayo ovof! Soba dooainu aai i VONUPEHE. Zodacare, gohusa, od Zodameranu. Odo cicale Qaa! Zodoreje, lape zodiredo Noco Mada, hoathahe I A I D A!

## **The Thirteenth Key**

### ***The Thirteenth Key -- Dee's English***

O you swords of the Sowth which haue 42 eyes to styr vp the wrath of synn, making men drunken which are empty. Behold the promise of God and his powre which is called amongst you a Bitter Sting. Moue and shew your selues: open the Mysteryes of yor Creation: be frendly vnto me: for I am the servant of ye same yor God, the true wurshipper of the Highest.

### ***The Thirteenth Key -- Enochian***

Napeai Babgen ds brin vx ooaona lring vonph dealim eolis ollog orsba ds chis affa Micma isro MAD od Lonshitox ds ivmd aai GROSB ZACAR od ZAMRAN, odo cicle Qaa, zorge, lap zirdo noco MAD Hoath Iaida.

### ***The Thirteenth Key -- Phonetic***

Napeai Babajehe das berinu VAX ooaona larinuui vonupehe dealime: conisa olalogi oresaha das cahisa afefa. Micama isaro Mada od Lonu-sahi-toxa, das ivaumeda aai Jirosabe. Zodacare od Zodameranu. Odo cicale Qaa! Zodoreje, lape zodiredo Noco Mada, hoathahe I A I D A.

## **The Fourteenth Key**

### ***The Fourteenth Key -- Dee's English***

O you sonns of fury, the doughters of the lust, which sit vppon 24 seats, vexing all creatures of the earth with age, which haue vnder you 1636: behold the Voyce of God, the promys of him which is called amongst you Furye or Extreme Iustice. Moue and shew yor selues: open the Mysteries of yor Creation: be frendly vnto me: for I am the servant of the same your God, the true wurshipper of the Highest.

### ***The Fourteenth Key -- Enochian***

Noromi bagie pasbs oiad ds trint mirc ol thil dods tolham caosgo Ho min ds brin oroch Quar Micma bial oiad a is ro tox dsi vm aai Baltim ZACAR od ZAMRAN odo cicle Qaa, zorge, lap zirdo noco MAD, hoath Iaida.

### ***The Fourteenth Key -- Phonetic***

Noroni bajihie pasahasa Oiada! das tarinuta mireca OL tahila dodasa tolahame caosago Homida: das berinu oroche QUARE: Micama! Bial' Oiad; aisaro toxa das ivame aai Balatima. Zodacare od Zodameranu! Odo cicale Qaa! Zodoreje, lape zodiredo Noco Mada, hoathahe I A I D A.

## **The Fifteenth Key**

### ***The Fifteenth Key -- Dee's English***

O thow the governor of the first flame vnder whose wyngs are 6739 which weaue the earth wth drynes: which knowest the great name Righteousnes and the Seale of Honor. Moue and shew yor selues: open the Mysteries of yor Creation: be frendely vnto me: for I am the servant of the same your God, the true wurshipper of the High[e]st.

### ***The Fifteenth Key -- Enochian***

Ils tabaanu li al prt casarman Vpahi chis darg dso ado caosgi orscor ds omax nonasci Baeouib od emetgis iaiadix ZACAR od ZAMRAN, odo cicle Qaa, zorge, lap zirdo noco MAD, hoath Iaida.

### ***The Fifteenth Key -- Phonetic***

Hasa! tabaanu li-El pereta, casaremanu upaahi cahisa DAREJI; das oado caosaji oresacore: das omata monasaci Baeouibe od emetajisa Iaiadix. Zodacare od Zodameranu! Odo cicale Qaa. Zodoreje, lape zodiredo Noco Mada, hoathahe I A I D A.

## **The Sixteenth Key**

### ***The Sixteenth Key -- Dee's English***

O thow second flame, the howse of Iustice, which hast thy begynning in glory and shalt cumfort the iust: which walkest on the eart[h] with feete 8763 that vnderstand and separate creatures: great art thow in the God of Stretch Furth and Conquere. Moue and shew yor selues: open the Mysteries of yor Creation: be frendely vnto me: for I am the servant of the same your God, the true wurshipper of the Highest.

### ***The Sixteenth Key -- Enochian***

Ils viualprt salman blat ds acro odzi busd od bliorax balit dsin-si caosg lusdan Emod dsom od tli-ob drilpa geh uls MAD zilodarp ZACAR od ZAMRAN odo cicle Qaa, zorge, lap zirdo noco MAD, hoath Iaida.

### ***The Sixteenth Key -- Phonetic***

Ilasa viviala pereta! Salamanu balata, das acaro odazodi busada, od belioraxa balita: das inusi caosaji lusadanu EMODA: das ome od taliobe: darilapa iehe ilasa Mada Zodilodarepe. Zodacare od Zodameranu. Odo cicale Qaa: zodoreje, lape zodiredo Noco Mada, hoathahe I A I D A.

## The Seventeenth Key

### *The Seventeenth Key -- Dee's English*

O thow third flame whose whose wyngs are thorns to styr vp vexation and hast 7336 Lamps Liuing going before the[e], whose God is Wrath in Angre, gyrd vp thy loynes and harken. Moue and shew yor selues: open the Mysteries of yor Creation: be frendely vnto me: for I am the servant of the same your God, the true wurshipper of the Highest.

### *The Seventeenth Key -- Enochian*

Ils do alprt soba vpa ah chis manba zixlay dodshi od brint Taxs hubaro tas tax ylsi, so bai ad I von po vnph Aldon dax il od toatar ZACAR od ZAMRAN odo cicle Qaa zorge lap zirdo Noco MAD hoath Iaida.

### *The Seventeenth Key -- Phonetic*

Ilasa dial pereta! soba vaupaape cahisa nanuba zodixalayo dodasihe od berinuta FAXISA hubaro tasatataxaxa yolasa: soba Iad I Vonupehe o Uonupehe: aladonu dax ila od toatare! Zodacare od Zodameranu! Odo cicale Qaa! Zodoreje, lape zodiredo Noco Mada, hoathahe I A I D A.

## The Eighteenth Key

### *The Eighteenth Key -- Dee's English*

O thow mighty Light and burning flame of cumfort which openest the glory of God to the center of the erth, in whome the Secrets of Truth 6332 haue their abiding, which is called in thy kingdome Ioye and not to be measured: be thow a wyndow of cumfort vnto me. Moue and shew your selues: open the Mysteries of your Creation: be frendely vnto me: for I am the servant of the same your God, the true wurshipper of the Highest.

### *The Eighteenth Key -- Enochian*

Ils Micail-z olprit ial prg Bliors ds odo Cusdir oiad o uo ars caosgo Ca sar mg La iad eran brints cafafam ds iumd a q lo a do hi MOZ od ma of fas Bolp comobliort pambt ZACAR od ZAMRAN odo cicle Qaa zorge lap zirdo Noco MAD, hoath Iaida.

### *The Eighteenth Key -- Phonetic*

Ilasa micalazoda olapireta ialpereji beliore: das odo Busadire Oiad ouoaresa caosago: casaremeji Laiada ERANU berinutasa cafafame das ivemeda aqoso adoho Moz, od maoffasa. Bolape como belioreta pamebeta. Zodacare od Zodameranu! Odo cicale Qaa. Zodoreje, lape zodiredo Noco Mada, hoathahe I A I D A.

## The Call or Key of the Thirty Aethyrs

### *The Thirty Names of the Aethyrs:*

- |        |         |         |         |         |         |
|--------|---------|---------|---------|---------|---------|
| 1. LIL | 6. MAZ  | 11. ICH | 16. LEA | 21. ASP | 26. DES |
| 2. ARN | 7. DEO  | 12. LOE | 17. TAN | 22. LIN | 27. ZAA |
| 3. ZOM | 8. ZID  | 13. ZIM | 18. ZEN | 23. TOR | 28. BAG |
| 4. PAZ | 9. ZIP  | 14. VTA | 19. POP | 24. NIA | 29. RII |
| 5. LAT | 10. ZAX | 15. OXO | 20. CHR | 25. VTI | 30. TEX |

### *The Call or Key of the Thirty Aethyrs -- Dee's English*

O you heuens which dwell in the First Ayre, the mightie in the partes of the Erth, and execute the Iudgment of the Highest! To you it is sayd, Beholde the face of your God, the begynning of cumfort, whose eyes are the brightnes of the hevens: which prouided you for the gouernment of the Erth and her vnspeakable varietie, furnishing you wth a powr vnderstand to dispose all things according to the providence of Him that sitteth on the Holy Throne, and rose vp in the begynning, saying: the Earth let her be gouerned by her parts and let there be diuision in her, that the glory of hir may be allwayes drunken and vexed in it self. Her course, let it ronne wth the hevens, and as a handmayd let her serve them. One season let it confownd an other, and let there be no creature vpon or within her the same: all her members let them differ in their qualities, and let there be no one creature aequall wth an other: the reasonable Creatures of the Erth let them vex and weede out one an other, and the dwelling places let them forget thier names: the work of man, and his pomp, let them be defaced: his buyldings let them become caves for the beasts of the feeld. Confownd her vnderstanding with darknes. For why? It repenteth me I made Man. One while let her be known and an other while a stranger: bycause she is the bed of a Harlot, and the dwelling place of Him that is Faln. O you heuens arrise: the lower heuens vnder neath you, let them serve you! Gouern those that govern: cast down such as fall! Bring furth with those that encrease, and destroy the rotten! No place let it remayne in one number: ad and diminish vntill the stars be numbred!

Arrise, Move, and Appere before the Couenant of his mowth, which he hath sworne vnto vs in his Iustice. Open the Mysteries of your Creation: and make vs partakers of Vndefyled Knowledg.

### *The Call of the Thirty Aethers -- Enochian*

Madriax ds praf {Name of Aether, eg LIL} chis Micaolz saanir caosgo od fisis bal zizras Iaida nonca gohulim Micma adoianu MAD I a od Bliorb sa ba ooaona chis Luciftias peripsol ds abraassa noncf netaa ib caosgi od tilb adphaht dam ploz tooat noncf gmi calzoma L rasd tofglo marb yarry I DOI GO od tor zulp ia o daf gohol caosga ta ba ord saanir od christeos yr poil ti ob I Bus dir tilb noaln pa id orsba od dodrmni zylna El zap tilb parm gi pe rip sax od ta qurlst bo o a pi S L nib m ov cho symp od Christeos Ag tol torn mirc q ti ob I Lel, Tom paombd dilzmo aspian, Od christeos Ag L tor torn parach a symp, Cord ziz dod pal od fifalz L s mnad od fargt bams omaoas Conisbra od auauox tonug Ors cat bl noasmi tab ges Leuith mong vnchi omp tilb ors. Bagle Mo o o ah ol cord ziz L ca pi ma o ix o maxip od ca co casb gsaa Baglen pi i tianta a ba ba lond od faorgt teloc vo v im Ma dri iax tirzu o adriax oro cha aboapri Tabaori priaz ar ta bas. A dr pan cor sta dobix Yol cam pri a zi ar coazior. Od quasb q ting Ripir pa a oxt sa ga cor. vm l od prd zar ca crg A oi ve a e cormpt TORZV ZACAR od ZAMRAN aspt sibi but mona ds surzas tia baltan ODO cicle Qaa Od Ozama plapli Iad na mad.

### *The Call of the Thirty Aethers -- Phonetic*

Madariatza das perifa {LIL} cahisa micaolazoda saanire caosago od fifisa balzodizodarasa Iaida. Nonuca gohulime: Micama odoianu MADA faoda beliorebe, soba ooaona cahisa luciftias peripesol, das aberaasasa nonucafe netaaibe caosaji od tilabe adapehaheta damepelozoda, tooata nonucafe jimicalazodoma larasada tofejilo marebe yareryo IDOIGO;

od torezodulape yaodafe gohola, Caosaga, tabaoreda saanire, od caharisateosa yorepoila tiobela busadire, tilabe noalanu paida oresaba, od dodaremeni zodayolana. Elazodape tilaba paremeji peripesatza, od ta querelesata boapisa. Lanibame oucaho sayomepe, od caharisateosa ajitoltorenu, mireca qo tiobela Iela. Tonu paomebeda dizodalamo asa pianu, od caharisateosa aji-latore-torenu paracahe a sayomepe. Coredazodizoda dodapala od fifalazoda, lasa manada, od faregita bamesa omaoasa. Conisabera od auauotza tonuji oresa; catabela noasami tabejesa leuitahemonuji. Vanucahi omepetilabe oresa! Bagile? Mooobe OL coredazodizoda. El capimao itzomatzipe, od cacocasabe gosaa. Bajilenu pii tianuta a babalanuda, od faoregita teloca uo uime. Madariiatza, torezodu!!! Oadariatza orocaha aboaperi! Tabaori periazoda aretabasa! Adarepanu coresata dobitza! Yolacame periazodi arecoazodiore, od quasabe qotinuji! Ripire paaotzata sagacore! Umela od perdazodare cacareji Aoiveae coremepeta! Torezodu! Zodacare od Zodameranu, asapeta sibesi butamona das surezodasa Tia balatanu. Odo cicale Qaa, od Ozodazodame pelapeli IADANAMADA!





# Tuba Veneris

## The Consecrated Little Book of Black Venus

Est VENUS a Superis mihi datum nomen in Astris  
Incola mox Stygius dum TUBA cantat adest  
Subditus En Dæmon SIGNI virtute gemiscit  
Euge! animi mactus victor ab hoste redis.

TUBA VENERIS  
id est

Vocatus sive Citationes Sex Spirituum sub Veneris  
dominio existentium, ubi docetur Methodus  
perficiendi Sigillum Veneris Eiusque Tubam,  
Circuli, Compositio, Nomina propria Spirituum,  
Eorum Vocatus et Sigilla cum horum præparatione.  
Libri consecratio, Operationis Ritus. Spirituum  
Valedictio cum aliis adhuc pluribus in opere  
observandis.

Ioannes Dee Amatoribus Artis Magicæ S.P.D.

Non de variis Negromanticæ Artis vel definitionibus  
vel Speciebus vel etiam multifaria ejusdem praxi hic  
scribendi nostra intentio Scopusque Libelli nostri est,  
quippe quam plurimi de his quam plurima pauci  
tamen pauca clara ac vera quin potius tum captu tum  
praxi difficillima scripsere volumina. Sed Tuba hic  
tibi canimus Amice Lector! per cujus Sonum Sex  
Veneris Dominio subjecti Spiritum ad choreas

She is VENUS on High, a name given to me by the  
Stars.

Soon to be a Stygian<sup>[5]</sup> sojourner,<sup>[6]</sup> she appears  
when the

HORN<sup>[7]</sup> sounds.

The subjugated Dæmon<sup>[8]</sup> groans under the  
strength of the

SIGN

Well done! As the victor, infused with glory,  
you<sup>[9]</sup> return

from the enemy.

The Horn of Venus  
That is

The Calls<sup>[10]</sup> or the Summonings of the Six Spirits  
ruled by Venus, whereby the Method is taught to  
create the Seal,<sup>[11]</sup> Horn, and Circle of Venus, their  
Arrangement, the proper Names of her Spirits, Their  
Calls and Seals with hours for preparation. The  
consecration of the Book, the Rite of the Working.  
The Dismissal of the Spirit with still other things to  
be observed during the working.

John Dee greets the Lovers of the Art of Magic

It is not our intention or the goal of our little book to  
write about the different Negromantic<sup>[12]</sup> Arts, their  
definitions, subdivisions, methods or even their  
various practices of which Views and Books many  
have already written about. Of these difficult  
volumes, only a few are clear and true, at one  
moment for the understanding, the next moment for  
the actual practice. Here however we sound a Horn

excitantur citantur ad normam et modum à me ipso prout edoctus sum sæpe sæpius exercitatum. Citanti enim tibi Dæmones ante omnia Vocatus Spiritui cuius proprius necesse est. Secus haud quaquam comparebunt quamvis eos per fortes conjurationes ceu efficacia vincula cogi posse non negaverim non tamen sine ingenti labore aut circumstantiis prolixis amplivagus et difficillimis. Si vero hujus Vocatus, id est nominum ac citationum seu vocabulorum priorum, quibus Spiritus ab ipsis Planetarum Angelis advocantur imperantur tibi notitia est nec requisitis reliquis in hoc Libello nostro assignatis carueris mox et sine mora strepitu terrore ac phantasmate omni longe remoto citatos à te Spiritum in forma humana comparere coactos experieris. Scire enim te oportet bonos à Deo teropt. Max. malis præpositos esse Spiritibus ut in illos dominentur; qua propter si à Spiritu bono malo alicui præcipietur quidquam hunc ille competenti suo vocatu vocat jubetque, licet forte in lingua mortalibus nobis haud propria quin imo incognita. Inter Doctores variæ quidem de ea opinionem certitudo autem hactenus nulla. Verum enim vero Creator omnium maximus omni creaturæ certum imposuit Characterem nomenque utpote qui numerat multitudinem Stellarum et omnibus eis nomina vocat. Ψ al.CXLVI. Omnes autem mali Dæmones, quum Angeli Stellæque antecederent fuerint in coelis, nomina Signaque illis à Summo creatore imposita adhuc dum retinent atque per hæc ipsissima illos citare et compellere omnino necessarium est, quo modo etiam bonos Angelos advocare possumus, prout alibi docui et demonstravi. Scientiam hanc præfatam ab antiquis Patribus Israëliticis Chaldeis aliisque pluribus pie exercitam ac hodie dum à piis hominibus practicandam. Exinde enim revelatæ sunt Scientiæ: Magia, Qabala et Negromantia, quæ posterior apud Egyptos, Persas et Arabes non parum floruit, licet execrandum in modum usurpata, depravata lacerata, hominibus per Sacrilega pacta in Dæmoniorum malorum mancipia se se sponte tradentibus quod certe horrendum auditu est. Propter pessimum igitur hunc abusum ab Ecclesia et Secularibus Magistratibus hæc Ars piè est interdicta atque ideo paucissimos idoneos de ejus praxi libros reperire fas est. Tubam ergo hanc noctram studio peculiari adeptam fideliter tibi in bonum tamen finem nequaquam autem in tuum interitum (qui ex soli abusione nanciscitur) communicatam legatamque volumus ut pro bono tui ea utaris et commodo v:g: ad levandos thesauros absconditos ad itinera ad Mercaturam ad Navigationem ad bellum et

for you, Beloved Reader! through whose Sound Six Spirits ruled by Venus will be called to come here and dance, using a method that I myself have practiced several times. In order to call the Dæmons, you must Call the Spirits with the proper name of each. Although I do not wish to disagree that they can be forced to come by means of powerful conjurings or strong chains, but not without great effort and plentiful, long-winded, and difficult circumstances. If you are familiar with this Call, that is, the names and special words with which the Spirits are called and ordered by the Planetary Angels themselves, and if you adhere to the other necessities that are shown in our little Book, and if you have pushed away all phantasmagoric figures, you will perceive that soon and without hesitation, noise, or terrors, the Spirits that you have called will be forced to appear before you in human form. You should know that the good angels of God, the best and most High, are placed above evil spirits so they can rule them; therefore whenever an evil spirit must be ordered to do something, the good spirit calls and orders the evil one with his appropriate call, but he does so with a language that is not typical and is indeed unknown to us mortals. Among the Learned there are indeed different opinions, and at this time no certainty. It is certain, however, that the highest Creator gave all created things a distinct Sign and name, since it is written: "He determines the number of the stars; he gives to all of them their names." Psalm 146.<sup>[13]</sup> Because they were once Angels and Stars in the heavens, all evil Dæmons still have the names and Signs that were given to them by the Great Creator, and therefore it is necessary to call and force them by using the same means by which we can also call the good Angels, as I have shown and taught in other places. This aforementioned Science was practiced in antiquity by the Israelite Patriarchs, the Chaldeans, and many others, and pious people of today still practice it. Therefore these Sciences are revealed: Magic, Kabbala, and Negromancy, which last flourished not a little among the Egyptians, Persians and Arabs, even if it was in an unlawful, distorted and mutilated form, since humans voluntarily delivered themselves into the possession of the evil Dæmons through pacts of Sacrilege, which is certainly horrible to hear. Due to this most shameful misuse, this Art was rightfully forbidden by the Church and Lay Authorities and because of this one finds very few books suited to this practice. Therefore, after we convey and hand over to you our Horn, which we attained with

similia ad quæ Spiritus prodesse tibi et inservire possunt uti. Praxis et experientia satis docebit. Dantur ceteroquin alii adhuc vocatus seu citationes Spirituum quæ fiunt per supremos illorum Principes inter semet ipsos habentes sed hi valde difficulter obediunt haud aliter quam cum ingenti strepitu et in forma maxime terribili comparentes non sine ingenti Operatoris periculo. Hic noster proinde Vocatus Spirituum de quo scripturi sumus Veneri proprius est et ideo à nobis Tuba Veneris nuncupatur siquidem mali Dæmones Septem Planetarum Angelis vix non omnes sunt subjecti qui autem huic inserti sunt Libello sub Veneris duntaxat computantur Dominio ex quo capite Libellus Veneris à nobis fuit intitulatus quin etiam isti Planetæ consecrandus est ad cuius descriptionem jam initium facimus teque ad cuncta diligenter auscultare et attendere monemus. Vale!

Perfectum Scriptumque Londini Anno  
MDLXXX. Pridie Nonis Junij.

*Tubæ Veneris Caput primum  
Quomoda Sigillum sive Character Veneris  
pediciendum*

Primum ad Negromanticam hanc operationem nostram requisitum Sigillum Veneris est quod modo sequenti præparandum. Accipiatur Pars æris Cyprii novi et nunquam usati perficiatur ex eo in magnitudine figuræ paulo post delineatæ Lamina quæ scindi debet secundum Planetæ numerum sibi proprium, id est in sex Angulos: cui deinde instrumento ferreo vel chalybeo nova pariter et munda Character insculpatur fiat autem hoc in die ♀ de nocte in tertia et decima hora à ☉ occasu numeranda. Si unius horæ spatium non suffecerit expectandum est usque ad alteram id est decimam horam in Veneris enim duntaxat fieri licet horis et quidem (quod rursus notendum) in novilunio, quare si una nocte ♀ in duabus præscriptis horis sigillum perfici nequit pari ratione expectandum est usque ad alterum novilunium. Perfectum ex post Sigillum infumetur in ipsissima die et hora ♀.

Fumigium fiat em Speciebus:  
Verbena Puscia et Musco.

Involvatur postea in lintheum novum atque iterum in tempore prædicto Novilunii diei horæque noctu

extraordinary trouble, for a good purpose, and under no circumstances to bring about your destruction (for this occurs only when misused), we want to leave it for your use, e.g. for lifting hidden treasures, for Navigating, Trade, war, and other ways likewise where the Spirit can be of service to you. Practice and experience will teach a lot. There are, moreover, still other calls or summonings of Spirits, who appear by means of their highest Princes who exist among them, but it is very hard to get them to obey, and they appear only with immense noise and racket in an extremely terrible form and not without the highest danger for the Operator. Our Call of the Spirits, about which we will write, belongs to Venus and therefore we call it the Horn of Venus. Not all evil Dæmons are ruled by the Seven Planetary Angels; however, those written about in this book, are counted among those under the rule of Venus, which is why we title it above “The Book of Venus,” since it is also dedicated and consecrated to that Planet whose description we now begin, and we admonish you to listen very carefully and pay close attention. Farewell!

Completed and written in London in the year 1580,  
on the 4th of June.

*The Horn of Venus Chapter One  
How the Seal or Sign of Venus is to made*

The first thing we need for our Negromantic work is the Seal of Venus, which is to be made in the following way: One takes a Piece of new Copper ore and from it makes a Plate the size of the figure drawn below;<sup>[14]</sup> one must cut this [Plate] according to the number appropriate for the Planets, that is, with six Angles: the Character should be engraved using a new and pure iron or steel instrument on the day ♀ in the third or tenth hour of night, counted from the time the ☉ sets. If the span of one hour is not sufficient, one must wait until the next hour, i.e. the tenth hour, since work is only permitted in the hours of Venus (we emphasize again) on the new moon, which is why, if one cannot complete the Seal during one night of ♀ in the two prescribed hours, one must wait in the same way until the next new moon. After it is finished, one consecrates the Seal with smoke on the same day and in the same hour of ♀.

Let the Consecration be done with these Materials:  
Verbane, Myrtle, and Musk.

Afterwards one wraps it in new linen and buries it likewise at the aforementioned time of the day of the

defodiatur in terram penes aquam fluentem  
 effodiatur in subsequenti die et hora ♀ pariter de  
 nocte serveturque pro operationis oportunitate.

New Moon, at night next to a flowing body of water,  
 then unburies it on the following night at the hour of  
 ♀, and preserves it for the opportunity of the work.

*Sigillum Veneris*  
 [The Seal of Venus]

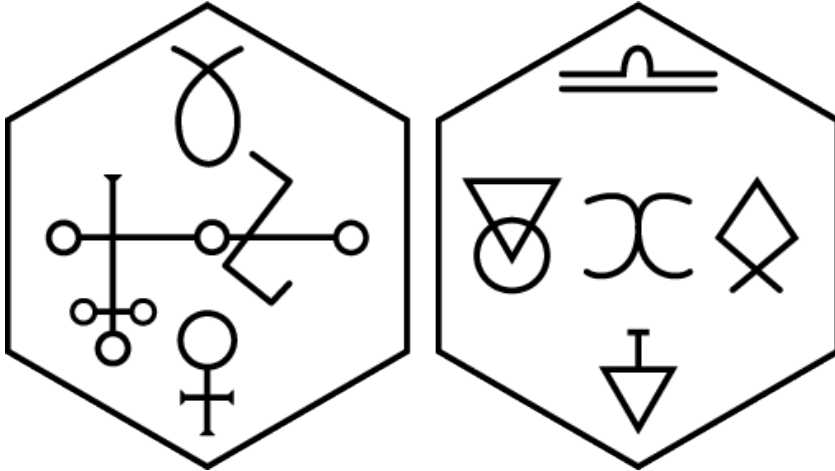

*Caput Secundum.*  
*Quomodo Tuba Veneris sit præparanda.*

Accipiatur Cornu em Tauro vivo dein sumatur  
 Vitriolum in aceto vineo liquefactum cum quo  
 abluatur purgaturque Cornu, quo facto prædicto  
 Instrumento Chalybeo cuius parti insculpanitur  
 Characteres uti in mox sequenti adumbratione  
 extant. Tota autem hæc prædicta Cornu  
 præparatio incluso tempore in quo id ex tauro  
 abripitur, pari ratione ac de Sigillo antecedenter  
 indicatum est in temporibus diebus et horis ♀ fieri  
 debet quod bene notandum est. Infumetur postea  
 ac involvatur in lintheum atque unacum Sigillo ♀  
 infodiatur, effodiatur et in usum conservetur.

*Chapter Two :*  
*How to Make the Horn of Venus*

One takes the Horn<sup>[15]</sup> of a living Bull, then one takes  
 Vitriol dissolved in vinegar, with which one should  
 wash and purify the Horn, after which one carves the  
 Characters as they are represented in the following  
 sketch, into either side of the horn with the  
 aforementioned Steel Instruments. One must make sure  
 that the entire preparation of the Horn, including the  
 time it is torn off from the bull, must also be in the  
 times, days and hours of ♀, just as was done in preparing  
 the Seal. Afterwards, one envelops it in smoke, wraps it  
 in linen, and buries it together with the Seal of ♀, then  
 unburies it again and preserves it for later use.

*Tuba Veneris*  
 [The Horn of Venus]

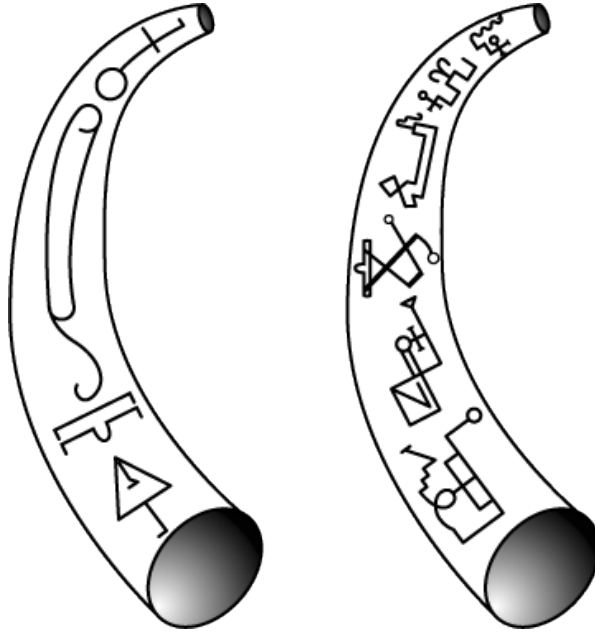

*Caput Tertium  
Quomodo Circulus faciendus*

Antequam ad Spirituum Vocatum seu citationem progrediamur de circuli compositione nobis agendum erit, utpote quo Negromantici omnes in suis semper utantur operationibus per hunc tanquam per fortissimum munimentum contra Dæmonum insidiationes sese tuentes. Compositio autem circulorum multifaria est, aliqui operantes in ædibus eundem perficiunt crete carbonibus et coloribus; nonnulli in sylvis vel biviis exorzisantes faciunt gldio vel certis baculis; Alii vero conficiunt circulum ex pergamento cum inscriptione Divinorum nominum, quem et nos ad nostram operationem elegimus, prout etiam fortunatori hæredi cum cæteris requisitis omnibus jamjam confectum reliquimus, nec non formam ejus et rationem pro libelli nostri ordine et integritate hic adjungimus. Accipiat ergo pergamentum sive charta virginea, scindantur ex eo in latitudine pollicari tres circuli. primus in amplitudine sex pedum reliqui duobus vel tribus digitis angustius, postmodum in præfixis temporibus horisque ♀ Nomina divina cum coloribus inscribantur uti in subsequenti Circuli videntur figura. Circulus postquam confectus infumetur ac defossu in terram hic intermittente ad usum custodiat.

*Chapter Three:  
How to Make the Circle*

Before we talk about how to Call or to Spirit, we must address the arrangement of the circle, from which the Negromancer sets in order everything to be used for the working, in order to protect himself by means of the strongest defenses against the attacks of Dæmons. Different people create the circle various ways. Some, who work in closed buildings, prepare it with chalk, coal or colors. Some, who conjure in forests or at crossroads, create it with a sword or certain staffs; others, however, create the circle out of a parchment upon which the Divine names are inscribed, which is the method which we have chosen for our work, since we have bequeathed the circle to a more fortunate inheritance with all the rest of the objects that have already been made, and we add only the form and method here to our book to order it and to make it whole. One takes thus some parchment or virgin paper, and cuts from this a latitude for three circles, the first [circle] six feet in diameter; the remaining circles two or three fingers in from the first. Soon thereafter the divine Names should be written in color during the prescribed times and hours of ♀, as you can see in the figure of the following circle.<sup>[16]</sup> As soon as the circle is produced, one may consecrate it with smoke, but do not bury it: keep it for use.

*Forma Circuli*

[Shape of the circle]

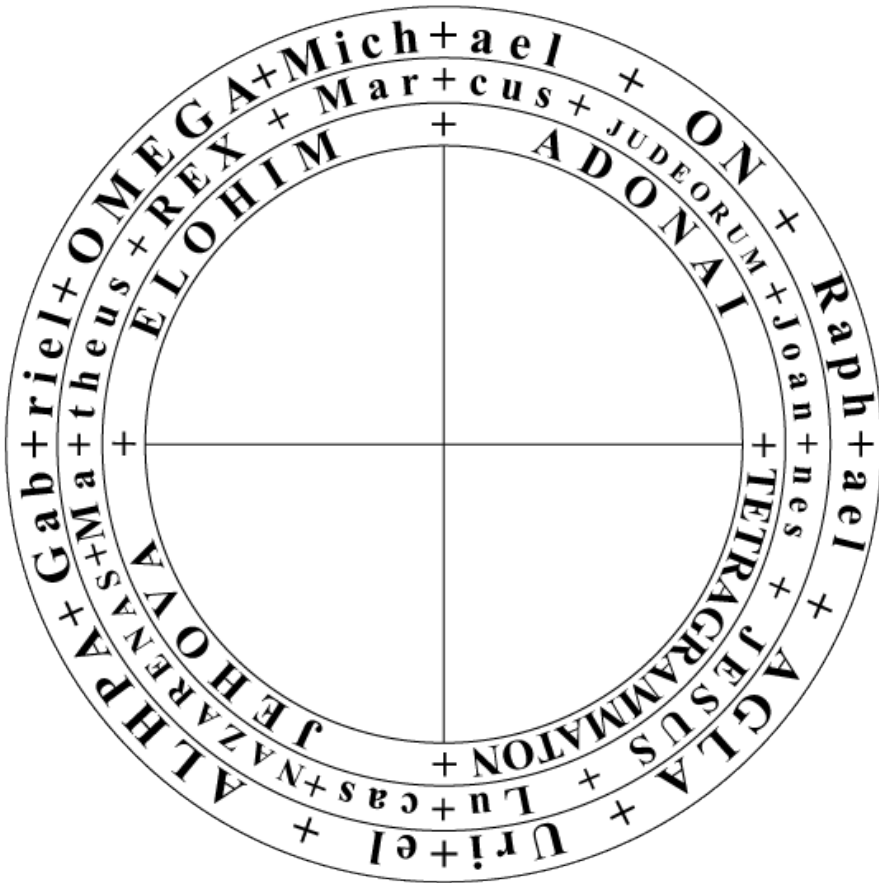

*Caput Quartum*

*Vocatus Spirituum eorum nomina propriis horumque  
signa quomodo sint facienda.*

*Chapter Four*

*How to Call the Spirits, and how to create their  
special names and signs.*

*Nomen primi Spiritus. Mogarip. Sigillum.  
[The name of the first Spirit: Mogarip. The Seal.]*

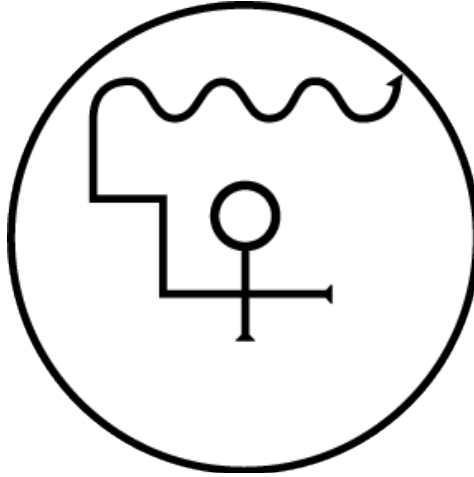

*Vocatus:*

Mogarip! Mogarip! Mogarip! Hamka Temach  
 Algazoth Syrath Amilgos Murzocka Imgat Alaja  
 Amgustaroth Horim Suhaja Mogarip! Mogarip!  
 Mogarip!

*The Call:*

Mogarip! Mogarip! Mogarip! Hamka Temach  
 Algazoth Syrath Amilgos Murzocka Imgat Alaja  
 Amgustaroth Horim Suhaja Mogarip! Mogarip!  
 Mogarip!

*Nomen secundi Spiritus. Amabosar. Sigillum.*  
 [The name of the second Spirit: Amabosar. The Seal.]

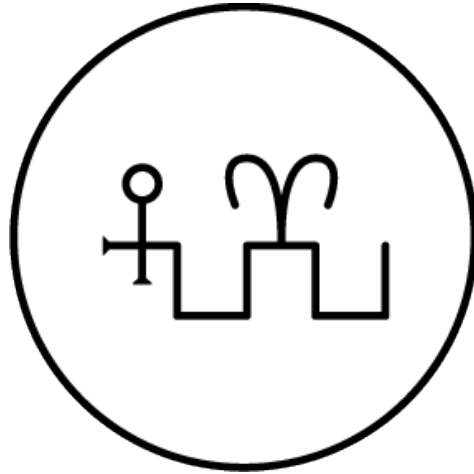

*Vocatus:*

Amabosar! Amabosar! Amabosar! Pharynthos  
 Egayroth Melustaton Castotis Mugos Nachrim  
 Amabosar! Amabosar! Amabosar!

*The Call:*

Amabosar! Amabosar! Amabosar! Pharynthos  
 Egayroth Melustaton Castotis Mugos Nachrim  
 Amabosar! Amabosar! Amabosar!

*Nomen Tertij Spiritus. Alkyzub. Sigillum.*  
 [The name of the third Spirit: Alkyzub. The Seal.]

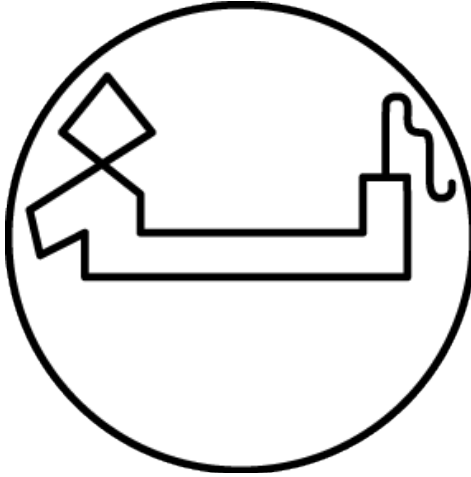

*Vocatus:*

Alkyzub! Alkyzub! Alkyzub! Mergastos Hajagit  
 Agaschar Asmodit Burgum Zephar Largon Cherip  
 Galgadim Uriach Alkyzub! Alkyzub! Alkyzub!

*The Call:*

Alkyzub! Alkyzub! Alkyzub! Mergastos Hajagit  
 Agaschar Asmodit Burgum Zephar Largon Cherip  
 Galgadim Uriach Alkyzub! Alkyzub! Alkyzub!

*Nomen Quarti Spiritus. Belzazel. Sigillum.*  
 [The Name of the Fourth Spirit: Belzazel. The Seal.]

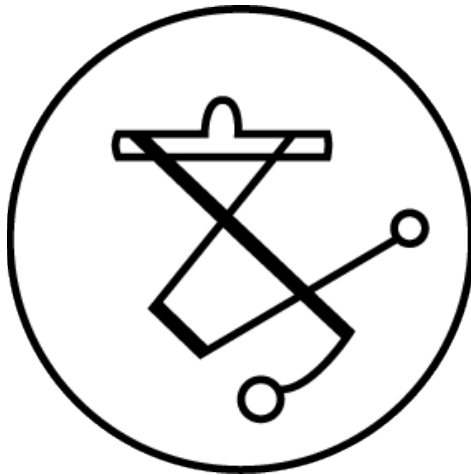

*Vocatus:*

Belzazel! Belzazel! Belzazel! Thittersa Zapkyos  
 Brusiat Algior Soryam Ferozim Abdizoth Mulosin  
 Belzazel! Belzazel! Belzazel!

*The Call:*

Belzazel! Belzazel! Belzazel! Thittersa Zapkyos  
 Brusiat Algior Soryam Ferozim Abdizoth Mulosin  
 Belzazel! Belzazel! Belzazel!

*Nomen Quinti Spiritus: Falkaroth. Sigillum.*  
 [The Name of the Fifth Spirit: Falkaroth. The Seal.]

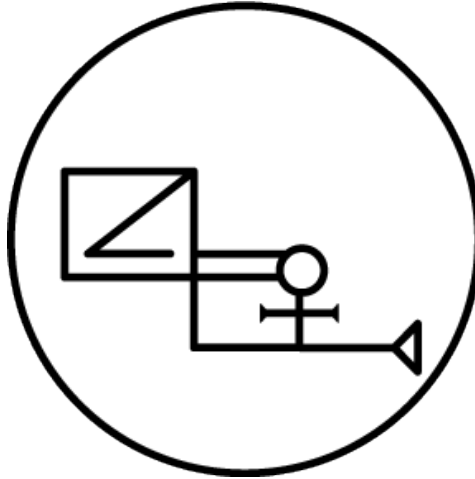

*Vocatus:*

Falkaroth! Falkaroth! Falkaroth! Hymelion Lothaia  
 Estachar Indos Nomirim Hamach Felogon  
 Morgoseos Angar Arastus Falkaroth! Farkaroth!  
 Farkaroth!

*The Call:*

Falkaroth! Falkaroth! Falkaroth! Hymelion Lothaia  
 Estachar Indos Nomirim Hamach Felogon Morgoseos  
 Angar Arastus Falkaroth! Farkaroth! Farkaroth!

*Nomen Sexti Spiritus: Mephgazub. Sigillum.*  
 [The Name of the Sixth Spirit: Mephgazub. The Seal.]

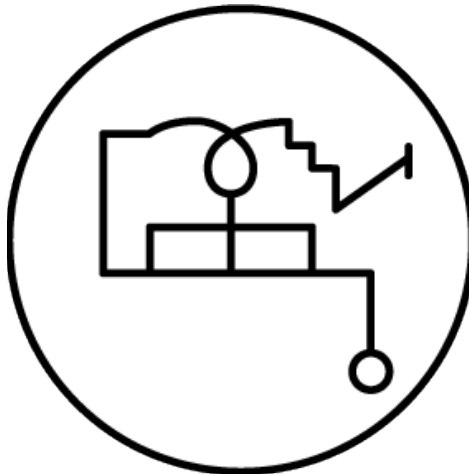

*Vocatus:*

Mephgazub! Mephgazub! Mephgazub!  
 Samanthros Jaramtin Algaphonteos Zapgaton  
 Osachfat Mergaim Hugal Zerastan Alcasatti  
 Mephgazub! Mephgazub! Mephgazub!

*The Call:*

Mephgazub! Mephgazub! Mephgazub! Samanthros  
 Jaramtin Algaphonteos Zapgaton Osachfat Mergaim  
 Hugal Zerastan Alcasatti Mephgazub! Mephgazub!  
 Mephgazub!

*Quomodo hæc Sigilla Spirituum sint facienda*  
 Accipiatur Cera viridis cui misceatur de fuligine,  
 fiant ex ea assulæ rotundæ inseranturque in eas  
 instrumento chalybeo Sigillum hujusce Spiritus  
 qui citari intenditur. fiant hæc sicut cætera

*How to make the Seals of the Spirits*

One takes green Wax, to which one mixes soot, makes  
 from this round pieces and, with steel instruments, cuts  
 into them the Seal of that Spirit one wishes to invoke.  
 Let these Seals be consecrated with smoke in the same

antedicta simili ratione in tempore die et hora ♀  
suffitus cum defossu hic intermittatur verum ad  
opus custodiatur.

*Quomodo Libellus iste sit consecrandus.*

Libellus (cui Spirituum nomina et Vocatus  
inscripti sunt) antecederet consecratur necesse  
est: uti nimirum antiqui fecerunt Magi qui  
similium librorum consecrationem ita instituere ut  
aperiendo duntaxat librum spiritus max  
comparere coëgissent, quod tamen nobis nimium  
videtur periculosum præsertim si talis liber  
infortuite in manus hominum hanc artem penitus  
ignorantium incidat. Quare libellum nostrum  
sequenti consecrare libuit modo. Fiat Libellus ex  
Pergamento cui imprimis insignatur Character ♀ et  
si libet Imago quædam Planetæ hujus figuram  
repræsentans cum ♀ Signo super Caput ejus.  
Libellus intituletur:

*Libellus Veneri nigræ Sacer.*

Ante Vocatum Spirituum scribatur in Rubrica  
Tuba Veneris ad Normam hujus nostri Libelli, qui  
â me ipso consecratus atque cum reliquis omnibus  
appertinentiis posteritati relictus est, si secus  
fortuna hæc omnia tibi ad manus decreverit.  
Integer proinde libellus in sæpe dictis temporibus  
conscribi debet ad quod ulterius requiritur penna  
ex columba atque attramentum calcanto  
compositum et a nemine usatum etiam viridi  
rubeoque colore pro libitu uti potest, nam hi  
colores Planetæ nostro omnino grati sunt. Libellus  
postquam compositus et conscriptus est  
infumicetur. dein accipiatur aqua Vitrioli cum qua  
manus impleatur et liber bapticetur dicendo.

Veneri nigrum te Sacro libellum  
Veneris esto Tuba tibi nomen  
incolis tremena que sitque bene notum  
Omnibus Orci.

O Magne Princeps Anaël Olympi!  
Te rogo supplex robora Volumentuo  
qui perenni semper honori  
fonte lavatur.

Veneris horis Dæmon ut inscriptus  
advolet velox hæc si Tuba cantat  
qua volo præstet, faciat invitus.  
Placidus adsta!

Hoc facto rursus Libellus infumetur atque in  
pannum vel viridum vel rubrum involvetur,  
subdatur supert terram cum cæteris rebus et in

way as the others aforementioned in the time, by the  
day and in the hour of ♀, but do not bury them: rather,  
preserve them for the Work.

*How to consecrate the Book*

It is necessary to consecrate the Book (in which the  
names and Calls of the Spirits are written) before using  
it, just as the old Magi did, whose consecrations forced  
spirits to appear in similar books; however, for us this  
practice is all too dangerous, particularly if such a book  
infortuitously fell into the hands of people completely  
unacquainted in this art. Therefore we prefer to  
consecrate our book the following way: Let the Book be  
made from Parchment, with the symbol of ♀ and, if one  
wills, an Image of this Planet, whose figure is  
represented with ♀ over its Head. The Book should be  
called:

*The Consecrated Book of the dark Venus<sup>[17]</sup>*

Before the Call of the Spirits one should write “The  
Horn of Venus” in Red, as is Standard in our Book,  
which was consecrated by me myself and that will be  
left for future generations with all of the rest of the  
things that belong to it, just as fate has put all of this  
into your hands. This book must be written therefore  
completely in the times of Venus often mentioned  
already, with the feather of a dove, copper vitriol water,  
and virgin ink. Green and red can be used as desired,  
because Venus welcomes these colors. After the book is  
produced and written, one envelopes it with smoke.  
Then, taking the Vitriol water, one fills the hand and  
baptizes the book by saying:

To dark Venus I consecrate you, Sacred Book.  
Horn of Venus is your name  
Whose power is well-known  
To all the sojourners in the underworld.

Oh Anael, Great Olympic Prince!  
I ask you humbly, strengthen this Volume,  
Washed in your spring to eternal honor.

May the Dæmon inscribed within it  
Come quickly in the hours of Venus,  
If this Horn sounds  
And carry out what I want, even if he is unwilling.  
Gently assist me!

As soon as this is done, one should once again envelop  
the Book in smoke and wrap it in a green or red cloth,  
and then bury it with the rest of the things under the

tempore præscripto effodiatur et pro usu conservetur.

#### Quomodo operatio instituenda sit

Si omnia hæc antedicta tandem rite præparata promptaque ad manus fuerint atque operator se se ipsum satis probaverit præparaveritque idoneum et animosum (pro uti id imperterritum magnanimumque omnino desiderat virum) accedat in eodem sæpe indicato tempore hora et nocte ♀ locum ab omni hominum perturbatione securum vel in ædibus vel melius in Sylvia biviisque absitis atque desertis, disponat ibi circulum et suspendat Sigillum ♀ super collum, faciat fumigium et incipiat citare Spiritum ex numero assignato a se electum. Totum autem Votatum per ♀ Tubam pronunciet vocetque Spiritum suo nomine tum ab initia citationis tum in fine sed semper cum aliqua pausa.

Advenientem Spiritum salutet modo sequenti:

Salve nobilis ac obediens Spiritus (nominetur hic Spiritus suo nomine). Impero tibi per tremendum nomen Adonai et per hoc Sigillum (:monstret Spiritui Sigillum:) Angeli Anaëlis Principis Regentis Planetæ Veneris ut quietem te exhibeas et tranquillum atque in omnibus quæ tibi mandaturus sum voluntatem meam adimpleas. Hoc tibi iterato præcipio per Deum Patrem Filium et Spiritum Sanctum et per Triumphatorem Dominum Jesum Christum qui venturus est judicare seculum per ignem.

Post hæc Spiritus Magistrum interragabit quare fuerit citatus, quidnam præcipiat? et desideret atque hoc Magister clare et distincte denominet. ubi notandum quad si Spiritum in aliquibus pertinaces sese ostenderent, accipiatur Sigillum ♀, detur super ignem vel carbores cum quibus fumigium factum est, vel si fumigio non utatur (sicut etiam adeo necessarium non est) porrigatur Sigillum super candelam ardentem ut fiat calidum et imponatur super illud Sigillum istius Spiritus qui citatur per hoc enim enormiter cruciantur Spiritus et rogabunt magistrum ut cesset illos tormentare et non amplius resistant adimplere ejus voluntatem. Non tamen in petitionibus et desideriis Magister nimium excedat, suaserim ne forte Divini Numinis iram provocet; nec inconstantem astutis se monstret spiritibus aut vaticillantem nec minus condiciones ab iis proponendas acceptet. Sed animo forti ac constanti petitionibus à se Spiritibus semel propositis insistat et Spirituum forte simultaneas

earth and at the time prescribed before, unbury it, and store it for use.

#### How to undertake the working

When all of these aforementioned things are finally properly prepared and ready and the operator deems himself suitable and brave enough and has prepared himself (since this requires an absolutely unfrightened and courageous man), he should go during the same oft-mentioned time, hour, and night of ♀ to a safe place free from all human disturbances, either in a building, or better in a Forest or at a isolated and deserted crossroads. There he may spread out the circle and place the Seal of ♀ around his neck. Then he should kindle the fire and begin to invoke one of the spirits he selected from the indicated number. He should speak the entire Call through the Horn of ♀, and he should summon the Spirit by naming it once at the beginning and again at the end, but always with distinct pauses.

He should Greet the Spirit in this way:

“Hail to you, noble and obedient Spirit (here one addresses the Spirit by its name). I order you, in the powerful name of *Adonai* and with this Seal (show the Spirit’s Seal) of the Angel Anael, the Supreme Regent of the Planet Venus, to calmly and peacefully behave and fulfill my will in all things that I instruct you to do. This I command you moreover by God the Father, the Son, and the Holy Ghost, and by the Triumphant Lord Jesus Christ, who will come to judge the world through fire.”

After this the Spirit will ask the Master why he has been summoned and what the master wishes and commands. And this the Master should then clearly and distinctly state. If the spirit shows himself in any way to be uncooperative, one must be sure to take the Seal of Venus and place it over the fire or coal with which the censer was made, or if one is not using a censer (since using one is not absolutely necessary), one may hold the Seal over a burning candle so that it becomes warm and then place it upon the summoned spirit. When one does this, spirits are terribly pained and they beg the master to stop tormenting them and they become no longer resistant to fulfilling his will. Surely I advise that the Master not overstep the mark too much with his demands and wishes and in so doing provoke Divine wrath, nor vacillate and show himself inconstant to the sly spirits, or even worse, accept conditions that they suggest to him. But rather, with a brave and firm mind, he should insist upon the requests he has expressed to the Spirits and he should regard their threats and protestations of feigned difficulties to be empty

difficultates vel etiam minas nauci floccique faciat secus Domini sui in Spiritus frustraretur. Non minus cavendum est, ne Spirituum assistentia pro perpetrands impiis ac sceleratis facinoribus utatur ad quod quidem eo promptiores se se ostenderent Spiritus: verum sic summum sane anima pateretur detrimentum nam dum suum in Dæmones vellet exercere Dominium animam suam in horrendum illorum traderet mancipatum. Quare paucis rursum de omni abusu artis hujus cunctos et singulos fideliter dehortamur. Quod si itaque Spiritus mandata seu voluntatem Magistri adimpleverint licententur modo sequenti:

*Valedictio Spirituum.*

Hæc fit sicut Vocatus per Tubam ♀ hisce verbis: Norcados Fenoram Anosiren (vocetur hic Spiritus suo nomine semel et pergatur) Opareliim Amosan Zezaphilos Aspairath Anthyras Zyriffon. His auditis Spiritum mox fient invisibiles et magistro facta pro libitu benedictione e Circulo egredi est licitum.

*Quæ ulterius adhuc in operatione observanda sunt.*

Si cum sociis fiat experimentum Ille tantum unicus loquatur Spiritibus, qui Magistrum agit, et illos advocat, reliqui omnes silentium observent. Quod si Spiritus ad adferendum Thesauros et nummos compellantur sic pecuniis vel Thesauro imponi debet, Sigillum ♀ ex post evacuetur Thesaurus ex vasibus suis et in aliud vas novum prius perfumatum et benedictum transferatur. Hisce igitur libello nostro finem imponimus. Tu vero amice Lector! de ejus abusu cave quæ hic scripta sunt bene perpende ne quid obliviscaris attendas et si quid agis prudenter agas atque animo imperterrito et constanti perficias et magno tibi erit utilitati et solatio. Ast unicum adhuc restat te admoneamus ut in bono operis successu pauperum quam optime benefaciendo sis memor. Et sic tum in hac tum in altera vita beatus eris at propitius erit omnibus nobis ille qui venturus est judicare vivos et mortuos cujus Regni non erit Finis.

nothings, otherwise he will lose his Rule over these Spirits. No less must one guard himself from using the help of Spirits to carry out godless and criminal deeds which the Spirits will show themselves even more eager to do: indeed, the soul would certainly suffer the greatest damage [if it behaved so] since while he considers himself to be exerting his power over the demons, he would actually be delivering his soul into the terrible servitude of the demons. Therefore we sincerely advise once more against all and every single misuse of this art. When the Spirits have fulfilled the commands or will of the Master, they should be dismissed in the following way:

*The Dismissal of the Spirit.*

Speaking as before through the Horn of ♀, say these words: "Norcados Fenoram Anosiren (here one should call the spirit once by his name and continue) Oparechim Amosan Zezaphilos Aspairath Anthyras Zyriffon." When they have heard these words, the Spirits will immediately become invisible, and the master may leave the Circle after he has spoken whatever benediction he wants.

*Other things that should be paid attention to during the work.*

If the experiment is carried out with other people present, only one person, who acts as Master and does the Calls, should speak with the Spirits. All others should remain silent. If the Spirits are forced to bring treasures or coins, one must place the Seal of ♀ on the treasure and afterwards empty the treasure out of its containers and transfer it into a new container that has previously been perfumed and consecrated. Thus with these bits of advice we end our little book: Guard yourself, beloved Reader, from its misuse; think carefully about the things written here; make sure that you have not forgotten anything; and whenever you do something, make sure that you behaved wisely and carry it out with an unfrightened and firm mind; and great benefit and comfort will result. One thing still remains that we must remind you about, and that is that should you have a great success with the work, the best thing to do is to remember the poor through charitable works. And thus you will be happy in this life as well as in the next, and he will be merciful to us all, who will come to judge the living and the dead, whose Kingdom will have no End.

**Notes**

[1] Dee, John. 1990. *Das Büchlein der Venus* ("Libellus Veneris Nigro Sacer"): eine magische Handschrift

des 16. Jhrs. Trans. and commentary by Jörg M. Meier. Bonn.

[2] Meier, Jörg M., 1990a, “Kommentar zum Text,” in *Das Büchlein der Venus*, Bonn p. 49.

[3] Meier, Jörg M., 1990b, “Text und Überstzung,” in *Das Büchlein der Venus*, Bonn p. 23.

[4] Grammatically, these words should read LIBELLUS VENERI NIGRÆ SACER rather than NIGRO, yet it appears this way in the four main versions examined by Meier (1990b p. 22), perhaps as a play on *nigromancy*.

[5] Pertaining to the underworld and/or River Styx; also, a pun on *stiga*, witch.

[6] Inhabitant, with the sense of “resident alien.”

[7] *Tuba* refers most directly to the straight bronze war-trumpet of the ancient Romans, yet the graphic shows the horn as curved, like a shofar. See further discussion in article. *Tuba* certainly also puns upon the tuba-tree in the Koran, the tallest and most beautiful tree in Paradise viewed by Idris/Enoch. In Sufi poetry the tuba-tree, or tree of life, is often where the soul alights like a Phoenix.

[8] We use *daemon* rather than *demon* throughout to evoke both the meaning “evil spirit” associated with “demon,” and the older meaning, from Greek δαίμων, of a supernatural being, spirit, or “genius” whose nature is between that of gods and men. Using “æ” as a false archaism was done often in the literature of the era to suggest older meaning (as Spenser does in titling his poem the *Færie Queene*.)

[9] “You” may be read as a direct address of Venus, the reader, or both.

[10] *Vocatus*: invocations, (ceremonial) calls or conjurings.

[11] *Siggilum*: often written as “sigil” in other magical / astrological texts, but translated here as “Seal” to match Dee’s English usage.

[12] While this might be translated as “black art” or even “alchemy,” we used a term more contemporaneous with Dee to draw on the connotations of his time rather than ours. Notably, one of the later manuscripts examined by Meier use the Latin *necromantice* instead of *negromantice* (see 1990b p 22, 30).

[13] Using the Greek numbering system. In most modern Biblical translations, this Psalm—praising the restoration of Jerusalem—is Psalm 147.

[14] According to Meier 1990a, in the Warburg manuscript, the lines are red and the other designs are green, on a light green background. In the Munich manuscript the left seal is black on reddish brown and the right black on green, showing a scribe not aware that that this was supposed to be the front and back of the same seal.

[15] *Cornu*. Note Dee uses *cornu* for this type of horn and *tuba* for the other, although a *cornus* could also be a curved musical horn.

[16] According to Meier 1990a, in the Warburg manuscript the names of the Archangels, Evangelists, and the twelve crosses in the outer circle are in the same brown as the text, while all other names and crosses are red. In the Munich manuscript, the outer ring of the circle is red, the middle ring black, and the inner ring green.

[17] *Libellus Veneri nigræ Sacer*: compare to title and note 4.

